



This is a digital copy of a book that was preserved for generations on library shelves before it was carefully scanned by Google as part of a project to make the world's books discoverable online.

It has survived long enough for the copyright to expire and the book to enter the public domain. A public domain book is one that was never subject to copyright or whose legal copyright term has expired. Whether a book is in the public domain may vary country to country. Public domain books are our gateways to the past, representing a wealth of history, culture and knowledge that's often difficult to discover.

Marks, notations and other marginalia present in the original volume will appear in this file - a reminder of this book's long journey from the publisher to a library and finally to you.

Usage guidelines

Google is proud to partner with libraries to digitize public domain materials and make them widely accessible. Public domain books belong to the public and we are merely their custodians. Nevertheless, this work is expensive, so in order to keep providing this resource, we have taken steps to prevent abuse by commercial parties, including placing technical restrictions on automated querying.

We also ask that you:

- + *Make non-commercial use of the files* We designed Google Book Search for use by individuals, and we request that you use these files for personal, non-commercial purposes.
- + *Refrain from automated querying* Do not send automated queries of any sort to Google's system: If you are conducting research on machine translation, optical character recognition or other areas where access to a large amount of text is helpful, please contact us. We encourage the use of public domain materials for these purposes and may be able to help.
- + *Maintain attribution* The Google "watermark" you see on each file is essential for informing people about this project and helping them find additional materials through Google Book Search. Please do not remove it.
- + *Keep it legal* Whatever your use, remember that you are responsible for ensuring that what you are doing is legal. Do not assume that just because we believe a book is in the public domain for users in the United States, that the work is also in the public domain for users in other countries. Whether a book is still in copyright varies from country to country, and we can't offer guidance on whether any specific use of any specific book is allowed. Please do not assume that a book's appearance in Google Book Search means it can be used in any manner anywhere in the world. Copyright infringement liability can be quite severe.

About Google Book Search

Google's mission is to organize the world's information and to make it universally accessible and useful. Google Book Search helps readers discover the world's books while helping authors and publishers reach new audiences. You can search through the full text of this book on the web at <http://books.google.com/>

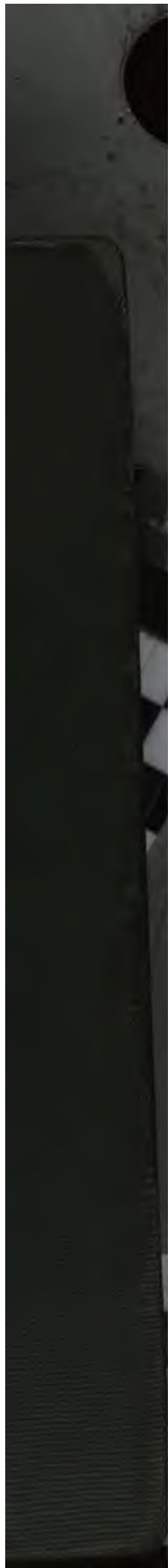







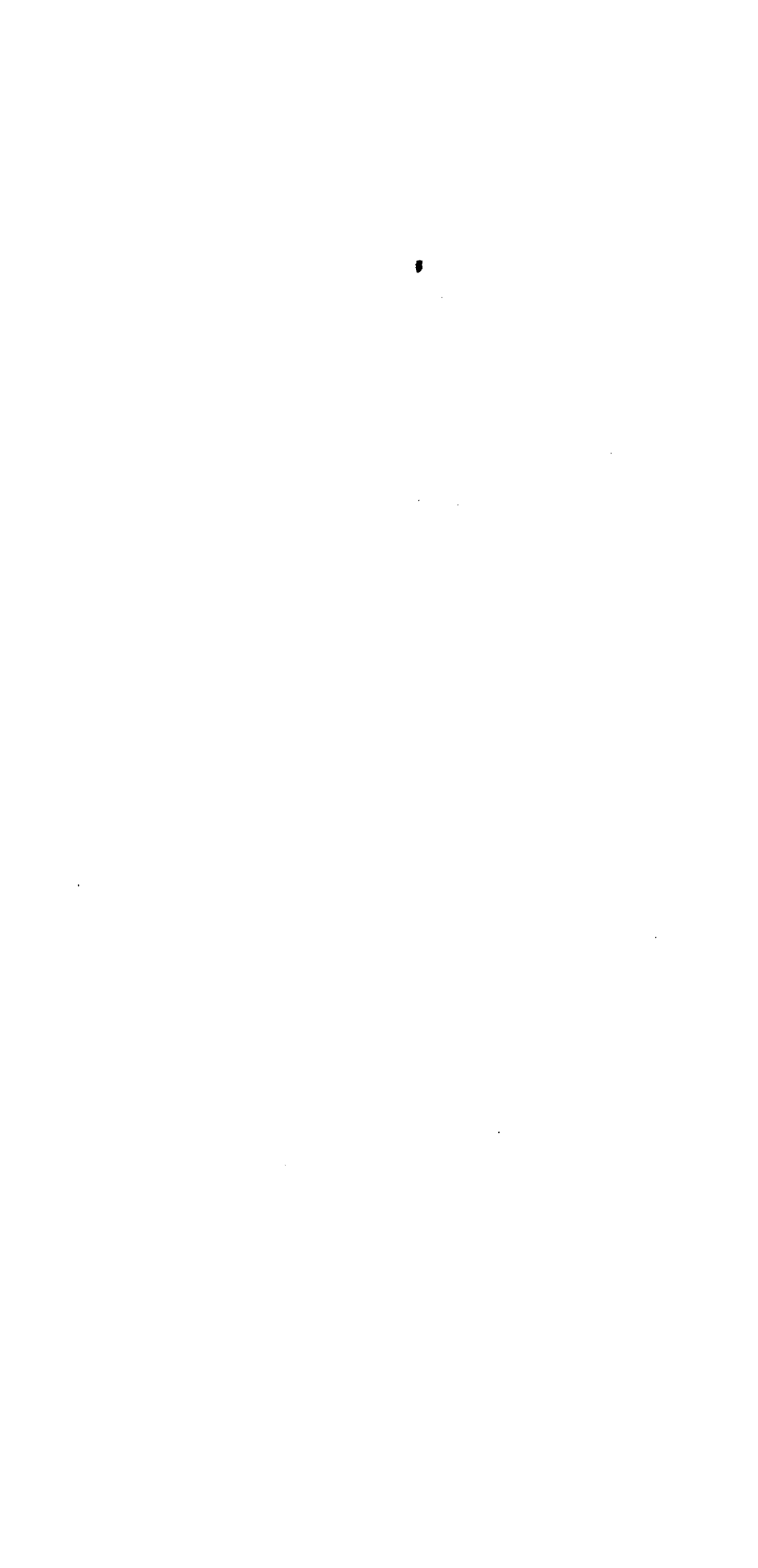

8
ir
um
clo

THREAD-CUTTING METHODS

I

THREAD-CUTTING METHODS

A TREATISE ON THE OPERATION AND USE OF
VARIOUS TOOLS AND MACHINES FOR FORMING
SCREW THREADS, INCLUDING THE APPLICA-
TION OF LATHES, TAPS, DIES, STANDARD AND
SPECIAL ATTACHMENTS, THREAD - MILLING
MACHINES, AND THREAD-ROLLING MACHINES

BY

FRANKLIN D. JONES

ASSOCIATE EDITOR OF MACHINERY

AUTHOR OF "TURNING AND BORING," "PLANING AND MILLING,"
"MECHANISMS AND MECHANICAL MOVEMENTS," ETC.

FIRST EDITION

NEW YORK

THE INDUSTRIAL PRESS

LONDON: THE MACHINERY PUBLISHING CO., LTD.

1918

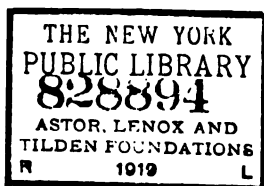

COPYRIGHT. 1918.
BY
THE INDUSTRIAL PRESS
NEW YORK

COMPOSITION AND ELECTROTYPING BY F. H. GILSON COMPANY, BOSTON, U. S. A.

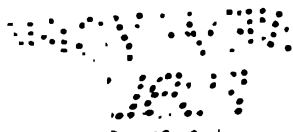

PREFACE

THE universal use of the screw thread, either as a fastening device or for transmitting motion from one part of a machine to another, combined with the numerous conditions under which it is used, has led to the development of many different kinds of tools and machines for forming screw threads. These tools vary from the hand-operated tap or die to the specialized semi-automatic and fully automatic machines capable of threading duplicate parts with considerable rapidity. While much has been published on thread-cutting practice, most of this material has been of a miscellaneous character, and there is evidently need for a general treatise covering the various machines and auxiliary equipment used for this important branch of machine shop work.

The purpose of this treatise is not only to describe all the important types of tools, machines, and methods which have been developed for producing external and internal screw threads, but to show the relation between the different processes. If the screw thread problem were merely to determine *how* to cut a thread of the required size, pitch, and accuracy, it would, in most cases, be relatively simple, but like other manufacturing problems, it is usually complicated by the fact that the work must be done on a commercial basis. The various methods of forming screw threads are familiar to practically all machinists and machine shop foremen, but comparatively few know to what general class of work each method is best adapted. While it is often difficult to decide this question, an understanding of the reasons why different types of threading tools and machines were originated and the kind of work for which they are generally used will at least simplify the problem greatly. A special effort has been made to include in this book all the information

possible pertaining either to the adaptability of various types of tools and machines or to their relative merits as applied to different classes of work.

This treatise deals with different standard forms of screw threads; general thread-cutting practice in engine lathes or other machines using a single-point tool; the special auxiliary thread-cutting mechanisms and attachments applied to engine lathes or other machines; the design, operation, and application of various classes of threading dies and taps; standard and special threading machines; tapping machines and attachments; the causes of defective and inaccurate screw threads; thread milling machines and their use; and the production of screw threads by the rolling process. It was neither possible nor desirable to illustrate and describe every different design of machine or tool used in connection with external and internal thread-cutting operations, although many variations in design have been featured whenever there seemed to be a good reason for so doing.

The assistance of manufacturers of thread-cutting equipment in supplying drawings, photographs, and information is much appreciated, as this coöperation has made it possible to prepare a more comprehensive treatise and one of greater value to those interested in this general subject.

F. D. J.

NEW YORK, *July*, 1918.

CONTENTS

CHAPTER I

THREAD-FORMING PROCESSES AND CLASSES OF SCREW THREADS

	PAGES
General Methods of Forming Screw Threads — Different Forms of Threads and their Important Features	1-13

CHAPTER II

GENERAL THREAD-CUTTING PRACTICE IN LATHE

Application of Engine Lathe for Screw Cutting — Use of Automatic Threading Lathe	14-43
--	-------

CHAPTER III

THREAD-CUTTING ATTACHMENTS

Attachments for Cutting Screws of Large Lead or Special Pitch — Thread-chasing Attachments of Turret Lathes	44-70
---	-------

CHAPTER IV

THREAD-CUTTING DIES AND THEIR APPLICATION

Types of Non-opening and Self-opening or Automatic Dies — Cutting Speeds for Threading Dies	71-117
---	--------

CHAPTER V

CHASERS FOR THREAD-CUTTING DIES AND CHASER GRINDING

Hobbed and Milled Chasers — Angle of Chaser Throat and Effect on Action of Die — Steel for Die Chasers	118-134
--	---------

CHAPTER VI

DIFFERENT CLASSES OF TAPS AND CAUSES OF ERRORS IN TAPPED HOLES

Different Designs of Solid and Collapsing Taps — Diameter of Hole before Tapping — Speeds for Tapping	135-164
---	---------

CHAPTER VII

DIE- AND TAP-HOLDERS AND REVERSING CHUCKS

	PAGES
Floating, Releasing, and Non-releasing Die-holders — Frictional and Reversing Tapping Chucks	185-186

CHAPTER VIII

TAPPING MACHINES

Tapping Machines of Horizontal and Vertical Designs — Nut Tappers of Semi-automatic and Fully Automatic Types	187-213
--	---------

CHAPTER IX

STANDARD AND SPECIAL THREADING MACHINES

Bolt Cutters — Vertical Threading Machines — Stud- threading Machines equipped with Magazine Feed	214-226
--	---------

CHAPTER X

THREAD MILLING

Milling Threads with Single and Multiple Cutters — Classes of Work for Thread Milling Machines	227-245
---	---------

CHAPTER XI

THREAD MILLING MACHINES AND ATTACHMENTS

Various Designs of Thread Milling Machines — Hobbing Method of Thread Milling	246-278
--	---------

CHAPTER XII

THREAD ROLLING

Types of Thread-rolling Machines — Advantages and Range of Thread-rolling Process	279-321
--	---------

CHAPTER XIII

CUTTING AND GRINDING PRECISION SCREW THREADS

Compensating for Errors — Thread Grinding — Making Precision Screws for Scientific Instruments	322-337
---	---------

THREAD-CUTTING METHODS

CHAPTER I

THREAD-FORMING PROCESSES AND CLASSES OF SCREW THREADS

THE formation of accurate and interchangeable screw threads on a commercial or manufacturing basis has been a difficult proposition in many machine shops. The extent of the difficulties encountered in connection with this work may depend largely upon the meaning of that indefinite term "accurate" and also upon the length of time that is allowed for the screw-cutting operation. On many classes of threading work the degree of accuracy, combined with the speed of production demanded, makes screw cutting a troublesome operation, and even when the conditions are not unusually severe, the production of smooth, correctly formed threads requires tools that are properly made and applied. While some equipment is incapable of producing good screw threads, regardless of the time that might be expended (either because it was poorly constructed to begin with or is in bad condition), many notable improvements have been made in screw-thread forming tools and methods, and in this general review of the subject the more important types of tools or machines for producing screw threads will be described. In this book, those features that have a direct bearing on the accuracy of screw threads and the speed of production will be considered, as well as the relative merits of different types of tools or machines and the general classes of work for which they are adapted.

General Methods of Forming Screw Threads.—The two general methods of forming screw threads may be defined as the

cutting method and the rolling or displacement method. Some of the various modifications of these two general methods will be outlined. The cutting methods as applied to external threads are briefly as follows:

1. By taking a number of successive cuts with a single-point tool that is traversed along the part to be threaded at a rate per revolution of the work depending upon the lead of the thread. (Common method of cutting screw threads in the engine lathe.)

2. By taking successive cuts with a multiple-point tool or chaser of the type used to some extent in conjunction with the engine lathe and on lathes of the Fox or monitor types.

3. By using a tool of the die class, which usually has four or more multiple-point cutting edges or chasers and generally finishes the thread in one cut or passage of the tool.

4. By a single rotating milling cutter, which forms the thread groove as either the cutter or the work is traversed axially at a rate depending upon the thread lead.

5. By a multiple rotating milling cutter which completes a thread in approximately one revolution of the work.

When screw threads are produced by the rolling or displacement method, there are two general processes:

1. By rolling the blank in contact with a revoluble disk or roll, the periphery of which has either a single thread or a multiple thread corresponding in pitch to the thread required.

2. By rolling the blank in contact with flat dies having parallel ridges which are spaced in accordance with the required pitch and which form the screw thread.

Internal screw threads, or those in holes, may or may not be produced by the same general method that is applied to external work. There are three commercial methods of importance, namely:

1. By the use of a single-point traversing tool in the engine lathe or a multiple-point chaser in some cases.

2. By means of a tap which, in machine tapping, usually finishes the thread in one cut or passage of the tool.

3. By a rotating milling cutter of either the single or the multiple type.

Controlling Motion of Thread-forming Tool. — The general methods of controlling the motion of a thread-forming tool relative to the work, for generating thread grooves of helical or "spiral" form, vary according to the type of tool or machine used for the screw-cutting operation. Considering, first, the action of the tool while cutting a thread groove, there are three general methods of securing the necessary motion:

1. The tool-holder or carriage (or the work in some cases) is traversed by a lead-screw driven by gearing of such a ratio that the relative motion of the tool per revolution of the work is equal to the lead of the screw thread required.

2. The motion is obtained by the direct action of a lead-screw, which is not driven through gearing and has a lead equal to that required on the part to be threaded.

3. The tool when in the form of a tap or die may be self-propelling or self-leading, the tool moving each revolution a distance equal to the thread lead as the result of its screwing action, caused by the location of the cutting teeth along a helical path.

After a thread-cutting tool has completed a cut, it is usually necessary to return it to the starting point either for the purpose of taking another cut (as when using a single-point tool) or for removing the tool from the work (as when withdrawing a tap or die from the threaded part). This return movement may be obtained by the following methods:

1. By a hand or power traversing movement of the tool carriage or holder in the direction of the axis of the work, after withdrawing the cutting tool or tools for clearing the screw thread.

2. By reversing the rotation of the work- or tool-spindle for backing a non-collapsing tap out of a hole or for unscrewing a non-opening die from the threaded part.

3. By running a tap or die at a slower speed than the work while cutting the thread and then at a faster speed for unscrewing the thread-cutting tool.

When a thread is being formed by the rolling process, the tool, if of circular shape, simply moves at right angles to the axis of the work for bringing the roll into contact with the part to be

threaded and for removing it after the thread has been formed. In the case of flat thread-rolling dies, the blank to be threaded is rolled between a stationary die and a movable die having a reciprocating motion.

Selection of Thread-forming Method. — One of the most important questions relating to the formation of screw threads is the particular method that should be employed for a certain class of work. What is the most rapid method of performing the screw-cutting operation without sacrificing the necessary accuracy? That is the question that has often puzzled shop foremen and superintendents and one that is not answered in the same way by those who have studied the problem of screw thread production. Variations of practice in different shops are often due to the fact that the equipment at hand is used not because it is considered the best, but because there is no choice. In other words, the amount of money appropriated for new tools is often the real reason why different types of tools are used for the same general classes of work. While each class or type of threading-forming tool or machine has a definite field, in some cases these fields overlap, and then judgment, experience and records of past performance must be utilized in deciding what method is to be employed.

Among the important factors that affect the thread-forming methods may be mentioned the diameter of the screw, pitch of thread, degree of accuracy necessary, number of parts to be threaded, location of thread, material of which parts are made, and the relation of threading operation to other work which may precede or follow it. No inflexible rule can be given as a guide, and the different factors mentioned may be combined in various ways, thus changing the problem partly or entirely. Other conditions peculiar to any one job may also have a decided effect on the exact method of procedure. This matter of selecting equipment for the production of screw threads involves not only a study of the different classes of work for which various types of tools are adapted, but a careful investigation into the performance of different makes of tools of the same class or type. The difference in the quality of tools of the same class accounts

for many variations of opinion. One man contends that a certain type of tap or die is incapable of accurate work, but, if the truth were known, the general type may be entirely satisfactory when properly made or applied. This is also true of thread-forming tools of other classes. In dealing with the various types of thread-forming equipment, the kind of work and the particular advantages of each type will be enumerated in as specific a manner as seems practicable. Unfortunately, however, it is not possible to deal with this question of selecting thread-forming tools in such a definite way that instructions may be followed to the letter and without the assistance of experience and judgment.

Screw Thread Definitions. — In order to avoid any misunderstanding or confusion regarding the terms that may be used throughout this treatise, some definitions relating to different parts or elements of screw threads will be given.

Pitch. — The distance from the center (or top) of one thread to the center of the next thread, measured parallel to the axis of the screw. This definition applies whether the screw has a single thread or is of the multiple-threaded form. The word "pitch" is frequently used to denote the number of threads per inch. For example, the expression "six-pitch screw" is used to indicate that the screw has six threads per inch. This usage of the word pitch is sometimes confusing and is not recommended.

Lead. — The distance that a thread advances in a single turn, or the distance that a nut would advance in an axial direction if turned one complete revolution. The lead and pitch of a single screw thread are equal; the lead of a double thread is twice the pitch; the lead of a triple thread is three times the pitch, and so on.

Pitch Diameter. — The pitch diameter, which is also known as the "angle diameter" and as the "effective diameter," is equivalent to the outside diameter minus the depth of one thread. The pitch diameter of a screw having a single thread with angular sides is the distance between the points at which a line passing at right angles through the axis of the screw intersects the sides or slopes of the thread.

Root Diameter. — The minimum diameter of a screw or the diameter across the bottom or root of the thread, measured at right angles to the axis of the screw. The root diameter is also known as the “core diameter.”

Root of Thread. — The root is the bottom of the groove which forms a thread, whether the thread is external or internal.

Crest of Thread. — The name applied to the curved or rounded top of a Whitworth thread.

Slope of Thread. — The straight part or side of a thread.

Angle of Thread. — The angle between the sides or slopes measured in a plane intersecting the axis of the screw.

Form of Thread. — The shape or contour of the outline of the thread in a plane intersecting the axis of the screw.

Multiple Thread. — A screw thread that is formed of two or more single threads. For instance, a double thread is a multiple form having two separate or single threads starting diametrically opposite or at points 180 degrees apart; a triple thread has three single threads starting at points 120 degrees apart; and a quadruple thread has four single threads starting at points 90 degrees apart. A multiple thread is used to increase the lead of a screw without weakening it by cutting a coarse single thread.

Standard Screw Thread. — A thread which conforms to an adopted standard in regard to the form or contour of the thread itself, and as to the pitch or number of threads per inch for a given screw diameter.

Special Screw Thread. — A screw thread having either a modified form or a pitch which is either greater or less for a given screw diameter than the adopted standard.

Different Forms of Screw Threads. — A number of different thread forms are shown in the accompanying illustrations which include the names and proportions of the threads. Different forms have been originated and adopted at various times, either because they were considered superior to other existing forms or because of the special requirements of screws used on a certain class of work. Some of the more important and desirable features of a screw thread are as follows: 1. The thread should

CLASSES OF SCREW THREADS

United States Standard Thread

Number of Threads per Inch Corresponding to a Given Diameter							
Diameter	Threads per Inch	Diameter	Threads per Inch	Diameter	Threads per Inch	Diameter	Threads per Inch
1/16	64	1 1/16	10	1 3/4	5	3 3/8	3 1/4
3/32	50	3/8	9	1 7/8	5	3 1/2	3 1/4
1/8	40	1 1/8	9	1 7/8	5	3 5/8	3 1/4
5/32	36	1	8	1 9/16	5	3 3/4	3
3/16	32	1 1/4	7	2	4 1/2	3 3/4	3
7/32	28	1 1/2	7	2 1/8	4 1/2	4	3
1/4	20	1 3/8	7	2 1/4	4 1/2	4 1/4	2 3/4
5/16	18	1 1/2	7	2 3/8	4	4 1/4	2 3/4
3/8	16	1 5/8	6	2 1/2	4	4 3/4	2 3/4
7/16	14	1 3/4	6	2 5/8	4	5	2 1/2
1/2	13	1 7/8	6	2 3/4	4	5 1/4	2 1/2
5/8	12	1 3/4	6	2 7/8	3 1/2	5 1/2	2 3/8
3/4	11	1 9/8	5 1/2	3	3 1/2	5 3/4	2 3/8
7/8	11	1 3/4	5 1/4	3 1/4	3 1/2	6	2 1/4
1 1/8	10	1 1/2	5 1/4	3 1/2	3 1/2

Depth of Thread and Width of Flat					
Threads per Inch	Depth of Thread	Width of Flat	Threads per Inch	Depth of Thread	Width of Flat
2 1/4	0.2887	0.0556	18	0.0361	0.0069
2 3/8	0.2735	0.0526	20	0.0325	0.0062
2 1/2	0.2598	0.0500	22	0.0295	0.0057
2 5/8	0.2474	0.0476	24	0.0271	0.0052
2 3/4	0.2362	0.0455	26	0.0250	0.0048
2 7/8	0.2259	0.0435	28	0.0232	0.0045
3	0.2165	0.0417	30	0.0217	0.0042
3 1/4	0.1998	0.0385	32	0.0203	0.0039
3 1/2	0.1856	0.0357	34	0.0191	0.0037
4	0.1624	0.0312	36	0.0180	0.0035
4 1/4	0.1443	0.0278	38	0.0171	0.0033
5	0.1299	0.0250	40	0.0162	0.0031
5 1/4	0.1181	0.0227	42	0.0155	0.0030
6	0.1083	0.0208	44	0.0148	0.0028
7	0.0928	0.0179	46	0.0141	0.0027
8	0.0812	0.0156	48	0.0135	0.0026
9	0.0722	0.0139	50	0.0130	0.0025
10	0.0650	0.0125	52	0.0125	0.0024
11	0.0590	0.0114	56	0.0116	0.0022
12	0.0541	0.0104	60	0.0108	0.0021
13	0.0500	0.0096	64	0.0101	0.0020
14	0.0464	0.0089	68	0.0096	0.0018
15	0.0433	0.0083	72	0.0090	0.0017
16	0.0406	0.0078	80	0.0081	0.0016

be of such a shape that the tool for producing it can be easily made. 2. The cutting edges of the tool should not be so pointed or delicate that they are easily worn away by the cutting action. 3. It should be possible to test the diameter and form of the thread with a minimum of measuring and gaging. 4. The form should be such that a good bearing between a screw and nut may be obtained without unnecessary care and refinement in cutting and measuring. 5. The angles of the sides should be as acute as is consistent with the required strength, because the greater the angle, the greater the friction between the threads of a bolt and nut and also the greater the force tending to burst the nut.

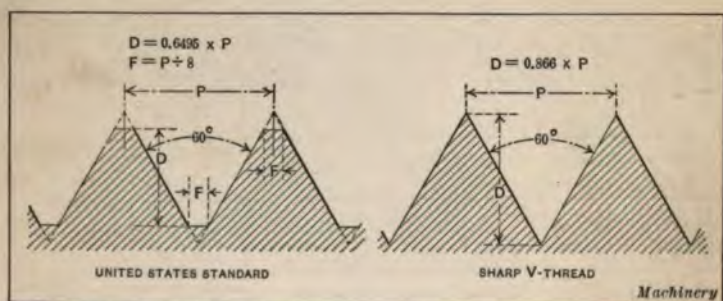

Fig. 1. The United States Standard Thread and the Sharp V-thread

United States Standard Thread. — This form of thread is commonly used in the United States; it is also known as the "Sellers thread," as it was originated by William Sellers. The accompanying table gives the numbers of threads per inch for outside diameters ranging from $\frac{1}{16}$ inch up to 6 inches, inclusive. The U. S. standard form has largely replaced the sharp V-thread, because of its superiority. As the U. S. standard has a flat top (see Fig. 1), it is not so easily injured as a sharp V-thread, and taps and dies wear less at the points of the teeth and retain their size longer. Screws having U. S. standard threads are from one-eighth to one-fourth stronger to resist tension than screws with V-threads, because, for a given outside diameter, there is a larger root diameter or effective area. For instance, a U. S. standard screw thread of 1 inch outside diameter and

eight threads per inch has a root diameter of 0.8376 inch, whereas a screw of corresponding outside diameter and pitch, but with a sharp V-thread, has a root diameter of 0.7835 inch. The relative strength varies according to the size of the screw, the smaller U. S. standard screws being approximately one-fourth stronger than those having V-threads, whereas the larger sizes are only about one-eighth stronger in tension.

Sharp V-thread. — The top and bottom or root of this thread form are theoretically sharp (see Fig. 1), but in actual practice the thread is made with a slight flat, owing to the difficulty of producing a perfectly sharp edge and because of the tendency

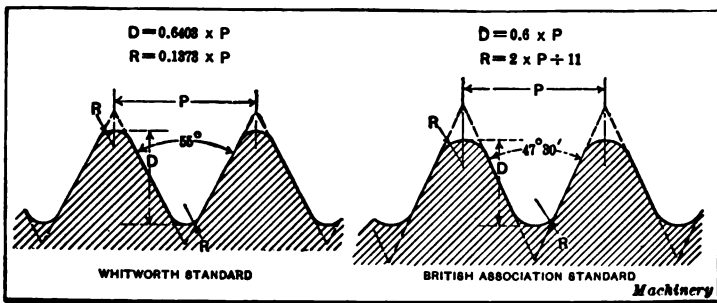

Fig. 2. The Whitworth or British Standard, which is used Principally in Great Britain, and the British Association Standard

of such an edge to wear away or become battered. This flat is usually equal to about one twenty-fifth of the pitch, although there is no generally recognized standard. Owing to the difficulties connected with the V-thread, the tap manufacturers agreed in 1909 to discontinue the making of sharp V-thread taps, except when ordered. One advantage of the V-thread is that the same cutting tool may be used for all pitches, whereas, with the U. S. standard form, the width of the point or the flat varies according to the pitch. This is one of the reasons why a great many V-threads are still in use. The V-thread is also regarded as a good form where a steam-tight joint is necessary, and many of the taps used on locomotive work have this form of thread.

Whitworth Standard Thread.—The Whitworth or British standard thread is used principally in Great Britain. This thread is not as easily produced as the U. S. standard form, although it has some advantages, especially on screws subjected to heavy service. As the Whitworth thread is rounded at the root and crest (see Fig. 2), there are no sharp edges or corners from which fractures may start. Screws and nuts having this form of thread will also work well together after continued heavy service. In the United States, Whitworth threads have been used on special screws and on a great many staybolts for the fire-boxes of locomotive boilers. A series of tests have indicated that the Whitworth thread is somewhat stronger than the U. S. standard form.

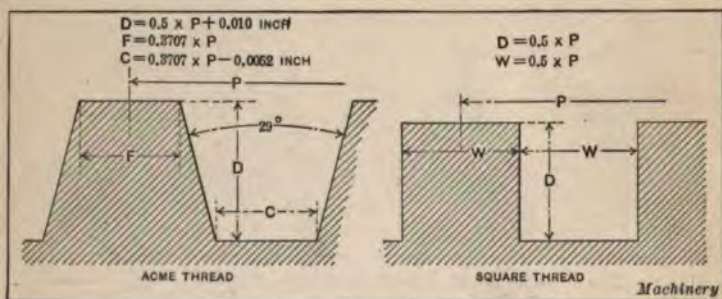

Fig. 3. The Acme Standard Thread and the Square Thread

British Association Standard Thread.—This form of thread is similar to the Whitworth thread in that the root and crest are rounded (see Fig. 2). The angle, however, is only 47 degrees 30 minutes and the radius of the root and crest are proportionately larger. This thread is used in Great Britain and, to some extent, in other European countries for very small screws. Its use in the United States is practically confined to the manufacture of tools for export. This thread system was originated in Switzerland as a standard for watch and clock screws, and it is sometimes referred to as the "Swiss small screw thread standard."

Acme Thread.—The Acme thread (see Fig. 3) is extensively used at the present time in preference to the square thread,

especially for lead-screws and similar parts. The Acme form is stronger than the square thread, and it may easily be cut with a die, which is not the case with a square thread. When an Acme thread is engaged by a sectional nut like the half-nut of a lathe apron, engagement or disengagement is more readily effected than with a square thread; an adjustable split nut may also be used in connection with an Acme screw thread to compensate for wear and to eliminate back-lash or lost motion. The depth of an Acme thread is made equal to one-half the pitch plus 0.010 inch to provide clearance between the top of the screw thread and the bottom of the thread groove in the nut. The included angle between the sides of the thread is 29 degrees.

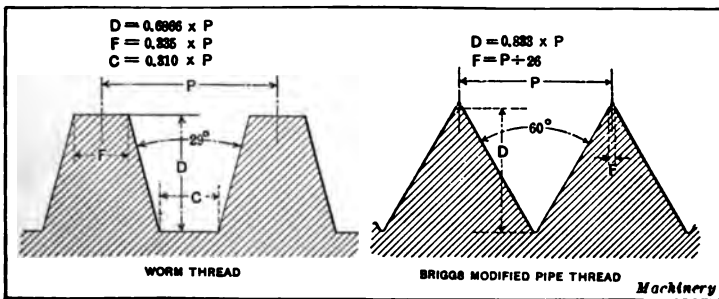

Fig. 4. Standard Worm Thread and the Modified Form of Briggs Standard Pipe Thread

Square Thread.—The square thread is so named because the section is square (see Fig. 3), the depth, in the case of a screw, being equal to the width or one-half the pitch. The thread groove in a square-threaded nut is made a little greater than one-half the pitch in order to provide a slight clearance for the screw; hence, the tools used for threading square-threaded taps are a little less in width at the point than one-half the pitch. The pitch of a square thread is usually twice the pitch of a U. S. standard thread of corresponding diameter.

Worm Thread.—This form of thread (see Fig. 4) has the same angle as the Acme thread (29 degrees), but the depth is greater and the widths of the flats at the top and bottom are less. The worms of worm gearing have this form of thread.

Briggs Standard Pipe Thread.— The original Briggs standard pipe thread had a round crest and root, but this form was difficult to produce and it has been modified as shown in Fig. 4, the root being sharp and the top flat. The taps used in connection with this standard have a taper of $\frac{3}{4}$ inch per foot on the diameter. The tool used for cutting this thread on a tap or on a plug that is to be inserted in a tapped hole should be set at right angles to the axis of the work, instead of locating it square with the tapering surface.

French and International Standard.— This form of thread is practically the same as the U. S. standard, although a clearance space is ordinarily provided at the root by increasing the depth.

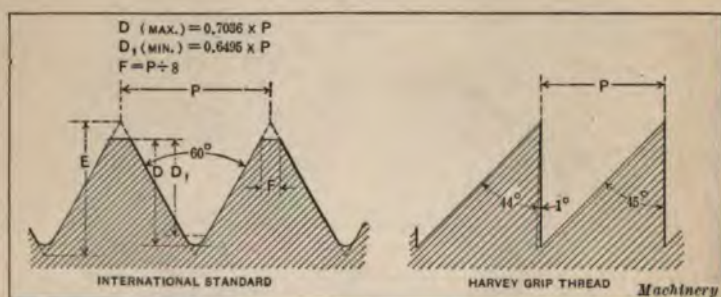

Fig. 5. The French and International System Standard Thread and the Harvey Grip Thread

The shape of this clearance is left to the manufacturer, but it is not to exceed one-sixteenth of the height E of the original triangle (see Fig. 5). The International Congress which adopted this standard at Zürich, in 1898, recommended a rounded profile at the root as shown in the illustration.

Harvey Grip Thread.— The characteristic feature of this thread is that one side inclines 44 degrees from a line at right angles to the axis, whereas the other side has an inclination of only 1 degree, as shown in Fig. 5. This form of thread is sometimes used when there is considerable resistance or pressure in an axial direction and when it is desirable to reduce the radial or bursting pressure on the nut as much as possible.

Trapezoidal or Buttress Thread. — This form of thread differs from the Harvey grip thread in that the side intended to receive the thrust is perpendicular to the axis of the screw instead of being inclined 1 degree (see Fig. 6), and the top and root are flat. The pitch of a trapezoidal thread is equal to twice the outside diameter divided by the constant 15.

Löwenherz Thread. — The Löwenherz thread (see Fig. 6) is intended for the fine screws of instruments and is based on the metric system. It has been adopted by the Bureau of Standards as there has been a lack of uniformity in the screws applied to American-made instruments.

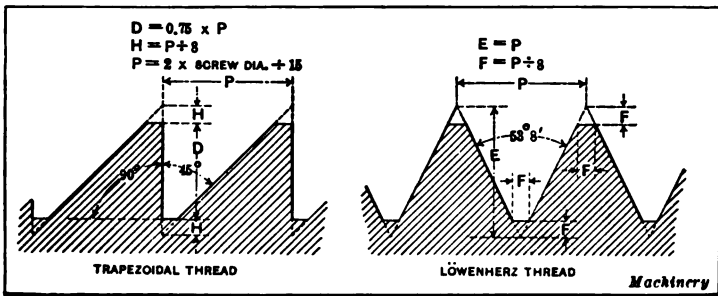

Fig. 6. The Trapezoidal or Buttress Thread and the Löwenherz Thread

Cadillac Screw Thread. — This form of thread is a cross between the U. S. standard and the sharp V-thread, the top of the thread being flat and the root sharp. The included angle is 60 degrees.

S. A. E. Standard. — The Society of Automotive Engineers screw standard (sometimes referred to as the A. L. A. M. standard) is the same as the U. S. standard, but the number of threads per inch for a given diameter is greater. This standard was adopted because the pitches of the U. S. standard threads are too coarse for some classes of automobile work, especially when the threaded part is subjected to constant vibration. In addition to the original standard, there is a special standard for diameters larger than 1½ inch which includes a coarse system and a fine system of pitches.

CHAPTER II

GENERAL THREAD-CUTTING PRACTICE IN LATHE

THE engine lathe is indispensable for many screw-cutting operations, partly because it is adapted to a wide range of pitches and diameters. The swing of the lathe either over the bed or carriage equals, approximately, the maximum diameter of external screw thread that can be cut, and the number of pitches varies according to the change-gear mechanism, but is usually large enough for all ordinary requirements. There is also an advantage in most instances in being able to cut threads on the same machine that is used for the turning operation, because the thread is then cut concentric with other finished surfaces. A well-constructed lathe is also capable of very accurate thread cutting.

Conditions Governing Use of Lathe for Screw Cutting. — The conditions under which the lathe is commonly used for cutting screw threads are as follows:

1. When a part has been turned and one or more screw threads must be cut to complete it.
2. When the screw thread is not standard or is so large in diameter that the use of a tap or die is not practicable.
3. When there is not enough thread cutting to warrant the use of machines or equipment designed primarily for screw cutting.
4. When the lathe is the only means available, in which case it is sometimes applied to screw-cutting operations which could be done more efficiently in some other way.
5. When the lathe is the only machine available that will cut threads of the required standard of accuracy.

The engine lathe equipped with a single-point tool is almost invariably used for cutting screw threads on parts that are

turned in it, but it is seldom used for threading operations on parts that have been previously turned in another type of machine; in fact, when threading operations are preceded by turning operations, the former are, as a rule, performed in the machine that did the turning, whether it is an engine lathe or some other form of lathe or turning machine. For instance, in the turret lathe and automatic screw machine practice, dies are used for most external thread-cutting operations and taps for internal work. The object of cutting the screw threads in the same machine is to avoid a second operation on another machine, and, at the same time, to secure accuracy by cutting the threads before the position of the work has been disturbed. If, for example, a piston-rod has been turned in the engine lathe and a screw thread is required at the piston end for receiving a nut, the lathe would, of course, be used for cutting that thread. On the other hand, when cutting a screw thread is the principal operation, the engine lathe may either have competitors or be out of the race entirely. If the part is simply a screw and the only operation is that of cutting the screw thread, a special threading machine of the die class or a thread milling machine might be used in preference to the lathe. If a thread-milling machine or die type of thread-cutting machine were not at hand, the lathe would generally be used, unless the number of parts to be threaded were large enough to warrant installing a machine designed especially for screw cutting.

Position of Tool and Traversing Movement. — The cutting end of a single-point thread tool is shaped to correspond to the cross-sectional shape of the thread groove in a plane intersecting the axis of the screw. The tool should be so located with reference to the part to be threaded that the angle of the thread cut by the tool will be the same as the tool angle and so that the sides of the thread will incline equally with reference to the axis of the screw. To secure the correct thread angle (assuming that the tool is properly ground), the upper face must lie in a plane coinciding with the axis of the screw; in other words, if the upper face were flat and horizontal, it should be at the same height as the lathe centers. A common method of setting a tool so

that each side will have the same inclination is by using the gage intended for testing the tool when grinding it. This gage (one form of which is shown at *A*, Fig. 6) is simply placed against the turned surface to be threaded, in case the thread is straight or cylindrical, and the tool is adjusted until the cutting point fits accurately into the V-shaped notch in the gage.

Special gages are sometimes used for setting threading tools, especially when making thread gages of the plug form or cutting other precision screw threads. The tool setting gage may be in the form of a cylindrical plug which is accurately centered and has a 60-degree groove cut into it, assuming that the gage is intended for U. S. standard thread tools. When a tool is to be set, the gage is simply placed between the centers of the lathe and the tool is adjusted until the cutting end accurately coincides with the groove of the gage. The latter may also be provided with means for setting the tool at the correct height or so that the top surface lies in a plane intersecting the axis of the work. A simple arrangement for testing the vertical position of the tool consists of a small plug which is inserted in a hole extending crosswise through the body of the gage. This hole is so located that one side is exactly in line with the axis or center-line of the gage. The plug projects far enough so that its lower side can be used for setting the tool, which is done by simply adjusting the tool until the upper face bears evenly on the lower side of the plug.

Some gages of this general type consist of a centered arbor upon which is mounted two close-fitting sleeves. The inner end of each sleeve is beveled to an angle of 30 degrees, so that, as the sleeves are placed in contact, they form a 60-degree groove. The opposite end of each bushing may also be ground to form a 55-degree groove for Whitworth thread tools. In setting a tool, these bushings are pushed up against the cutting end, and a piece of white paper is held beneath the line of contact, so that any error in adjustment may easily be observed. The center line of the tool or a line bisecting the cutting end should be at right angles to the axis of the screw, regardless of whether the screw is straight or tapering, although this practice is varied

in the case of a Whitworth thread. This point will be considered later.

In order to form a complete thread with a single-point tool, a number of cuts are required, the number depending upon the pitch of the thread and the corresponding depth of the thread groove. On all standard engine lathes, a gear-driven lead-screw is used to traverse the tool a distance equal to the lead of the thread for each revolution of the part being threaded. Gearing of the correct ratio may be placed in position each time a screw thread of different lead or pitch is to be cut, or the gearing may form an integral part of the machine, and be so arranged

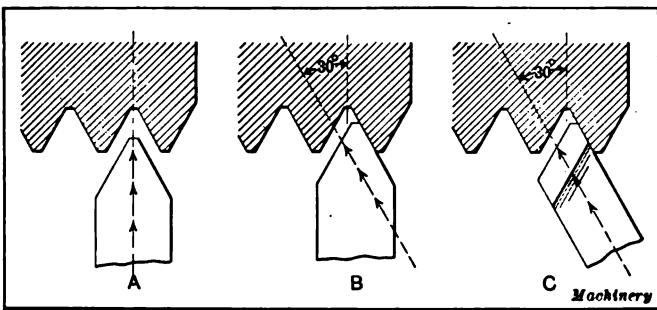

Fig. 1. Straight and Angular Methods of feeding Tool when Cutting Thread in Lathe

that the necessary combination can be engaged by simply shifting the controlling handles or levers.

Methods of Feeding Tool Inward. — The inward feeding movement of a tool for each successive cut may be either at right angles to the axis of the screw thread, as indicated at *A*, Fig. 1, or at an angle of 30 degrees as shown at *B*. With the latter method the compound rest is set at an angle of 30 degrees. If the lathe is not equipped with a compound rest, the feeding movement must be as shown at *A*. The objection to this method is that the cutting action is not so good as when one edge of the tool does practically all the cutting, as at *B*, and the other edge moves parallel to the opposite side of the thread. The angular method of feeding the tool does not tend to tear the thread as when the tool is fed straight in, and a smoother thread is cut.

After most of the metal has been removed by the angular feeding method, the tool may be moved straight in to take a light finishing cut.

The thread tool illustrated at *C* is intended especially for feeding in at an angle. This tool is given top rake and all the cutting is done on one side. As the illustration shows, the compound rest is set at an angle of 30 degrees for cutting 60-degree threads such as the U. S. standard or sharp V-threads. The point of the tool forms one side of the thread as it feeds in at this angle and the cutting edge forms the opposite side. This form of tool cuts easily, because of the top rake or slope, and it is particularly adapted for coarse threading operations. Sometimes an ordinary thread tool is used for taking a light finishing cut after roughing out the thread with a tool of the type referred to.

Return of Tool for Successive Cuts. — There are two ways of returning the lathe carriage and tool to the starting point for taking another cut after one or more cuts have been completed. One method is by disengaging the carriage from the lead-screw and returning it by hand; the other is by allowing the carriage to remain in engagement with the lead-screw and reversing the lathe or lead-screw at the completion of each cut. If the number of threads per inch on the screw being cut is a multiple of the number per inch on the lead-screw, the carriage may be disengaged and reengaged with the lead-screw at random and the tool will always follow the original or first thread groove that was cut; when the number, however, is not a multiple of the number on the lead-screw, the tool may not engage the thread properly. When it is necessary to adopt some method of keeping the tool in the right relation to the work, if the screw is quite short the carriage may remain in engagement with the lead-screw until the thread is finished, but, for cutting comparatively long screw threads, this method of returning the carriage would require too much time and it can be returned more quickly by hand. When lathes have exposed change-gears, marks are sometimes made on the gears to insure re-engaging the carriage lock-nut with the lead-screw at the right

time; most of the modern lathes, however, are equipped with an indicator or thread chasing dial for "catching the threads."

Principle of Chasing Dial or Thread Indicator. — The thread chasing dial of an engine lathe is attached to the carriage and has a worm-wheel (see Fig. 2) that meshes with the lead-screw. The vertical spindle or shaft of this worm-wheel carries a graduated dial which shows when to reengage the carriage with the lead-screw when cutting screw threads which are not a multiple of the number per inch on the lead-screw. The number of teeth in the worm-wheel of the indicator should be a multiple of

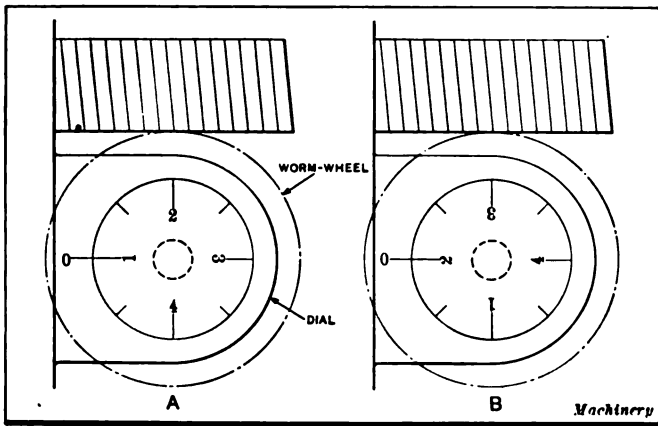

Fig. 2. Diagrams illustrating Arrangement of Thread Chasing Dial or Indicator

the number of threads per inch on the lead-screw, and the number of main divisions on the dial should equal the number of teeth on the worm-wheel divided by the number of threads per inch on the lead-screw. Each main division will then represent an inch of carriage travel. For instance, if the lead-screw has six threads per inch and the worm-wheel twenty-four teeth, then there should be $\frac{24}{6} = 4$ main divisions or graduations on the dial.

Assume that 11 threads per inch are being cut and that the carriage was engaged with the lead-screw when graduation line No. 1 was opposite the zero line on a stationary part of the indicator as illustrated at A. If the tool were withdrawn from the

thread groove and moved back a distance equal to one-sixth inch, or one lead-screw thread, it would not be opposite a thread groove on the work; the same would be true for a backward movement equal to two, three, four, or five threads on the lead-screw, but a movement of six lead-screw threads, or one inch (as indicated by *B*), would bring the tool in line with a thread groove eleven threads away from the point of disengagement; therefore, by always reëngaging the carriage with the lead-screw when one of the graduations representing an inch of travel is in line with the zero mark, the tool will follow the original cut. If in the preceding example the number of threads per inch being cut were ten instead of eleven, or any other even number, a half inch of backward movement would have located the tool directly opposite a thread groove; hence, if the four main divisions on the indicator dial previously referred to were subdivided, making eight divisions in all, any of these half divisions could also be used for "catching the thread" when cutting an even number of threads per inch. If $11\frac{1}{2}$ threads per inch were being cut, those graduations on the dial representing a movement equivalent to two inches or twenty-three threads on the work would be used when reëngaging the carriage and lead-screw. For instance, suppose there are four main divisions on the dial, each representing one inch of carriage travel and numbered 1, 2, 3, and 4, as shown; then if engagement were made for the first cut when, say, line No. 1 was opposite the zero mark, either this line or line No. 3, two divisions from it, would indicate the point of engagement for succeeding cuts. Some indicator dials have a circle of graduations for even numbers of threads per inch, representing a half-inch carriage travel; another circle of graduations for odd numbers representing inches of carriage travel; and a third circle for fractional pitches (like $11\frac{1}{2}$ threads per inch) representing two inches of carriage travel.

Cutting Multiple Screw Threads.—When cutting multiple screw threads, the general method of procedure is about the same as for single screw threads, except that the lathe must be geared according to the number of single threads per inch, (or with

reference to the *lead* of the thread, not the pitch, and provision must be made for locating the tool when cutting the different thread grooves. The tool may be located (1) by indexing or turning the piece being threaded a fractional part of a revolution; (2) by setting the compound slide parallel with the screw thread being cut so that the slide can be used for adjusting the tool; (3) by disengaging the lock-nut from the lead-screw while the lathe spindle is stationary, moving the carriage the required distance; (4) by engaging the lead-screw at the proper time (with the lathe in motion), as shown by graduations on the thread chasing dial or indicator.

Indexing for Multiple Thread Cutting. — When the screw is indexed for locating the tool in connection with thread cutting, it is given one-half turn for a double thread, one-third turn for a triple thread, one-fourth turn for a quadruple thread, and so on. An easy method of indexing for a double thread when the work is held between centers is simply to remove the part from the lathe and turn it one-half revolution by placing the driving end of the dog in the opposite slot of the faceplate. The objection to this method is that any error in the location of the faceplate slot would be reproduced in the screw thread. Another common method (when using the change-gear type of lathe) is to disengage the stud gear and idler gear after marking whatever tooth happens to be in mesh, and then turn the spindle half a revolution for a double thread, one-third revolution for a triple thread, etc. If the ratio of the gearing between the stud and the spindle were other than 1 to 1, this would affect the indexing movement; moreover, in order to apply this method, the number of teeth in the stud gear must be evenly divisible by 2 for a double thread, 3 for a triple thread, and so on. A convenient method of indexing multiple-threaded screws is by means of a special faceplate formed of two parts, one of which is free to rotate after loosening the clamping bolt. Graduations on the edge or periphery of one plate are used for turning the adjustable section the required amount.

Use of Compound Rest for Adjusting Tool. — When a lathe has a compound rest, this may be used for adjusting the tool

when cutting the different thread grooves of a multiple screw thread. The compound rest is set parallel to the axis of the screw, as shown in Fig. 3, and after one thread groove is cut, the tool is moved a distance equal to the pitch of the thread or one-half the lead for a double thread, one-third the lead for a triple thread, etc. When the feed-screw has a graduated dial, this adjustment of the tool can easily be made. The compound-rest method is very convenient and has the advantage over the use of a special faceplate that parts may be held in the chuck for



Fig. 3. Compound Rest set Parallel to Axis of Screw for Adjusting Tool when Cutting Multiple Thread

internal threading operations. The accuracy of the tool adjustment and of the screw that is cut depends upon the accuracy of the feed-screw of the compound-rest slide; ordinarily, the errors from this source would be so small as to be negligible.

Adjusting Tool by Shifting Carriage. — When a tool is located for cutting different thread grooves of a multiple screw thread by shifting the carriage and tool, the adjustment must be such that, when the tool is in the correct position, the lock-nut may be reengaged with the lead-screw. If a double thread is being cut having a lead of, say, one inch, the tool could be

located for cutting the second thread groove by disengaging the lock-nut (with the lathe spindle stationary) and moving the carriage back a distance equal to the pitch of the thread, or one-half inch. If the adjustment were equal to the pitch plus the lead or the pitch plus any multiple of the lead, the tool would still be in position for cutting the second thread groove. In actually cutting a screw thread, it would, of course, be necessary to move the carriage far enough for the tool to clear the end of the work before starting another cut; for instance, if the tool were 10 inches from the starting end and a double thread having a one-inch lead were being cut, the carriage should be moved at least $10\frac{1}{2}$ inches. This adjustment could also be obtained in this particular case, if the lead-screw had an even number of threads per inch, by moving the carriage and tool $\frac{1}{2}$ inch (pitch of thread) and then, after reëngaging the lock-nut, turning the lathe backward to secure the necessary additional movement.

Whether or not the lock-nut can be reëngaged with the lead-screw after shifting the carriage a given distance may be determined as follows: If the carriage is moved a whole or even number of inches (not fractional), the lock-nut can be reëngaged with any lead-screw having a whole number of threads per inch. If the number representing the carriage adjustment is fractional, the number of threads per inch on the lead-screw must be divisible by the denominator of the fraction.

Use of Indicator for Multiple Thread Cutting. — The thread chasing dial or indicator may sometimes be used to advantage for engaging the tool with the different multiple thread grooves when cutting a screw thread of this kind. By means of the indicator, the engagement of the lock-nut with the lead-screw is so timed that the tool, after taking a cut through one thread groove, will be in position to cut the other groove or grooves, as the case may be, before feeding the tool inward, instead of finishing one groove at a time. To illustrate, suppose a double-threaded screw is to be cut having a lead of $\frac{1}{2}$ inch ($\frac{1}{4}$ inch pitch) or two single threads per inch. Assume that the lead-screw of the lathe has 4 threads per inch, the indicator worm-wheel 24 teeth, and the dial 6 main divisions, representing inches of

carriage travel, and 6 subdivisions representing half inches of carriage travel. Since the number of threads per inch is even in this case, the lock-nut may be engaged with the lead-screw when any division line on the dial is opposite the zero mark, and the tool will follow the original cut. After taking a cut in one thread groove and moving the carriage back to the starting point, the lock-nuts are next engaged when the zero line is midway between any two lines on the dial; the tool will then

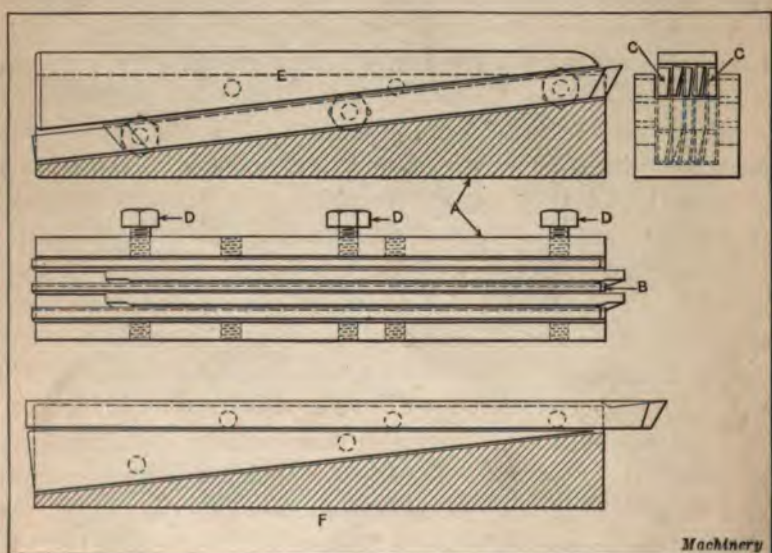

Fig. 4. Multiple Tool for Cutting Both Grooves of Double Thread simultaneously

cut another groove midway between the first one, or a distance from it equal to the pitch of the thread. If there were an odd number of single threads per inch, say, three, engagement would be made on any main division line for cutting one groove of a double thread, and on any subdivision for the other groove.

Multiple Tool for Cutting Multiple Threads.— The different thread grooves of a multiple screw thread may be cut at the same time by using a tool for each groove, the tools being spaced according to the pitch of the thread. The Dale multiple-tool holder is shown in Fig. 4. This particular holder is arranged

for cutting square threads, although the same general type may be applied to other forms. The main part of the holder *A* is channeled or grooved to receive the cutting blades or tools. The space between these tools is regulated by the distance piece *B*, and they are held at an angle by tapering strips *C* (see end view). This inclination varies with the pitch and diameter of the screw thread. The tools and strips *B* and *C* are held in position by set-screws *D*. The tapering part *E* above the tools provides a horizontal surface for clamping the tools in position in the tool-holder. When this holder is used for cutting Acme or other screw threads of angular form, the tools are held in a

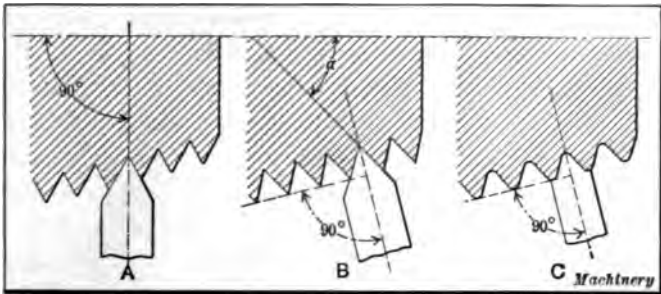

Fig. 5. Correct and Incorrect Positions of Tool for Taper Thread Cutting

horizontal position by inserting a tapering piece beneath them as shown at *F*. A flat plate is then applied to the top to form a bearing surface for the tool-holder clamping screw. The blades used in this holder are of the same section throughout their length to provide for repeated grinding.

Position of Tool for Cutting Taper Threads. — It is the general practice in the United States to set a tool for cutting tapered screw threads as shown at *A*, Fig. 5, or so that the sides of the thread incline equally with reference to a line perpendicular to the axis of the screw. The principal reason why taper threads should be cut with the tool in this position is that taper taps are made in this way or with the threads normal to the axis. If the tool were set in the position shown at *B* or so that the sides of the thread incline equally with reference to the tapering surface,

obviously such a thread would be a poor fit in a hole tapped with an ordinary taper tap having threads normal to the axis as at *A*. If the hole and the tapering part which screws into it were both threaded normal to the surface as at *B*, the thread would be satisfactory unless there were an unusual amount of taper. In extreme cases, angle α (see diagram *B*) of one side of the thread might be so small that the radial or bursting pressure on the nut would be excessive owing to the wedging action. It is the practice to cut Whitworth pipe threads and most other Whitworth threads which are tapering with a tool set perpendicular to the side of the tapering surface, as shown at *C*, because the same tools that are used for parallel threads can then be used for taper threads. If a tool used for parallel thread cutting were set at right angles to the axis, one side of the crest of the thread would not be cut to a circular form if the tool were of the shape illustrated, because the curved cutting edges would be the same distance from the axis of the screw and only one side of the circular part of the tool would cut. This difficulty is not encountered with the thread forms like the U. S. standard or V-threads.

The top cutting face of the tool should lie in a horizontal plane coinciding with the axis of the work for all taper thread cutting. It is much more important to have the tool at the same height as the lathe centers when cutting taper threads than when cutting parallel threads for the reason that a section parallel to the axis of a cone is not straight but curved; consequently, not only is the angle of the thread changed but a curved tapering thread also is produced.

Adjustment of Lathe for Taper Thread Cutting. — An engine lathe equipped with a taper attachment should be used for taper thread cutting, if possible. When the required taper is obtained by setting the tailstock off center, the thread will not advance at a uniform rate or form a true helix, especially when an ordinary bent-tail driving dog is used. This "drunken thread" or error is caused by the angularity between the driving dog and the faceplate, which causes the rotating speed of the work to vary during each revolution. The bearing surface between the lathe centers and the work-centers when the tailstock is offset is

another cause of inaccuracy, because as the work-centers wear rapidly on account of the poor bearing surface, the angle of the taper is changed as the tailstock spindle is tightened. The amount of these errors depends upon the angle of the taper and the distance that the centers must be offset. When a plain (not threaded) gage of the required taper is available this may be used for adjusting the taper attachment accurately prior to the thread-cutting operation. The taper gage is placed between the centers (which should be in line) and a dial indicator is fastened in the tool-holder. The carriage is then traversed while the indicator is in contact with the taper gage, and the taper attachment is adjusted until the hand of the indicator remains practically stationary as it is traversed from one end of the gage to the other. This method has been employed in making thread gages of the plug form. Many tapering threads, especially when large numbers of duplicate parts are required, are cut by means of chasers or special dies.

Internal Thread-cutting Operations. — The general methods of cutting internal threads in the engine lathe are: (1) by a single-point tool; (2) by using a tap supported by the tailstock spindle; (3) by using a single-point tool followed by a tap; (4) by using a multiple-point tool of the chaser class. The single-point tool is used for most internal thread-cutting operations. If the hole to be threaded is quite small in diameter, it is difficult to cut an accurate thread with a single-point tool, especially if the hole is quite long or deep, because of the flexibility of a tool small enough to enter the hole. On work of this kind, a tap may be used or the thread is sometimes cut slightly under size with a single-point tool, and a tap having its shank or outer end held straight by the tailstock center is run through the hole for taking a light finishing cut.

Gaging Single-point Thread Tools. — The accuracy of a screw thread cut in a lathe may be affected as to pitch or lead by the lead-screw, and as to the angle or form of thread by the tool used for the thread-cutting operation or its position when in use. For ordinary work, the tool is ground either by hand or, preferably, by the use of a special tool grinder of the type used for sharpen-

ing turning and planing tools. When the angle of the cutting edge is being tested by a gage, the latter should be held in the same plane as the cutting edge, as at *A*, Fig. 6, and not at right angles to the front side, as shown by the dotted lines, assuming that the notch in the gage conforms to the standard thread angle. If the clearance angle α of a tool is 15 degrees, the angle in a plane at right angles to the front face is about 61 degrees 45 minutes, when the angle in the plane of the cutting edge is 60

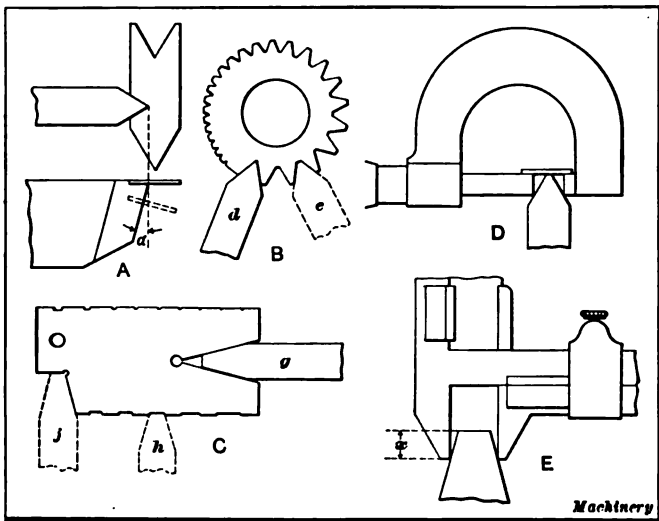

Fig. 6. Methods of gaging Thread-cutting Tools

degrees; hence, if the tool were ground to fit a gage held as shown by the dotted lines at *A*, the angle of the cutting edge would be too small. At *B* is shown a simple form of gage for testing U. S. standard thread-cutting tools. These tools have a flat end or edge equal in width to one-eighth the pitch of the thread. This particular gage has notches marked for different pitches. The tool is first ground to a 60-degree angle, the V-shaped notch in the gage being used as shown at *d*. The point is then ground off to the right width or until the tool fits into a notch corresponding to the required pitch, as illustrated at *e*.

An Acme thread gage is shown at *C*. This gage also has

notches for different pitches. The 29-degree notch at the end of the gage is used first for testing the angular sides of the tool when grinding as at *g*. The shallow notches are used simply for testing the width of the cutting edge at the end as at *h*, the numbers opposite the notches representing the number of threads per inch. The angle between the side and the end may be tested as illustrated at *j*. The tool may also be set square with the work by placing one edge of the gage against the turned surface and adjusting the tool until it coincides with the gage, as indicated by the dotted lines at *j*. The width of an Acme thread tool equals $0.3707 \times \text{pitch} - 0.0052$.

Testing Width of Flat End of U. S. Standard and Acme Thread Tools. — The width of the flat or end of either a U. S. standard or Acme thread tool may be measured by using an ordinary micrometer as illustrated at *D*. In measuring the tool, a scale is held against the spindle and anvil of the micrometer and the end of the tool is placed against this scale. The micrometer is then adjusted to the position shown, and, for a U. S. standard thread tool, 0.2887 inch is subtracted from the reading; the result equals the width of the tool point which should equal one-eighth the pitch. For an Acme thread tool, 0.1293 inch is subtracted from the micrometer reading to obtain the width of the tool point. The constants (0.2887 and 0.1293) which are subtracted from the micrometer reading are only correct when the micrometer spindle has the usual diameter of 0.25 inch. The value or constant for any other spindle diameter could be obtained by multiplying twice the spindle diameter by the tangent of one-half the thread tool angle.

An ordinary gear tooth caliper may also be used for testing the width of a thread tool point, as illustrated at *E*. If the measurement is made at a vertical distance x of $\frac{1}{4}$ inch from the points of the caliper jaws, the values previously given for U. S. standard and Acme threads should be subtracted from the caliper reading to obtain the actual width of the cutting end of the tool.

When a tool for cutting a U. S. standard thread is accurate as to the angle and width of the point or flat, an accurate screw

may easily be cut by the following method: First turn (or grind) the screw blank to the outside diameter of the screw within whatever limits of accuracy are considered necessary. Before starting the thread-cutting operation, adjust the tool inward until its front edge just touches the surface of the blank, and then feed the tool inward for taking successive cuts until it has moved a distance equal to 0.6495 times the pitch of the thread. If the cross-feed screw does not have a micrometer dial for measuring the movement of the tool, the movement of the tool-slide may be gaged by attaching a pin or block to it and measuring from a fixed pin or block. In the case of an Acme thread, the inward movement of the tool should equal one-half the pitch of the thread plus 0.010 inch.

Width of Tool Point for Cutting Square Threads. — In order to provide clearance between the threads of a square-threaded screw and nut, the width of the thread groove in the nut is made somewhat greater than one-half the pitch of the thread. The width of the point of the tool for cutting external screws with square threads should be exactly equal to one-half the thread pitch, but the width of a tool used for cutting the threads on taps which are afterward to be used for tapping nuts should be slightly less than one-half the pitch so that the cutting teeth are a little wider than the theoretical standard width. The thread groove cut in the nut will then be slightly wider than the thread on the screw, thus providing the necessary clearance. An inside threading tool for threading nuts evidently should be of the same width as the teeth on the tap, or slightly wider than one-half the pitch. The widths of the points of tools for all ordinary pitches from 2 to 14 threads per inch are given in the table on page 32, which includes tools for threading taps, cutting screws, and cutting the threads in nuts.

Use of Thread Chasers in the Lathe. — A chaser is a form of threading tool having a number of teeth instead of a single point like the threading tools commonly used for screw cutting in the engine lathe, although the term "thread chasing" is often used to indicate the cutting of a thread with a single-point tool. The two general classes of chasers (exclusive of those used in

dies) are hand chasers and threading tool chasers. The former are hand-controlled, and the latter are rigidly held in a tool-holder and used like an ordinary lathe threading tool. Two types of hand chasers are shown at *A* and *B* in Fig. 7. Form *A* is used for chasing external threads and form *B* for internal threads. When the tool is in use, the cutting end is supported by some form of rest held in the toolpost. These hand chasers are convenient for truing up battered threads or for reducing the size of a part which has been threaded by either a die or a

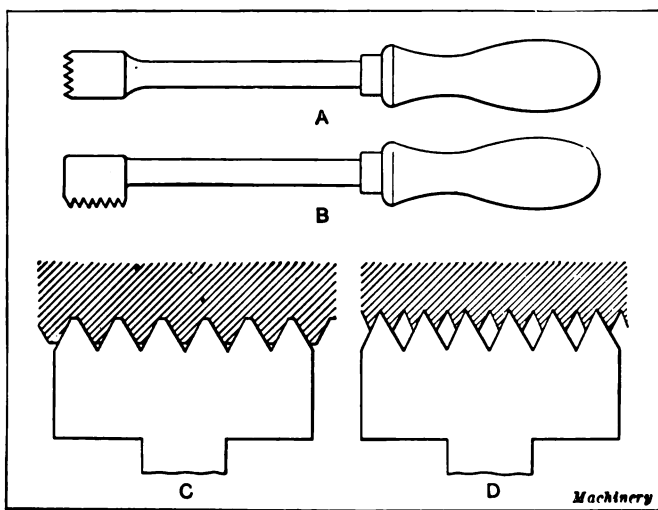

Fig. 7. Hand Chasers — Threading Tool Chasers

single-point tool. Tools of this kind are especially adapted for brass work. The chaser used in any case has teeth spaced to correspond to the pitch of the thread. This form of tool can be applied to the work quickly and without gearing the lathe for a thread-cutting operation.

Threading tool chasers which are held rigidly in the tool-holder are used practically the same as a single-point tool, the lathe being geared for traversing the tool along the work in order to control the lead of the thread. Tools of this kind cut threads rapidly and may be used for roughing out threads preparatory to finishing them with a regular single-point tool.

Many screw threads are also finished completely with chasers of this type, although they are not adapted for extremely accurate work unless the teeth are ground after hardening, because the pitch of the chaser teeth is affected more or less by the hardening operation. A threading tool chaser for a U. S. standard thread is shown at *C*. The spaces between the teeth extend to a sharp vee instead of having flats the same as the cutting ends, in order to provide clearance for the top of the thread.

Widths of Ends of Tools for Cutting Square Threads

Number of Threads per Inch	Width of End of Tool		
	For Taps	For Screws	For Internal Threads
2	0.2475	0.2500	0.2525
2½	0.1975	0.2000	0.2025
3	0.1641	0.1666	0.1691
3½	0.1408	0.1428	0.1448
4	0.1235	0.1250	0.1265
4½	0.1096	0.1111	0.1126
5	0.0985	0.1000	0.1015
5½	0.0894	0.0909	0.0924
6	0.0818	0.0833	0.0848
7	0.0699	0.0714	0.0729
8	0.0615	0.0625	0.0635
9	0.0545	0.0555	0.0565
10	0.0490	0.0500	0.0510
11	0.0444	0.0454	0.0464
12	0.0407	0.0417	0.0427
13	0.0375	0.0385	0.0395
14	0.0352	0.0357	0.0362

The pitch of the chaser teeth does not always equal the pitch of the thread to be cut. For instance, the chaser illustrated at *D* has a pitch double that of the screw thread. Every alternate groove is engaged, but as the lathe is geared for the pitch of thread to be cut, each tooth of the chaser follows the thread groove the same as though it were a single tool. Chasers are sometimes made as shown at *D* for cutting very fine threads, because, in this way, larger and stronger teeth are obtained.

Tools for Cutting Whitworth Threads. — The Whitworth form of thread, or the British standard, may be cut by using a single

tool of the form illustrated at *A*, Fig. 8. This tool is so shaped that it finishes the rounded crest of the thread as well as the angular sides and the root. As this tool is rather difficult to make, many Whitworth threads, especially in jobbing and repair shops, are cut by using two tools as illustrated at *B*. One finishes the angular sides and the root, whereas the other is used for finishing the crest of the thread, as the illustration shows. In British machine shops, threads of ordinary pitches

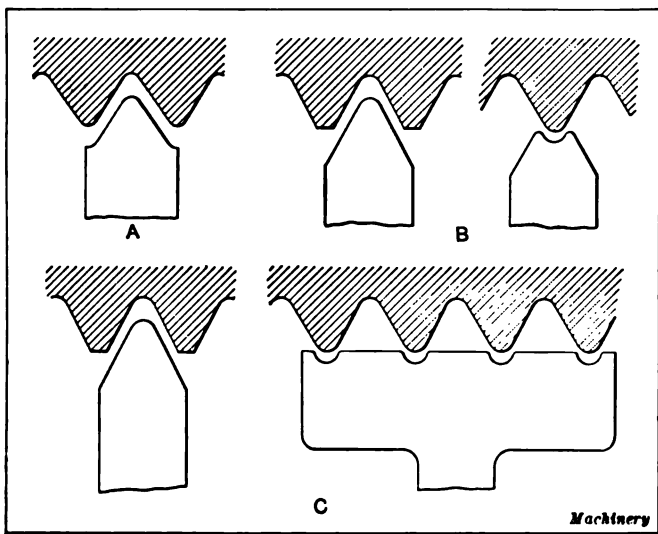

Fig. 8. Different Forms of Tools for Cutting Whitworth Threads

are often cut as indicated at *C*. After the angular sides and root of the thread have been finished by a tool having a rounded point, the crest of the thread is rounded off by using a hand chaser. The radii of both the crest and the root of a Whitworth thread equal 0.1373 times the pitch, and the depth of the thread equals 0.6403 times the pitch. The angle between the sides as measured in an axial plane is 55 degrees.

Cutting a Thread with a Revolving Tool. — When it is necessary to thread a part that will not swing in the lathe on account of a projecting member that will not clear the lathe bed, it is

sometimes possible to mount the work on the carriage and revolve the tool. The work is bolted or otherwise attached to the carriage so that whatever surface is to be threaded is concentric with the lathe spindle. The tool may be fastened to one of the jaws of a chuck to provide radial adjustment, and the thread is then cut in the usual manner.

Forming Threads by a Revolving Steel Disk. — Screw threads have been formed on manganese steel pins, studs, etc., by traversing a rapidly revolving hardened tool-steel disk along the blank to be threaded. The disk has a V-shaped edge or periphery of the same angle as the thread and serves to form the thread groove. This disk has a peripheral speed varying between 3000 and 4000 feet per minute and, when a thread is being formed, the edge of the disk is forced against the slowly revolving blank. The heat generated by friction softens the material so that the disk removes the stock in the form of small thin scales. The operation is slow and expensive and this method has been employed because it seemed to be the only practicable way of doing the work. The attachment consisting of the disk, disk spindle, driving pulley, and suitable spindle bearings was mounted on the slide-rest of an ordinary lathe, the disk being driven independently from an overhead drum. The blank to be threaded was mounted between the lathe centers and the disk traversed along by the lead-screw of the lathe, the same as when cutting a thread in the usual manner. This rapidly revolving disk operates in practically the same way as the well-known friction saw, except that it is necessary to avoid excessive heating of the steel to be threaded, as this would injure the quality of the steel and might burn the thread. When the hardened disk is at work, the temper is not drawn (although the material being threaded is heated sufficiently to soften it), because the disk is revolving very rapidly and the work slowly, so that any section or unit of length along the periphery of the disk is in contact with the work a very short time as compared with a given point on the work; consequently, the disk has a much greater time for cooling than the work which accumulates the generated heat.

Automatic Threading Lathe.—The automatic threading lathe built by the Automatic Machine Co., Bridgeport, Conn., is especially adapted for threading duplicate parts in quantity, because the movements of the lathe are automatically controlled

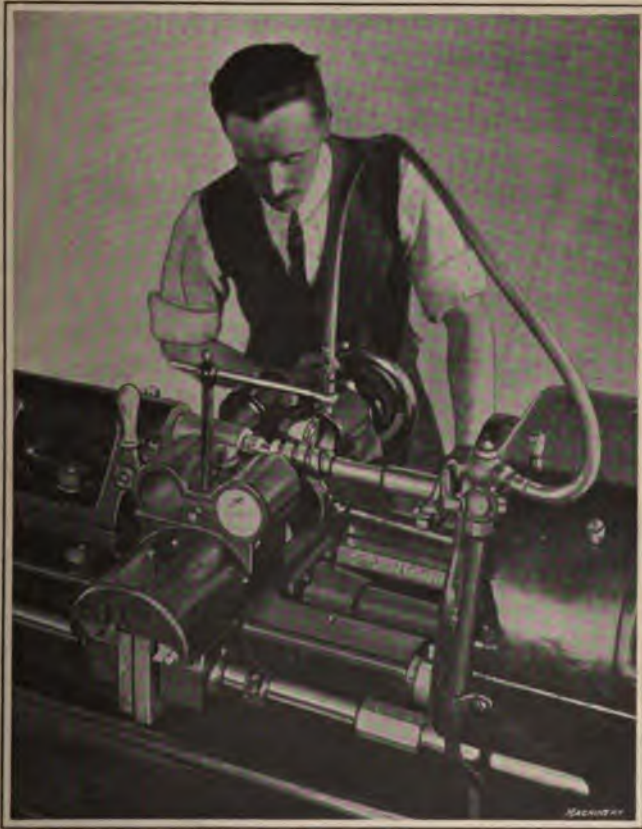

Fig. 9. Automatic Threading Lathe Cutting Screw Thread

after the work is placed in position and the lathe is started. As the forward and return movements of the carriage and the movements of the tool are controlled mechanically, the machine operates more rapidly and continuously than an ordinary engine lathe. A detail view of the machine having a geared headstock and the work is shown in Fig. 9. The headstock is arranged for

varying the forward cutting speed and for reversing the rotation of the spindle, the latter being effected automatically at the completion of the cut. The carriage has front and rear tools and, when the machine is in operation, these tools are fed in automatically to the required depth; the carriage is then traversed along the bed by a central lead-screw, and when the tools reach the end of the cut, they are automatically withdrawn and the carriage is returned to the starting point. The tools are then fed in again far enough for taking a new cut, and the cycle of operations is repeated until the thread is finished to the size for which the machine is set, when the feeding of the tools is automatically stopped.

Cutting Tools of Automatic Lathe. — There are four positions or holders for cutting tools on the automatic lathe (see Fig. 9). For external work, two tools are used, one being located at the front and the other at the rear, as previously mentioned. When cutting a thread close to a left-hand shoulder, the two left-hand positions or holders are utilized, and if the shoulder is on the opposite side, the two right-hand holders are employed. By using two cutting tools for external work, it is possible to have one tool cut one wall or side of the thread while the other tool operates on the opposite side of the thread. When the tools are applied in this way, they may be ground with top rake in order to secure a better cutting action. When cutting an angular thread, such as the Acme or a worm thread, a square-nosed roughing tool is sometimes used in the rear and a form-finishing tool in the front. A finishing tool of the gooseneck or spring type is recommended. Another method of cutting a thread of similar form is to mount a single square-nosed roughing tool in advance of the front and rear tools. The square-nosed tool then cuts a rough groove which is finished by the two following tools, taking shearing cuts on opposite sides of the thread. When cutting a square thread, a roughing tool, which is about 0.02 inch narrow, is used, and the thread is finished to the required size by a tool in front. When cutting a double thread, both thread grooves may be cut simultaneously by using four tools; two parallel roughing tools operating in adjacent grooves are located at the

rear, and two finishing tools at the front of the machine. Change-gears are employed for adapting the machine to cut threads of different pitch.

Controlling Mechanism of Automatic Lathe. — One of the important features of this lathe is the back-shaft which controls the traversing movement of the carriage and the points of reversal, as well as the inward and outward movements of the cutting tools. When the carriage reaches the end of its travel at the completion of the cut, it comes against an adjustable

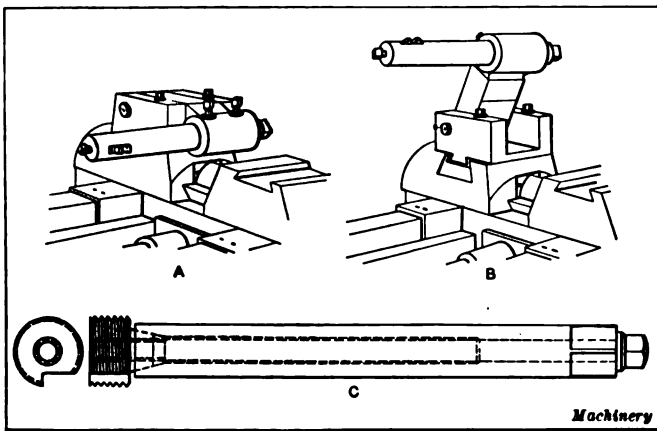

Fig. 10. (A and B) Swinging Type of Internal Threading Toolholder. (C) Internal Threading Bar with Chaser

collar on the back-shaft. The result is that the back-shaft is shifted longitudinally, and this endwise motion throws into engagement a mechanism at the headstock end of the machine, which causes the back-shaft to revolve one-half revolution. This rotation serves a double purpose in that it withdraws the two cutting tools from the work and, at the same time, reverses the motion of the lathe spindle. When the carriage reaches the end of the return movement, caused by the reversal of the spindle and lead-screw rotation, it encounters another stop on the back-shaft, so that the latter is again shifted in the opposite direction. This endwise movement again causes the back-shaft to revolve one-half revolution, which automatically moves the

tools inward for the next cutting stroke. The tools are moved a little farther inward for successive strokes by a ratchet and pawl mechanism.

Internal Thread Cutting on Automatic Lathe. — The automatic lathe may be used for internal as well as external thread-cutting operations. One type of tool-holder used for internal work is illustrated at *A* and *B* in Fig. 10. This tool-holder is known as the "clapper-box" type, because it has a block which is pivoted to permit swinging the tool-holder up out of the way

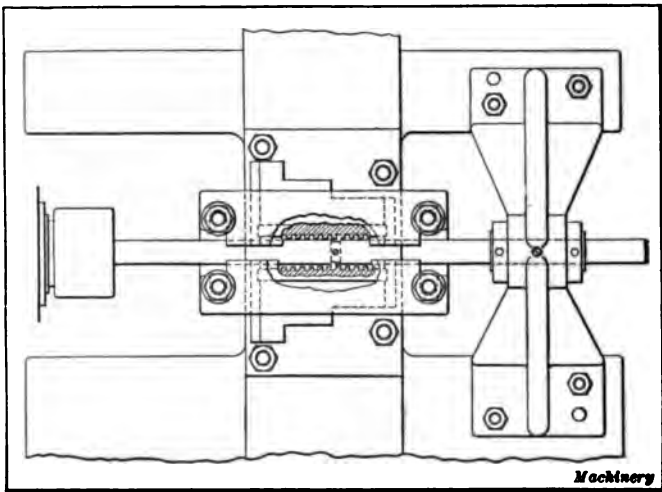

Fig. 11. Arrangement for Cutting Threads on Chuck Jaws in Automatic Lathe

as shown at *B*. This type of tool-holder is especially desirable when using plug gages for testing the size of the work, because the tool-holder can readily be moved out of the way for inserting the gage and it is not necessary to disarrange the automatic stops nor run the carriage back beyond its regular point of reversal. The tool-holder for internal threading may be provided with a roughing cutter followed by a finishing cutter. An internal threading bar having a chaser (see sketch *C*) is sometimes used.

An interesting example of internal thread cutting performed on the automatic lathe is illustrated by the diagram, Fig. 11,

which represents a plan view and illustrates a method of cutting the semi-circular threads along the rear sides of chuck jaws. These jaws are held in special fixtures mounted on the tool-slides and the threading tool bar is held in the lathe spindle and is supported at the outer end in a follow-rest. When the lathe is in operation, the tool-slides and the work move inward, and after the work is traversed past the cutting tools, the slides recede for the return movement.

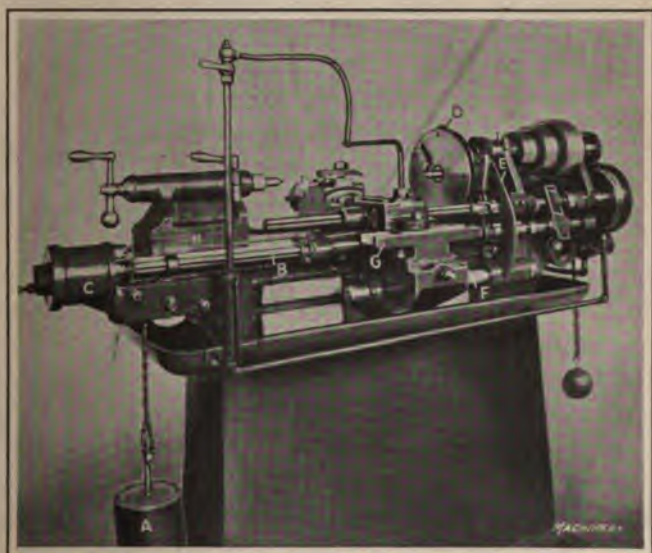

Fig. 12. Automatic Threading Lathe of Taper and Relieving Type

Automatic Threading Lathe of Taper and Relieving Type. — The automatic threading lathe illustrated in Fig. 12 is capable of cutting either a straight or taper thread on a tap and relieving the thread at the same time. This lathe is of the quick-return type, the carriage being drawn back to the starting point after the lead-screw nut has been released at the end of the cut. It is similar in this respect to the quick-return type of automatic lathe intended primarily for cutting screw threads of relatively fine pitch, which is so designed that the work revolves continuously in one direction. The weight *A* (see Fig. 12) causes the

rapid return movement of the carriage after the cutting tools have withdrawn and the lead-screw nut is released. The traversing movement of the carriage is controlled by stops on the back-shaft *B* and the shock at the end of the rapid return movement is absorbed by an adjustable air cushion formed in cylinder *C*. This machine has a taper attachment which operates on the same general principles as the taper attachment of an engine lathe. The in-and-out movement for relieving the teeth of the tap is derived from cam rolls *D* carried by the faceplate. These rolls, which are spaced according to the number of reciprocating movements required, engage a plate attached to arm *E*. This arm, in turn, is fastened to rock-shaft *F*, which, through a lever (not shown), imparts a cross-movement to the guide *G* of the taper attachment and to the tool-slide. The inward or cutting movement is positive, whereas the return movement is derived from a spring.

Change-gears for Screw-cutting Lathes. — The combination of gearing required for cutting a thread of given pitch seldom needs to be determined by the lathe operator, because, if the lathe is of the type having ordinary change-gears, an attached table or "index plate" shows what gears are needed; similarly, if the lathe is of the quick-change gear type, the positions of whatever controlling handles there may be are also indicated by a table for threads of different pitches included in the range of the machine. Occasionally, however, a machinist or toolmaker finds it necessary to determine what change-gears are required, particularly for some special thread-cutting operation.

In order to calculate what size gears should be used for a certain pitch of thread, the number of threads per inch that will be cut when gears of equal size are placed on the lead-screw and spindle stud should first be determined, either by referring to the index plate or by actual trial. (If the main spindle of the lathe and the spindle stud are geared in the ratio of 1 to 1, the number of threads per inch that will be cut when using gears of equal size will correspond to the number of threads per inch on the lead-screw.) This number, which will be referred to as the "lathe screw constant," is written down as the numerator of a

fraction, and the number of threads to be cut, as the denominator. The numerator and denominator are then multiplied by some trial number until products are obtained which equal the numbers of teeth in change-gears that are available. For instance, if the lathe screw constant is 4 and 12 threads per inch are to be cut, gears having 24 and 72 teeth could be used, assuming, of course, that such gears were supplied with the lathe. This result is determined as follows:

$$\frac{4}{12} = \frac{4 \times 6}{12 \times 6} = \frac{24}{72}$$

The trial number selected in this particular case is 6, and the product of this trial number and the numerator of the lathe screw constant equals the number of teeth in the gear for the spindle stud, whereas the product of the trial number and denominator equals the number of teeth in the gear for the lead-screw.

Compound Gearing for Thread Cutting.— In order to cut some pitches, it is necessary to use a compound train of gearing or four gears instead of two. The sizes of these gears may be determined in practically the same way as described for simple gearing. The lathe screw constant is written down as a numerator and the number of threads to be cut as the denominator of a fraction, but, before multiplying with the trial number, the numerator and denominator are resolved into factors. Each pair of factors (one factor in the numerator and one in the denominator are referred to as a pair) is then multiplied by the same trial number to obtain values representing numbers of teeth in gears that are available. To illustrate, if the lathe screw constant is 6 and $1\frac{3}{4}$ thread per inch is to be cut, the change-gears would be calculated as follows:

$$\frac{6}{1\frac{3}{4}} = \frac{2 \times 3}{1 \times 1\frac{3}{4}} = \frac{(2 \times 36) \times (3 \times 16)}{(1 \times 36) \times (1\frac{3}{4} \times 16)} = \frac{72 \times 48}{36 \times 28}$$

The driving gears, in this case, have 72 and 48 teeth, and the driven gears, 36 and 28 teeth, respectively. When the lead of the thread is expressed as a fraction of an inch, the correspond-

ing number of threads per inch should first be determined. In the case of a single thread, the number of threads per inch equals 1 divided by the lead.

Change-gears for Metric Pitches.—Screw threads based on the metric system of measurement usually have the lead of the thread expressed in millimeters. If the lathe to be used has a lead-screw cut according to the English system of measurement, the change-gears may be calculated as follows: Multiply the lathe screw constant by the lead of the thread in millimeters and the product by 5, to find the number of teeth in the spindle stud gear. The gear on the lead-screw should have 127 teeth.

Just how this rule is derived will be apparent by considering a simple example. Suppose the screw is to have a lead of 3 millimeters and the lathe screw constant is 4. The number of threads per inch equals $25.4 \div 3$, because there are 25.4 millimeters per inch. The ratio of the change-gears may be expressed by a fraction having the screw constant as the numerator and the number of threads per inch as the denominator. Thus:

$$\frac{4}{\frac{25.4}{3}} = \frac{4 \times 3}{25.4}$$

The first whole number by which 25.4 can be multiplied and obtain a whole number as the product is 5; hence, the numerator and denominator of the fractional expression are multiplied by 5. Thus:

$$\frac{4 \times 3 \times 5}{25.4 \times 5} = \frac{60}{127}$$

Therefore, a thread of 3 millimeters lead would require a 60-tooth gear on the spindle stud and a 127-tooth gear on the lead-screw.

If a screw having a given number of threads per inch is to be cut on a lathe having a metric lead-screw, first determine the "metric screw constant" or the lead of the thread in millimeters that would be cut with change-gears of equal size on the spindle stud and the lead-screw. The product of the num-

ber of threads per inch multiplied by the metric screw constant multiplied by 5 equals the number of teeth for the lead-screw gear. The gear on the spindle stud should have 127 teeth.

Translating Gears for Metric Pitches. — Lathes used for cutting threads based on either the English or the metric systems of measurement may be provided with translating gears. There are two gears having 50 and 127 teeth, respectively. The numbers of teeth in these gears represent the relation between the English and the metric systems of measurement; thus,

$$1 \text{ inch is equivalent to } 2.54 \text{ centimeters, and } \frac{1 \times 50}{2.54 \times 50} = \frac{50}{127}.$$

When these gears are in the train of gearing connecting the lathe spindle and lead-screw, the lathe may be geared for cutting a given number of threads per centimeter by using, in addition to the translating gears, the same gears that would be employed for cutting a similar number of threads per inch. For example, if a metric thread is to be cut having a pitch of 2 millimeters, or 5 threads to the centimeter, and translating gears are used, change-gears for cutting 5 threads per inch could be employed. In this case, 5 threads to the centimeter will actually be cut and not 5 threads to the inch, because the translating gears are used in conjunction with the regular gears, thus forming a compound train of gearing. If the gears for cutting 5 threads per inch should have 36 and 30 teeth, respectively, on the stud and lead-screw, the compound train of gearing for cutting 5 threads per centimeter would consist of driving gears having 50 and 36 teeth and driven gears having 127 and 30 teeth. The positions of either the driving or the driven gears could be transposed, if necessary, in order to make the gears mesh together properly.

CHAPTER III

THREAD-CUTTING ATTACHMENTS

A SPECIAL mechanism or some form of attachment may be used in connection with thread-cutting operations either in engine lathes, turret lathes, or other classes of machine tools which may or may not be employed ordinarily for work of this kind. An attachment is sometimes applied to an engine lathe for cutting a screw thread of unusually large lead or for other special operations, such as cutting threads which differ slightly in pitch from the standard pitch. Thread-cutting attachments are also applied to some turret lathes, so that threads may be cut by means of a single-point tool or chaser whenever a tap or die cannot be used to advantage.

Attachments for Cutting Screws of Large Lead. — When a lathe is used for cutting a screw thread of exceptionally large lead, or steep pitch, the change-gear mechanism may be subjected to excessive stresses if the power for traversing the carriage along the bed is transmitted from the lathe spindle to the lead-screw in the usual manner. This is due to the unusual distance that the carriage must move along the bed per revolution of the work in order to obtain a large lead. For instance, if the lead is such that the lead-screw must be revolved quite rapidly to move the carriage and tool a distance equal to the lead of the thread, each time the spindle makes one revolution, the teeth, especially on the first gear of the train, may be broken as a result of the excessive stress. One method of avoiding trouble of this kind is to apply power directly to the lead-screw, instead of to the spindle; motion is then transmitted from the high-speed member of the gear train to the low-speed member, as the lead-screw drives the spindle and the load on the gear teeth is reduced.

Another method of overcoming this difficulty is by driving the lead-screw from the gear on the cone pulley, a special "attachment" or gearing being used to transmit the motion. On one design of lathe arranged in this way, the cone pulley has a velocity ten times that of the spindle when the back-gears are engaged; consequently, by using the rapidly revolving cone gear as the driver in the train of gearing connecting with the lead-screw, the stress on the teeth is reduced proportionately. If it is assumed that the lead of a screw to be cut is $3\frac{1}{2}$ inches and that there are 4 threads per inch on the lathe lead-screw, the speed of the lead-screw relative to the spindle speed is 14 to 1. By driving directly from the cone gear, however, the ratio will be changed to 14 to 10, because the cone pulley revolves ten times as fast as the spindle; therefore, the power necessary for traversing the carriage is easily transmitted through the gearing, and without overstressing the teeth. The gearing on a coarse threading attachment of this kind may be arranged as follows: A double sliding gear on the reversing shaft inside of the headstock can be engaged either with the regular driving gear on the spindle or with a small gear at the end of the cone pulley. For cutting threads of large lead, the sliding gear is engaged with the cone gear and the back-gears are thrown into mesh. The sliding gear will then make ten revolutions to one of the spindle; consequently, if the lathe were geared to cut one thread per inch, it would cut a thread groove having a lead of ten inches when driving through the sliding gear and cone pinion. An attachment of this kind may be used for cutting oil-grooves in cylindrical parts and for similar operations, as well as for cutting screws of large lead.

Special Lead-screw for Coarse Pitches. — A rear view of a Lodge & Shipley lathe having a special lead-screw for cutting threads of large lead is shown in Fig. 1. This auxiliary lead-screw extends along the rear side of the bed, and when in use the back-gearing of the headstock is engaged; the drive is then from the large back-gear, through the change-gearing shown, to the special lead-screw. A long half-nut at the back of the carriage engages the threads of the lead-screw and is so arranged that it

may be raised or lowered by a cam operated by a handwheel at the front of the apron. The lead-screw is supported on the under side by a number of long shoes attached to the lathe bed. This lathe is equipped with the regular quick-change gear mechanism and a lead-screw at the front for ordinary thread-cutting operations with leads ranging from $\frac{3}{8}$ to 2 inches. The coarse-pitch threading attachment is used for leads varying from 2 to 15 inches.

Obtaining Slight Variations in Pitch. — It is sometimes necessary to cut a screw thread having a pitch which is slightly

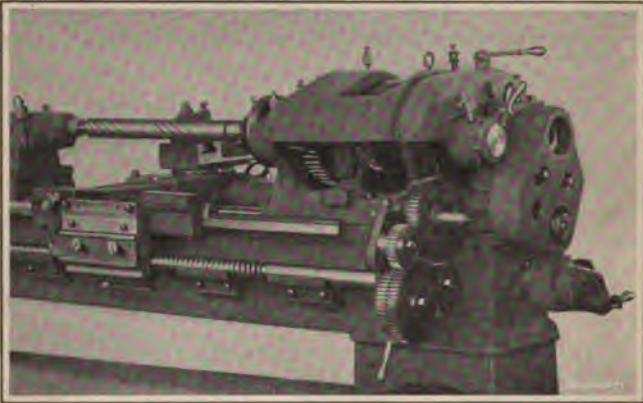

Fig. 1. Attachment for Cutting Threads of Coarse Pitch or Large Lead

greater or less than standard. A very small increase of pitch may be required in order to allow for shrinkage of the steel in hardening, or if a screw is to be fitted into a hardened part having an internal thread, it may be necessary to make the pitch of the screw thread less than standard on account of shrinkage in the nut or other part which is to receive the screw. A slight increase in pitch may easily be obtained by means of a taper attachment, but cutting a pitch less than standard is more difficult.

When a taper attachment is used to increase the pitch slightly, it is set at an angle and the part to be threaded is located at the same angle by adjusting the tailstock center; consequently, the

thread tool will cut a straight thread or one of uniform diameter throughout its length, but as the tool point moves along an angular path relative to the movement of the carriage, it travels farther than the carriage. The result is that the pitch of the thread cut by the tool is a little greater than the pitch for which the lathe is geared. The amount that the pitch is increased depends upon the angle between the axis of the work (or the angle to which the taper attachment is set) and a line representing the movement of the carriage. The cosine of the angle to which the work and taper attachment should be set for obtaining a given increase in pitch equals the standard pitch (obtained with the regular gearing) divided by the increased pitch necessary to compensate for shrinkage.

If a screw thread must be cut having a pitch slightly less than standard, special equipment is required. One method is to provide special gears which give a somewhat greater reduction of the pitch than is necessary. The taper attachment is then used, as previously explained, to increase the pitch so that it is below the standard just the right amount. For instance, if the required pitch is 0.198 inch instead of the standard of 0.200 inch (five threads per inch), gears having 83 and 84 teeth, respectively, could be used to form a compound train of gearing and reduce the 0.200-inch pitch obtained with the regular change-gears. This reduction would equal $\frac{83}{84}$ of 0.200 inch, or 0.1976 inch. In order to increase the pitch of 0.1976 inch to 0.198 inch, the taper attachment and work are set at an angle, the cosine of which equals 0.1976 divided by 0.198 equals 0.9979, which is the cosine of 3 degrees 40 minutes. As this example indicates, the pitch for which the lathe is geared is divided by the pitch required, to obtain the cosine of the angle.

Attachments for Changing the Pitch. — Lathes that are used extensively for precision screw cutting are sometimes equipped with special compensating attachments for varying the pitch. These attachments may be used in some cases to cut screw threads which differ slightly from the standard pitch, as when an allowance must be made for shrinkage, or the attachment may be used to compensate for slight inaccuracies in the lead-

screw in order to cut threads to a given pitch within as close limits as possible. Most of these attachments are designed to vary the pitch either by imparting a turning movement to the nut engaging the lead-screw, or by shifting the lead-screw itself in a lengthwise direction. The diagram, Fig. 2, illustrates how slight variations may be obtained by turning the lead-screw nut or as a result of a differential motion between the lead-screw and the nut connecting with the tool carriage. A nut of special form is mounted in a bracket attached to the carriage so that it

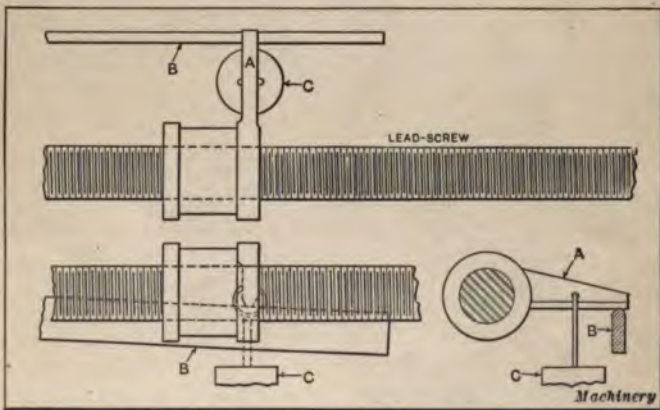

Fig. 2. One Type of Attachment for Obtaining Slight Variations in Pitch or for Correcting Lead-screw Errors

is free to turn. Projecting from this nut there is an arm *A*, the end of which is held firmly against the edge of a compensating strip *B* by weight *C*. The strip *B* can be set in an inclined position, so that, when arm *A* is traversed along it, the nut is turned in one direction or the other, thus increasing or decreasing the pitch of the thread cut by the lathe, by advancing or retarding the movement of the carriage.

The diagram, Fig. 3, illustrates a type of compensating attachment which operates by moving the lead-screw axially. The lead-screw bearing at one end is in the form of an externally threaded sleeve *A*, which is screwed into an outer stationary sleeve *B*. The lead-screw is free to rotate in sleeve *A*, and it can be moved in a lengthwise direction relative to sleeve *B* when

sleeve *A* is screwed in or out of sleeve *B*. The turning movement of sleeve *A* for varying the pitch is derived from a pinion attached to *A* which meshes with a rack *C* having at its lower end a block engaging a slot in plate *D*. This plate *D* is attached to a slide *E*, which is connected to the lathe carriage by a rod *F*; consequently, slide *E* and plate *D* move with the carriage, and when slot *D* is in an angular position the resulting vertical movement of rack *C* turns sleeve *A* and shifts the lead-screw, thus varying the pitch of the thread cut by the lathe.

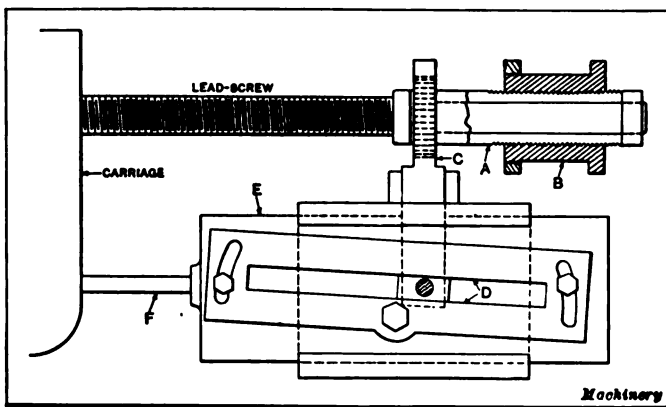

Fig. 3. Another Form of Attachment for Obtaining Slight Variations in Pitch

Quick - threading Attachment for Engine Lathe.—The Hendey quick-threading attachment shown in Figs. 4 and 5 is intended especially for cutting comparatively short threads on duplicate parts varying from one to three inches in length, although it may be used for lengths up to six inches. Thread cutting can be done rapidly with the attachment owing to the high speed at which the carriage is returned from the end of the cut to the starting point. This rapid-return movement is effected by a quick-return sleeve having a multiple thread of coarse pitch. This return sleeve, as well as the thread chasing sleeve from which the forward movement is derived, rotates constantly when the attachment is in use. The length of the travel in either direction is governed by automatic trip-dogs.

The chasing sleeve Y and the quick-return sleeve H are geared together and rotate at the same speed as the lead-screw. The nuts Z and Z_1 , attached to rocker Q , may be engaged with the sleeves. Rocker Q is connected with the apron by means of push-shaft I through the handle indicated at X . When the split nut in the apron is disengaged, rotation of the lead-screw will move the carriage in one direction when nut Z is engaged with the chasing sleeve Y , and the rapid-return movement is obtained when nut Z_1 and sleeve H are in engagement. The dogs T_1 and T_2 determine the limits of travel by striking stop-

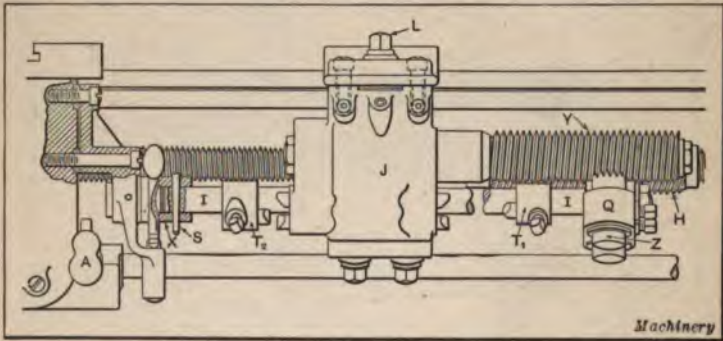

Fig. 4. Quick-threading Attachment for Engine Lathe

pins on bracket J , which throws the handle X and rocker Q to the neutral position, in which position neither nut is in engagement.

If a right-hand thread is to be cut, the change-gears in the gear-box of the lathe are set for whatever pitch may be required, and the regular reverse handle A is thrown downward and left in that position. The attachment should be clamped tightly to the bed by means of clamp screw L at a point which will allow of the desired amount of travel. Handle X is placed in the neutral position and the two dogs T_1 and T_2 , marked "R" (which signifies right-hand), are placed on shaft I . The latter is then connected with X by the taper pin S . The dogs are set by running the carriage by hand to the point where it is to stop, and then sliding the corresponding dog along shaft I until it engages the stop-pin. Assuming that the first cut is to be taken

with the carriage at the tailstock end and that the lathe is in motion, throw handle *X* up to the cutting position (see Fig. 5), keeping the pressure on the handle until nut *Z* engages the thread on sleeve *Y*. The carriage will then travel along until the dog *T*₁ throws the rocker *Q* and handle *X* to the neutral position. After withdrawing the threading tool, handle *X* should be thrown down to the reverse position with a rapid movement, thus causing the carriage to return rapidly to the starting point; then dog *T*₂ throws nut *Z*₁ out of engagement with sleeve *H*, and the carriage stops. This cycle of movements is repeated for each successive cut until the thread is completed. When cutting left-hand threads, the dogs marked "L" (left-hand) are substituted for those marked "R" and the regular reverse handle *A* is placed in the upper position. The operation of the attachment is the same for a left-hand thread as for

one of the opposite hand, except that the quick-return movement is toward the lathe headstock. When using this attachment, the operating handle *X* should be thrown quickly from the neutral to the engaging positions, pressure being kept on the handle until the nuts are in engagement.

Regulating Pitch when Using Quick-threading Attachment. — It is important to understand the relation between the pitch of the thread to be cut and the pitch for which the regular change-gear mechanism of the lathe is set when using the quick-threading attachment shown in Figs. 4 and 5. On Hendey lathes up to and including 20 inches swing, the lead-screw has 6 threads per inch, and, as previously mentioned, the chasing sleeve of the

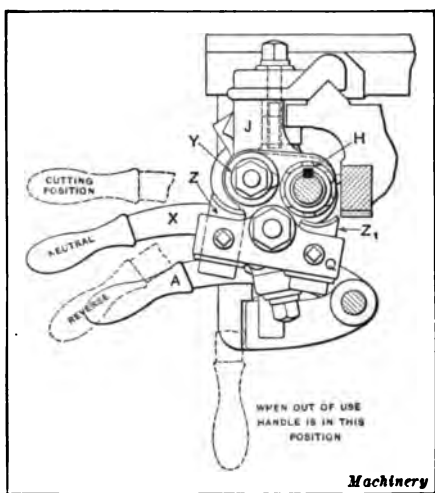

Fig. 5. End View of Quick-threading Attachment shown in Fig. 4

threading attachment revolves at the same speed as the lead-screw; therefore, it is evident that, when the lathe gear-box is set for 6 threads per inch, the pitch of the thread cut by the attachment will be the same as that of the chasing sleeve on the attachment. If the gear-box were set for 12 threads per inch, a thread of one-half the pitch of the chasing sleeve would be cut, and so on, it being possible to cut any number of threads per inch listed on the index plate of the gear-box, which is divisible by 6. For example, suppose that the chasing sleeve of the attachment has 4 threads per inch; then, with the gear-box handle set at 6 threads per inch, a 4-pitch thread will be cut; with the handle at 12, an 8-pitch thread; with the handle at 18, a 12-pitch thread; with the handle at 24, a 16-pitch thread; with the handle at 36, a 24-pitch thread, etc. When the gear-box handle is set at intermediate positions or for pitches not divisible by 6, the thread cannot be "picked up" again when the second cut is started, because the chasing sleeve is always in motion. When cutting threads which are finer than those on the chasing sleeve, it is evident that the lead-screw and attachment must rotate at a reduced speed, which reduces the speed of the return travel; therefore, it is advisable to use a chasing sleeve having a pitch as near as possible to the one that is to be cut.

Direct-acting Lead-screw. — An attachment for cutting screw threads rapidly on a lathe of the manufacturing type (see Fig. 6) is so arranged that the carriage is moved along the bed by the direct action of a short lead-screw and without the use of gearing between the lead-screw and the spindle. The lead-screw is in the form of an externally threaded sleeve and is mounted on an extension of the spindle. When a cut is being taken, the lead-screw is engaged by two segment-shaped nuts. One nut is shown at *C* and the other is on the opposite side of the lead-screw. These nuts, by traversing bracket *J* and the pull-rod *K*, transmit motion to the carriage.

In order to adjust the attachment, the carriage is located in the position it should occupy at the beginning of the cut. The right-hand carriage stop is then placed against it and fastened. The bracket *J* should be located next to the head-

stock and should be attached to pull-rod *K*, which, in turn, is secured to the carriage by means of a grip screw. With the carriage in this position, handwheel *A* is turned to the left, thus locating the two arms *B* in the position shown, which engages the nuts with the lead-screw. Stop *D* is next set so that finger *E* will contact with finger *F*. The wheel *A* is now turned to the right for disengaging the nuts from the lead-screw and the carriage is moved forward to the position it occupies at the end of

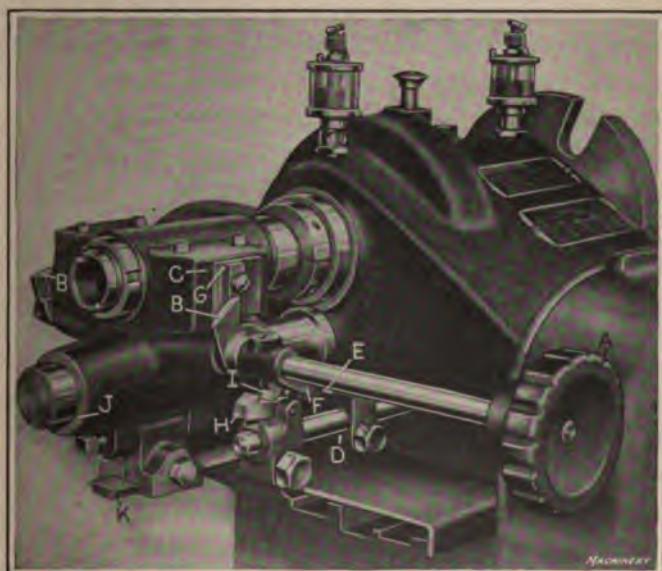

Fig. 6. Screw-cutting Attachment for Lathe of Manufacturing Type

the cut. After wheel *A* is turned to the right as far as it will go, or until the square corner of arm *B* comes into contact with the left-hand side of block *G*, trip-latch *H* is set so that it engages trip-finger *I*.

When cutting a thread the carriage is located in the starting position by the stop at the right-hand side. When the tool has been fed in for taking a cut, wheel *A* is turned to the left, thus engaging the nuts and lead-screw. The carriage moves forward until the nuts are automatically disengaged by the engagement

of finger *I* with latch *H*. The tool is then withdrawn and the carriage returned by hand to the starting position. This cycle of operations is repeated until the thread is finished. The manufacturing lathe to which this attachment is applied is made by the Porter-Cable Machine Co., Syracuse, N. Y.

Thread-chasing Attachment. — The lathes of the Fox or monitor type, which are used so extensively in the manufacture of brass fittings, have a thread-chasing attachment that affords a rapid means of cutting screw threads. The chasing attachment shown on the universal turret lathe in Figs. 7 and 8 (built by the Acme Machine Tool Co., Cincinnati, Ohio) will serve to illus-

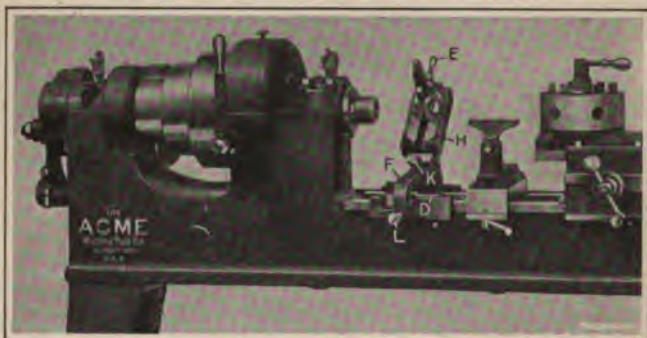

Fig. 7. Front View of Universal Turret or Monitor Lathe equipped with Thread-chasing Attachment

trate the important features common to attachments of this kind. The attachment has a round bar *A* extending along the rear of the bed. This bar is mounted in bearings so that it is free to move in an endwise direction. Attached to one end of the bar there is an arm *B* which carries the follower *G*. The follower has several arms or sections which are threaded like the segment of a nut. These segment-shaped ends have threads of different pitches to match the pitch of the thread on whatever leader *C* is being used. When the chasing attachment is in use, the follower is placed in engagement with this leader *C*, which is simply a short lead-screw and is connected through gearing with the machine spindle. As the leader rotates, an endwise movement is imparted to the chasing bar *A* and to the thread-

chasing tool which is carried by a toolpost on slide *H*, which, in turn, is supported by arm *F* attached at the rear to bar *A*. The leader is sometimes applied directly to the spindle, in which case its pitch must coincide with the pitch of the thread to be cut. Ordinarily, however, it is mounted on a shaft and is geared to the spindle in the ratio of 2 to 1, the leader revolving at one-half the spindle speed. When the leader is driven through gearing, the relation between the pitch of its thread and the pitch of the thread on the work depends upon the gear ratio. In any case where gearing is used, the leader revolves slower than the spindle in order to increase its pitch and make the

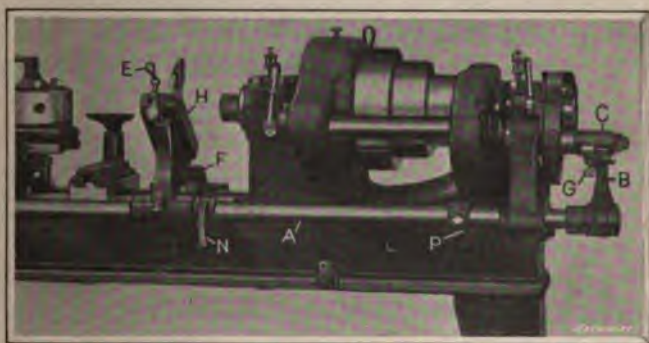

Fig. 8. Rear View of Universal Turret Lathe equipped with Thread-chasing Attachment

threads coarser and more durable. If the ratio of the gearing were 2 to 1, the pitch of the thread on the leader would be double the pitch of the thread to be cut.

The slide which carries the chasing tool is operated by crank *E*, which serves to adjust the tool in accordance with the diameter of the work. The slide is located for cutting threads on duplicate parts by a stop-screw *K*. The arm *F* has an extension which rests upon a swiveling plate *D* at the front of the bed. The upper edge of this plate is in a horizontal position, except when cutting taper threads. When arm *F* is shifted by the handle *L* at the end of the extension, the chaser bar is turned in its bearings and the follower and leader are disengaged; at the same time the tool is withdrawn from the work. The tool-slide

is prevented from swinging farther back than is necessary by a finger *N*, which engages a projection on the bed. The part to be threaded may either be held in some form of chuck, on a special arbor inserted in the spindle, or between centers, the outer center being carried in a hole in the turret. The tool-rest is clamped along bar *A* at the rear, in whatever position is necessary for locating the tool relative to the part to be threaded.

Method of Using Thread-chasing Attachment. — When an attachment of the type illustrated in Figs. 7 and 8 is in use, the tool or chaser, which is held in an inverted position, is traversed by the leader, until the end of the cut is reached; the follower is then disengaged from the leader and the tool returned for another cut, which is taken as soon as the tool is fed downward by handle *E*. These cuts may be taken rapidly and a thread finished in a surprisingly short time. The action of the chaser bar may be controlled entirely by hand or may be partly regulated by adjustable stops on bar *A* and a return spring. One method of using stops is as follows: When the chaser has moved forward the required distance, a stop on the bar makes contact with a fixed stop (which may be one of the bearings in which the shaft slides and oscillates), and the angular flanks of the leader thread force the follower out of engagement and cause the chaser or cutter to withdraw from the work. Then a coiled spring or weight acting on the bar causes it to return to the starting position, which is also regulated by an adjustable stop. This operation is repeated until the thread is finished. The method of using a stop on the machine shown in Figs. 7 and 8 is as follows: The stop *P* is set so that a spring (not shown) will return the chaser just beyond the end of the piece to be threaded, and the follower *G* is so located relative to the leader *C* that it runs off the thread of the leader when the required length of thread has been chased.

The followers of chasing attachments have teeth formed on them by means of a hob. This hob may be placed on the leader spindle temporarily, or cutting teeth may be formed at one end of the leader, thus combining the leader and hob in one unit. When there is a star-shaped follower having teeth of

several different pitches (as shown at *G*, Fig. 8), the follower is turned to locate in the working position, whichever end corresponds to the pitch of the leader being used. The leaders for thread-chasing lathes should be made of tool steel (not necessarily hardened) and the followers of a fairly soft material, such as brass.

Cutting Left-hand Threads with Chasing Attachment. —

The gearing connecting the spindle and leader of a thread-chasing attachment of the Fox type is commonly provided with an intermediate or idler gear which can be engaged in order to permit cutting left-hand threads. This idler gear is mounted on a swinging plate, and, when cutting right-hand threads, the drive is direct from the spindle gear to the gear which drives the leader. When it is necessary to cut left-hand threads, the idler is pushed over in mesh with the spindle gear, and at the same time the leader gear is disengaged from the spindle gear, so that the motion is transmitted through the idler. This reverses the motion of the leader and the movement of the chaser on the cutting stroke. It is the practice in some brass-working shops to reverse the lathe spindle for chasing left-hand threads so that the leader will continue to revolve in the same direction and the chaser will move toward the headstock of the machine when cutting a left-hand thread, the same as for a right-hand thread.

The leader driving and reversing mechanism of the universal monitor lathe built by the Dreses Machine Tool Co., Cincinnati, Ohio, is shown in Fig. 9. Gear *A* is on the main spindle and gear *B* drives the leader. For chasing right-hand screw threads, motion is transmitted directly from gear *A* to gear *B*, but for left-hand threads, lever *D* is shifted to the position shown in the illustration. The drive is then through gears *A*, *C*, and *B*. Lever *D* with its boss *F* swivels in a bearing formed in the headstock and is held in place by a set-screw and plug engaging the annular groove *N*. Lever *D* also carries the small intermediate gear *C*. Stud *E*, which supports the leader *L* and the large gear *B*, is located eccentrically in boss *F*, so that, by swinging lever *D* in one direction or the other, the direct

drive or the drive through the intermediate gear is obtained. The lugs *G* and *H* on lever *D* engage a fixed pin *K* attached to the headstock, which limits the movement of the lever and brings the gears into proper mesh.

Chasing Attachment Applied to Tapering Work. — When a chasing attachment of the type illustrated in Figs. 7 and 8 is applied to the cutting of tapering screw threads, the plate *D* is tilted at an angle, so that as arm *F* is traversed along the plate, it will be elevated, thus causing the tool to cut a tapering thread.

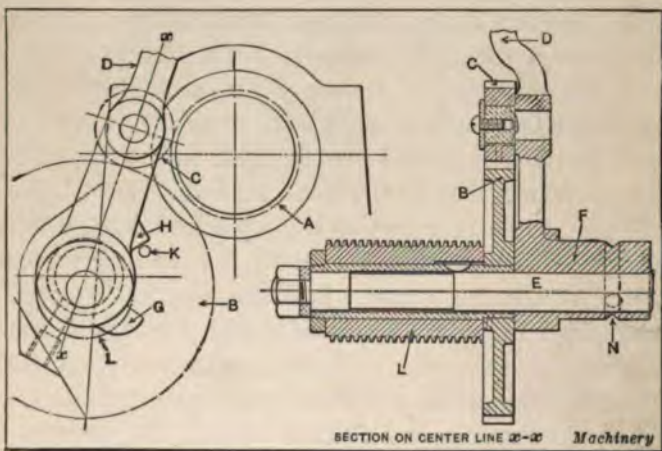

Fig. 9. Leader Driving and Reversing Mechanism

The inclination of this plate depends upon the relative lengths of the two arms of the chasing lever, the distance from the cutting teeth of the chaser to the center of bar *A* representing one arm and the distance from plate *D* to bar *A* representing the other arm.

If the arm *B* to which the follower is attached were rigidly connected to bar *A* when chasing a tapered thread, the follower would move away from the leader as the chasing tool and arm *F* were elevated by the inclined plate *D*, while traversing from the small to the large end of the tapering part being threaded. Any such movement of the follower relative to the leader would cause the chaser bar to lag behind and result in a loss in pitch, as

illustrated diagrammatically at *A* in Fig. 10. The follower, which is shown in full mesh at the starting point, would gradually move outward on the angular side of the leader thread and there would be a loss in pitch, as indicated by dimension *x*. For many classes of brass work, the error in pitch resulting from this action of the follower might be of little consequence, especially when mating parts are chased in the same way. The chasing attachment shown in Figs. 7 and 8, and many other chasing attachments now in use, has a flexible or yielding follower arm

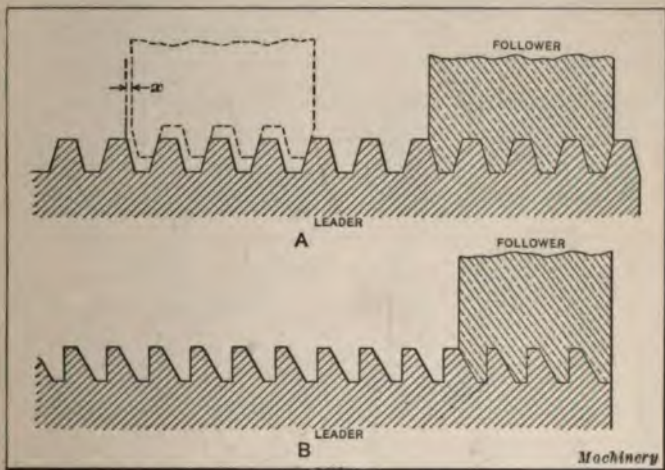

Fig. 10. (A) Action of Follower when using Rigid Follower Arm while chasing Taper Threads. (B) Form of Leader Thread intended to prevent Loss of Pitch when chasing Taper Threads

which makes it possible to chase all taper threads satisfactorily and without loss of pitch.

In order to overcome the loss of pitch due to the relative movement between a rigid follower and a parallel or straight leader, the form of leader thread illustrated at *B* in Fig. 10 has been employed. As will be seen, one side of the thread is perpendicular to the axis of the leader. One of the disadvantages of this form of thread is that the bearing between the follower teeth and the leader thread decreases as the follower moves outward, due to the difference between the helix

angles of the surfaces in contact. In some cases this difficulty has been partly overcome by allowing the follower to swivel on a stud located at right angles to the axis of the leader.

Instead of using parallel leaders for chasing taper threads, taper leaders have been employed in conjunction with an inclined plate for guiding the chasing arm. When using a taper leader, it is necessary to consider the bearing contact with the follower, which cannot be made to fit the leader thread at all points. For instance, if the follower is fitted to the small

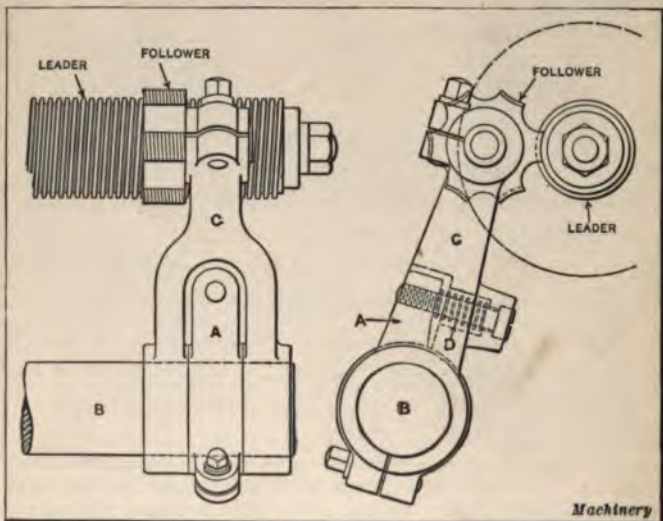

Fig. 11. Flexible or Yielding Follower Arm for Holding Follower in Contact with Straight Leader when chasing Taper Threads

end of the leader, the angle of its teeth will be greater than if it were made to fit the large end of the leader. The contact on the driving side will be at one point only on each thread or tooth, except at the small end. If the follower is fitted to the large end of a tapering leader, a better bearing will be obtained, although, in any case, a relatively small amount of follower surface will be in contact with the leader.

The difficulties previously referred to in connection with taper work have been overcome by using a flexible or spring-

supported follower arm. The yielding follower arm or holder of a Dreses universal monitor lathe is illustrated in Fig. 11.

This holder consists principally of a short lever *A*, which is clamped to the chasing bar *B*, and a yoke-shaped arm *C*, to the upper end of which the star-shaped follower is attached. Interposed between lever *A* and arm *C* is a spiral spring *D*, which bears against one side of lever *A* and rests in a pocket formed in arm *C*. When chasing a tapered thread, this spring connection holds the follower into engagement with the leader while the chasing tool travels from the large to the small end of the tapering screw thread.

If the chasing tool must run close to a shoulder, the guide plate (corresponding to plate *D*, Fig. 7) may be provided with a rather abrupt tapering shoulder for elevating the chasing tool quickly at the end of the cut.

Thread-cutting Mechanism of Gisholt Turret Lathe. — While most thread cutting in the turret lathe is done by means of taps or dies, special sizes or pitches are often required which can be cut to better advantage by using either a single-point tool or a chaser. The Gisholt turret lathe is so arranged that the carriage can be traversed by the lead-screw when a single-point tool or chaser is to be used. The lead-screw is driven through change-gears which provide for cutting thirty-two different leads or pitches, ranging from 4 to 56 threads per inch. These same gears also furnish sixty-four feed changes, the necessary reduction of movement for feeding being obtained by shifting a pull-pin which changes the ratio of the gearing through which motion is transmitted from the change-gears to the lead-screw.

The arrangement of the mechanism on the carriage which makes it possible to readily "catch the thread" each time a cut is taken is shown in Fig. 12. The view at *A* illustrates the old type, and that at *B*, the new type. These two designs differ somewhat, but are the same in principle. The lead-screw nut has a number of equally spaced notches in flange *f*, and when the carriage is being traversed by the lead-screw, the end of pull-pin *p* engages one of these notches. When the tool reaches the end of its cut, pull-pin *p* is withdrawn and

the carriage is returned by hand for taking another cut. The different notches in the lead-screw nut serve the same purpose as the graduated thread indicator on an ordinary engine lathe in that they are used for engaging the carriage and lead-screw at the right time, so that the tool will follow the original cut or thread groove. The number of notches in any lead-screw nut depends upon the lead of the lead-screw on that particular machine. The lead-screw nuts with leads of 3, 4, and 5 inches have notches so located that they represent inches of carriage travel, there being three notches in the lead-screw nut of 3-inch

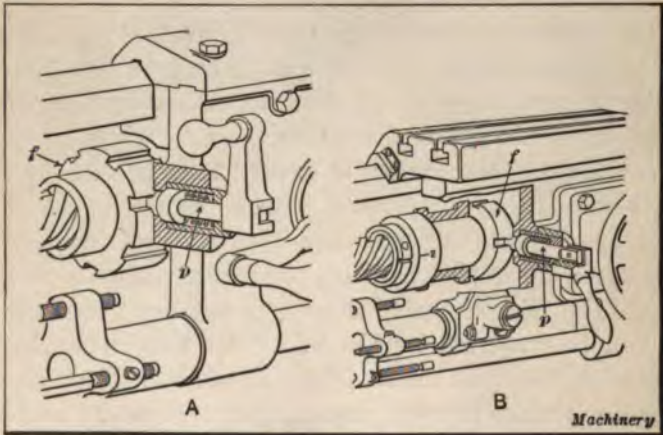

Fig. 12. Thread-cutting Mechanism of Gisholt Turret Lathe

lead, four notches in the nut of 4-inch lead, and so on. The lead-screw nuts having leads of $3\frac{1}{2}$ and $4\frac{1}{2}$ inches, which are found on two sizes of Gisholt turret lathes, have notches representing $\frac{1}{2}$ inch of carriage travel.

When cutting threads of even pitch, such as four, six, or eight threads per inch, the pull-pin p may be engaged with any notch on the lead-screw nut, regardless of the lead of the lead-screw, and the tool will follow the original cut. The reason why any notch may be engaged when the number of threads per inch is even is illustrated by the diagram *A*, Fig. 13, which shows a screw having four threads per inch. Thus, if the movement of the tool is 1 inch, as represented by posi-

tions *a* and *b*, or any whole number of inches, it will still remain in alignment with the thread groove. The alignment would also be maintained for half-inch movements, as indicated by positions *a* and *c*. If there were an odd number of threads per inch, as indicated at *B*, it would be necessary to engage the pull-pin with notches representing an inch of carriage travel, as illustrated by positions *d* and *e*. This requires two notches, or any

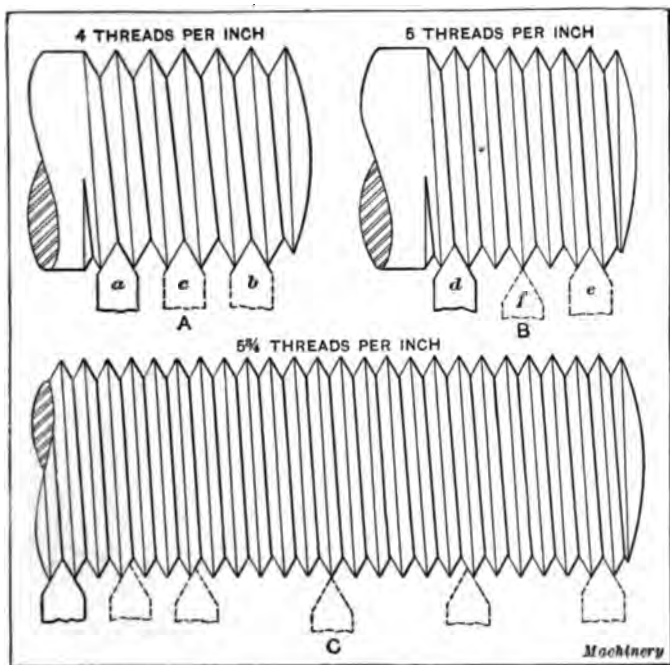
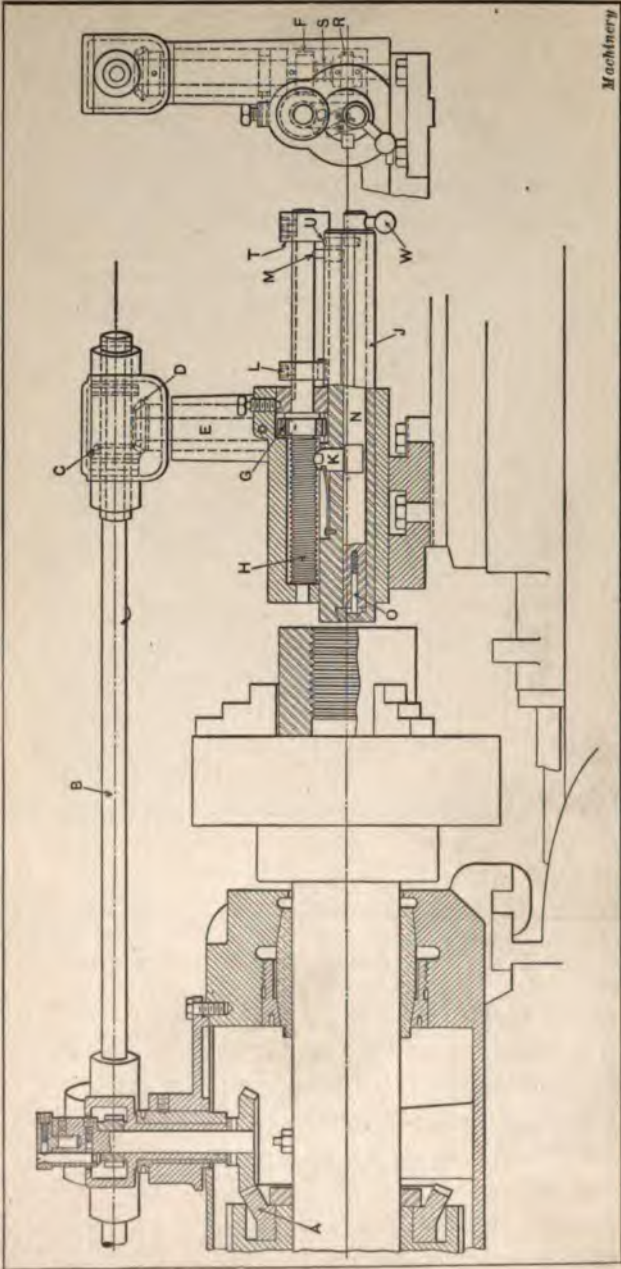

Fig. 13. Relation between Position of Tool and Screw Threads having Even, Odd, and Fractional Numbers of Threads per Inch

number evenly divided by 2 on those machines where one notch represents one-half inch of carriage travels, whereas on the other machines any notch will catch the thread. A movement equivalent to $\frac{1}{2}$ inch, $1\frac{1}{2}$ inch, etc., would locate the tool on line with the top of the thread, as illustrated at *f*. If there were $5\frac{1}{2}$ threads per inch to be cut, the pull-pin should be engaged only with notches representing two inches of travel, or 11 threads on the screw, because a movement of one inch would align the tool



Machinery

Fig. 14. Thread-chasing Attachment of Hartness Flat Turret Lathe

with the top of the thread. Diagram *C* shows a screw having $5\frac{3}{4}$ threads per inch. In this case, the movement should be equivalent to 4 inches, or 23 threads. If the notches represent inches of carriage travel, the engagement of the pull-pin with the lead-screw nut should be at points either four notches apart or any number evenly divided by 4. On the other hand, if the notches represent half inches of carriage travel, engagement at points eight notches apart, or any number evenly divided by 8, will catch the full thread. The various positions of the tools in diagram *C* clearly show why the movement must be equivalent to four inches, or some multiple of 4, in order to again locate the tool in alignment with the thread groove.

Thread-chasing Attachment of Hartness Flat Turret Lathe.

—The screw-cutting or screw-chasing attachment shown in Fig. 14 is applied to the Hartness flat turret lathe, built by the Jones & Lamson Machine Co., Springfield, Vt. This attachment is semi-automatic in operation, the cutter or chaser advancing and returning automatically while the operator regulates the depth of cut by feeding the cross-sliding headstock the required amount for each stroke of the thread-chasing tool. The attachment is driven from the bevel gear *A* on the main spindle through spiral gears and spline shaft *B*; this shaft transmits motion through bevel gears *C* and *D* to vertical shaft *E*, the lower end of which carries a spiral gear *F* that meshes with spiral gear *G*, keyed to the special lead-screw *H*. The cutter-bar *J* has a threaded plug or sectional nut *K* engaging the lead-screw. When the tool has been fed forward the required amount, the adjustable collar *L* on the extension end of the lead-screw strikes plug *M* with its projecting end, thus rocking shaft *N* and allowing nut *K* to drop down on a flat part of the shaft and out of engagement with the lead-screw. At the same time, the rocking of shaft *N*, through the eccentric pin *O*, withdraws the tool from the work. On the lower end of shaft *E* there is a spur gear *R* driven by friction resulting from the pressure of spring *S*. This spur gear is constantly in engagement with rack teeth cut on the cutter-bar *J*. As soon

as nut *K* is withdrawn, the cutter-bar is returned rapidly by the rack and pinion motion until a pin in collar *T* engages pin *U*, thus again turning shaft *N* to its former position, which reengages nut *K* with the lead-screw *H*, and then the cutting stroke is repeated. The small lever *W* may be used for disengaging the nut and withdrawing the tool by hand. With this arrangement, the main spindle rotates continuously in one direction. A separate lead-screw and nut is required for each different pitch, which must correspond to the pitch on the work. For

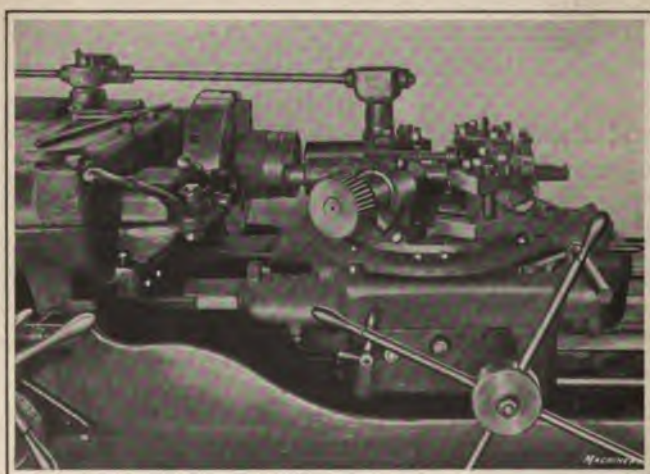

Fig. 15. Thread-chasing Attachment shown in Fig. 14 Cutting an External Thread

taper threading operations, the attachment is swiveled on its base. The chaser type of cutter, or one having several teeth, is used for U. S. standard threads, V-threads, and Whitworth threads, but single-point cutters are recommended for square and Acme threads, as well as for all threads that must extend close to a shoulder. The connections at both the headstock and turret end swivel about vertical axes and the spline transmission shaft *B* slides through the headstock connection, so that lateral feeding movements of the headstock or the indexing of the turret does not interfere with the connection to the thread-chasing attachment. This attachment is adapted for internal

and external thread-cutting operations and is shown in Fig. 15 cutting an external thread.

Thread-chasing Attachment of Acme Flat Turret Lathe.—The thread-chasing attachment of an Acme flat turret lathe, built by the Acme Machine Tool Co., Cincinnati, Ohio, is applied to the machine illustrated in Fig. 16. This chasing attachment may be used for either right- or left-hand threads on internal and external work. It is intended especially for cutting threads on parts which are either too large in diameter or required in

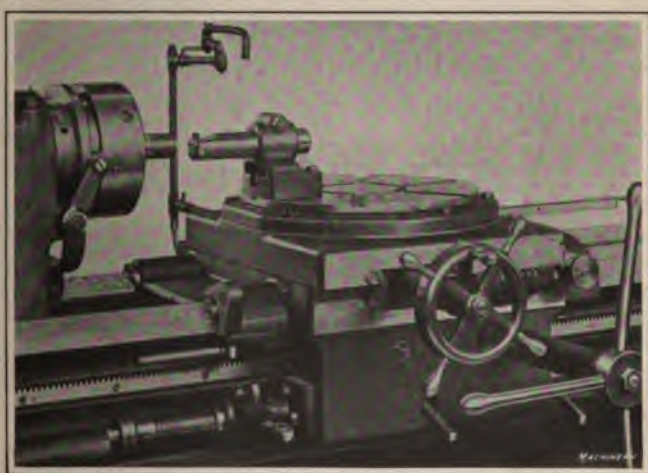

Fig. 16. Flat Turret Lathe built by Acme Machine Tool Co. equipped with Thread-chasing Attachment

too small a quantity to warrant the purchase of special taps and dies. An example of external thread cutting is shown in this particular illustration. A single-point cutter is carried by a 2-inch bar, which is rigidly held in a holder clamped onto the flat turret. The action of the carriage when cutting a thread is controlled by a leader shown on the feed-rod of the machine. The pitch of the thread which is cut corresponds to the pitch of the thread on this leader. The brass follower which engages the leader is moved into or out of engagement by the hand-lever shown. This lever is pivoted in a bracket which is bolted to the end of the carriage apron. The controlling lever is ar-

ranged to disengage automatically at the end of a cut. In order to chase left-hand threads with this attachment, it is simply necessary to shift the feed reverse lever on the gear-box at the front of the headstock.

Attachment for Cutting Threads on Drilling Machine. — A drilling machine is sometimes used for cutting internal threads with a single-point tool when the part will not swing in the lathe and the use of a tap is not practicable. A lead-screw of what-

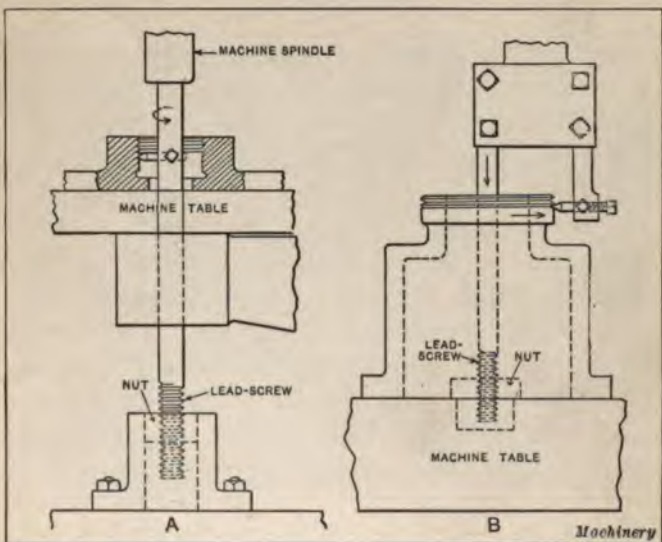

Fig. 17. (A) Method of Cutting Threads on Drilling Machine with Single-point Tool. (B) Makeshift Arrangement for Cutting Threads on Vertical Boring Mill

ever length may be needed is attached to the end of the cutter-bar, or the latter is extended to form a lead-screw as shown at A, Fig. 17. This lead-screw engages some form of nut that is bolted to the baseplate of the machine. The thread on the lead-screw corresponds, as to lead, with the thread to be cut, and, as the spindle revolves, the cutter forms a thread as it is drawn down through the work by the direct action of the lead-screw. The spindle may be returned to the starting position by reversing it, assuming that the machine has a tapping attach-

ment or other means for reversing the rotation. When performing an operation of this kind, the drill press spindle must be free to move vertically. With a makeshift arrangement of this kind intended for a special operation, the cutter would not require a special device for feeding it outward, as it could be reset for each cut without much trouble.

Thread Cutting on Vertical Boring Mill. — The vertical boring mill is used quite frequently for cutting screw threads with a single-point tool, in order to finish a part complete at one setting of the work and to avoid a second operation. Taps are often used for threading holes of small or medium size, but occasionally it is necessary to use either a single-point tool or a chaser for cutting a thread which is not standard or which is too large in diameter for tapping. When a single-point tool or chaser is employed, the cutter-bar must be traversed for controlling the lead of the thread. This traversing movement is usually obtained by means of special change-gears, which are inserted in the feeding mechanism at one end of the cross-rail. The change-gears are used to transmit motion to the cross-rail feed shaft, and they are selected with reference to the lead of the thread to be cut, the same as the change-gears of a lathe. Whatever special equipment may be needed for holding such gearing in position is supplied by most boring mill manufacturers. This is a simple and inexpensive arrangement, as motion is transmitted to the regular down-feed mechanism of the boring-bar or tool-slide through these extra gears. Some boring mill manufacturers supply this type of thread-chasing attachment for ordinary threading operations, such as the cutting of threads in large pipe flanges, etc., but for more accurate work a special lead-screw is used to control the motion of the tool-slide. A different lead-screw may be used for each pitch or lead of thread that is cut, or variations may be obtained by driving a lead-screw through change-gearing, the same as on an engine lathe.

A simple method of applying a lead-screw to a vertical boring mill is shown by diagram *B*, Fig. 17. This is not recommended for general application, but has been used to advantage when a

machine was not equipped with a regular thread-cutting mechanism and it was particularly desirable to cut the thread in the boring mill. Some form of lead-screw is attached to the end of the tool-slide, and a nut which engages the lead-screw is fastened in the central hole in the machine table. The thread tool is held preferably in a holder provided with some simple means of adjusting it when taking successive cuts. As the machine table revolves, the lead-screw and tool-slide, which should be free to move vertically, are drawn downward, thus cutting a thread corresponding to the pitch of the lead-screw.

One design of vertical boring mill has a central boring-bar with an independent rotary drive. With such a machine, a lead-screw for threading operations may be applied directly to the upper end of the bar. The split nut for engaging the lead-screw may be mounted on a stationary arm or yoke, which, in turn, is held in position by shafts or studs far enough above the end of the bar to permit moving the latter to its highest vertical position. The nuts are opened or closed by a vertical shaft having a lever at its lower end within reach of the operator. With this arrangement, the boring-bar revolves and the work remains stationary while the thread is being cut. If much thread cutting is to be done with an attachment of this kind, provision should be made for adjusting the tool radially by applying some form of independent slide at the end of the boring bar. Threading attachments of this kind are not in common use, because comparatively few boring mills are equipped with an auxiliary boring-bar, such as is found on some of the larger machines for performing high-speed boring independently of the table rotation.

CHAPTER IV

THREAD-CUTTING DIES AND THEIR GENERAL APPLICATION

MOST external screw threads are cut by means of dies, because tools of this class not only cut threads very rapidly but, when properly made, are capable of producing screws that meet most commercial requirements as to accuracy. It is impossible to enumerate all the classes of work for which dies are used; however, they are applied in general to the threading of a large percentage of the small and medium-sized screw threads, ranging from the smallest screws, bolts, and studs up to heavy screws four or five inches in diameter, or larger, in some cases. These die-cut screw threads include those of the rougher grades represented by ordinary studs, bolts, etc., and also a great deal of the more accurate work on machine parts generally.

Work of the stud and bolt class is almost invariably threaded by means of dies, but the application of dies to the better grades of screw-thread cutting depends upon conditions. For instance, dies are ordinarily used on turret lathes and semi-automatic or automatic screw machines for external threading operations, because they provide an efficient method not only of forming a screw thread, but also of doing it without removing the work from the machine. On the contrary, dies are rarely used on the engine lathe, which has its own screw-cutting mechanism and is designed primarily for a wide range of work rather than for manufacturing duplicate parts in quantity like the turret lathe and automatic screw machine. In some instances, the use of dies on the turret lathe or screw machine is not practicable, as, for example, when there is a shoulder between the surface to be threaded and the turret.

While there is no well-defined line showing just where the practical application of dies ends, there are certain limiting

factors which should be considered. In general, as the pitch of the thread and its diameter increase beyond certain limits, the use of dies decreases. Dies may be employed for cutting threads of coarse pitch, but, ordinarily, the lathe or a thread milling machine is used in preference. Whether or not a die could be used to advantage might depend upon the type of machine employed for the other operations, such as turning, etc., and the number of pieces to be threaded or the degree of accuracy required. In the manufacture of pipe, dies are used for cutting the threads even on the large sizes, because they provide a rapid means of doing the work and the pitches of the threads are fine in proportion to their diameter. As the large dies used for pipe threading or other operations are quite costly, they can only be employed to advantage when the quantity of work warrants the necessary investment.

Dies are efficient as a means of cutting screw threads, because they usually finish the tread complete in one cut, although two passes or cuts are desirable for certain classes of work, some dies being arranged for taking a light finishing cut. When cutting threads of coarse pitch, considerable metal is removed in a short time, especially when a single cut is taken, and although these heavy cuts may be distributed between three or four teeth at the throat of the die, the difficulty of obtaining smooth, accurate screw threads increases for the larger pitches. Dies may be used for pitches up to one-quarter or one-third inch, or even larger, but die threading operations of this kind are not common. When dies are used for cutting screws of coarse pitch and of relatively small diameter, the torsional or twisting strain on the work and the resulting effect on the accuracy of the screw may be so great that the use of a lathe or thread milling machine is preferable, if not necessary.

When making any comparison on the basis of accuracy between screw threads cut with dies or by means of a lathe or thread milling machine, it is important to remember that there are "dies and dies." In general, a well-constructed lathe or thread milling machine will cut a thread that is more accurate as to form and lead than a high-grade die, for the following rea-

sons: In the first place, a carefully ground single-point tool or single type milling cutter is more accurate than a multiple-point die chaser or cutting edge, which must be correct both as to the form of each tooth and the pitch of the teeth; second, a die which is self-leading and not positively controlled by a lead-screw is less likely to produce a thread of accurate lead than a single-point tool or a rotating milling cutter that derives its motion directly from an accurate screw. There is a difference, however, in the self-leading qualities of different dies. Some of the important causes of inaccuracy in the lead of die-cut threads will be considered later. The difference in accuracy between the best grade of die work and the product of the lathe or thread milling machine is usually so small as to be negligible for most commercial work, which, in conjunction with the speed of dies as a means of screw cutting, accounts for the extensive application of dies in all machine building plants.

Types of Non-opening Dies. — Dies may be divided into two general classes, namely, those that are removed from the screw thread by being backed off or unscrewed, and those that may be opened so that the cutting edges clear the screw thread, thus permitting the die to be removed by traversing it over the work in a lengthwise direction. The non-opening dies are capable in some cases of hand adjustment, but the object of this adjustment is to vary the size of the die, so far as machine threading operations are concerned. There are four types of non-opening dies in common use, which may be designated as (1) solid dies, or those that are rigid and incapable of any adjustment for varying the diameter; (2) flexible dies, or those that are split in one or more places and may be adjusted to some extent by compressing or expanding; (3) sectional dies, or those formed of two adjustable sections; (4) rigid adjustable dies of the chaser type, having inserted chasers that may be adjusted radially within certain limits either for maintaining a standard size or for varying the size slightly.

A common form of solid die is shown at *A*, Fig. 1. This form is used for some bolt and pipe threading operations and for the rougher classes of screw cutting. The accuracy of the die is

likely to be impaired considerably by hardening, and there is no means of reducing the diameter as it gradually increases on account of wear. Most solid dies of the rigid class are square on the outside, although some are round or of hexagonal shape. The latter are similar to a nut except that they have flutes on the inside to form cutting teeth and are made of hardened steel. Dies of this kind are used principally for repair work, as they are easily turned with a wrench and are convenient for truing or recutting battered threads.

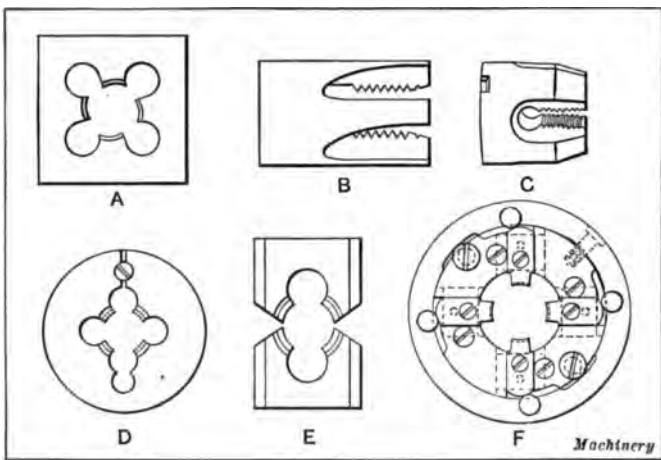

Fig. 1. Different Types of Threading Dies

The split dies, or those having enough flexibility to permit adjustment, are made in different shapes, the three common forms being the spring screw die shown at *B*, the "acorn" die *C*, and the round split die *D*, which is sometimes known as a "button" die. A great many spring screw threading dies are used on automatic screw machines for cutting the smaller sizes of screws. The die has four projections or prongs on which the cutting edges are formed. These prongs are quite flexible and must be held in position when the die is in use by some form of external ring or clamp. Many of these clamping rings are split on one side, and the split ends are joined by a screw which provides adjustment for closing in the cutting edges to the required size.

This type of clamp is objectionable in that it does not compress the different prongs uniformly, so that the work of cutting the thread is not properly distributed between the cutting edges. One method of overcoming this difficulty is to use a solid ring that is slightly tapering on the inside to fit a corresponding taper on the outer surfaces of the die prongs.

The collet style of holder for spring screw dies is a further improvement, as it is in the form of an external sleeve completely surrounding the die, and not only holds it rigidly, but provides a convenient means of uniform adjustment for variations in size. The teeth of these dies may be cut with either a straight hob or from the back with a hob that is slightly tapering. When a straight hob is used, it is a few thousandths over size, the amount depending upon the pitch of the thread; the prongs of the die are afterward forced in to the correct size by the clamp collar or chuck. This adjustment produces a slight inaccuracy in the thread, and, for that reason, it is preferable to use a tapering hob in order to obtain the necessary clearance, the die being cut to the correct size at the point and not over size, as when a straight hob is used. This back taper varies from 0.005 to 0.010 inch per inch for iron and steel, and from 0.008 to 0.015 inch per inch for dies employed for cutting threads on brass. One of the great advantages of the spring screw die as compared with the round split form shown at *D* is that the radial cutting edges can easily be reground when they become dull by using an ordinary dished wheel, the beveled edge of which is inserted in the flutes of the die. With the round split form, a special grinding wheel is required.

The lands or cutting ends of the acorn die *C* are shorter and wider than those of a spring die, which increases their strength against torsional or twisting strains. The part of each land or prong just back of the cutting teeth is made comparatively thin to give the necessary flexibility for radial adjustment. The form of holder used in connection with this die (as manufactured by the Greenfield Tap & Die Corporation, Greenfield, Mass.) is illustrated in Fig. 2. The die *D* is contained within an adjustable cap *A*, which is screwed onto section *B* of the

die-holder. The outer end of each die prong is beveled to fit a corresponding conical surface on the inside of the adjusting cap *A*. The base of the die, which is ground true, bears against the end of the floating part *B* of the die-holder and has notches which engage short driving pins. The connection between part *B* and shank *C* is obtained through a cross-pin *E*, which engages the slots shown in the illustration. This arrangement provides a certain amount of floating movement. Radial adjustment of the lands for varying the size of the die is obtained by simply turning the adjustable cap *A* in one direction or the other after loosening the locking nut. The adjustment derived in this way, by means of the internal conical surface

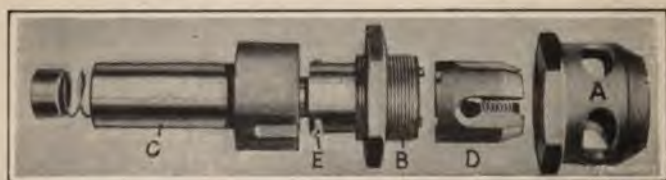

Fig. 2. Acorn Die and Die-holder

referred to, serves to move each of the four lands an equal amount radially, so that the work of cutting a screw thread is evenly distributed. The acorn die, like a spring die, may readily be resharpened on the radial faces, the grinding being done in the flute, the same as with a spring die.

Round split or button dies (one form of which is shown at *D*, Fig. 1) are used principally on turret lathes and on hand and automatic screw machines; they are applied to the same general classes of work as spring screw threading dies. The button dies are more rigid than the spring dies, if the latter are adjusted by the usual ring or clamp, but, as previously mentioned, they are not so easily sharpened on the radial cutting faces. The initial cost of the button die, however, is less than that of a spring die and the former is not distorted as much in hardening.

The sectional type of die formed of two separate parts (*E*, Fig. 1) is extensively used in die-stocks for hand threading operations on bolts, pipe, etc., and also in some power-driven

screw-cutting machines. The outside shape of these dies varies. The form shown has sides with a double bevel to give the two die sections a tight grip in the holder and permit reversing the position of the die for cutting close to a shoulder. Some dies of the two-piece form are round and are used in preference to the kind shown at *D*, which is split on one side only. The advantages claimed for this type are that it does not lose its shape the same as a die which springs together on one side only, and it can be more easily ground.

The rigid adjustable die of the chaser type (*F*, Fig. 1) provides a convenient means of adjusting the die either to compensate for the wear of the chasers and maintain a standard size or to vary the diameter slightly from the standard. This general type has several advantages when applied to operations for which it is especially adapted. For cutting comparatively large screw threads, the chaser type of die is preferable to a solid split or spring die, partly because it is capable of more accurate work. The one-piece die is always subject to distortion in hardening, especially when made in large sizes. The use of inserted chasers is also an advantage, because a practically new die may be obtained by inserting a new set of chasers, when, as a result of repeated grinding and wear, this becomes necessary; the body of the die may be used permanently. Dies of the adjustable chaser type may be used in preference to the automatic or self-opening class (to be described later) for cutting screw threads that are so short that the time saved by the opening dies is too small to offset the difference in cost. The adjustable chaser design, in general, is also more rigid than the self-opening die and better adapted for taking heavy cuts on threads of coarse pitch when the thread is to be finished by a single cut. The construction of these dies varies considerably. The particular design shown at *F* (the "Namco") has four chasers, which are held firmly over plates in the body by screws and dowel-pins. They are supported laterally or at the sides by hardened eccentric binding screws and are backed up at the ends by hardened pins carried by a heavy adjusting ring. A loose or tight fit may be obtained with a set of chasers by means

of an adjusting screw which changes the position of the adjusting ring and pins relative to the oval-backed chasers.

Removal of Non-opening Dies from Work. — After a screw thread has been cut with a non-opening die, the latter is removed by unscrewing or backing it off the threaded section, unless, as is sometimes the case, the part being threaded passes clear through the die. The latter method is sometimes followed when a vertical-spindle machine like a drill press is used for threading plugs or other parts by screwing them down through a die attached to the table; the finished work then simply falls through the die. The same method has been employed in threading taps. It is especially applicable when there is a square end on the work, or opening, to provide a convenient means of driving by simply engaging the parts with a socket or other form of driver on the spindle that readily releases after the work has passed through the die. While this method of cutting screw threads has been utilized to some extent, in most cases it is necessary to back off a non-opening die, and this may be done in three different ways: (1) the rotation of the work may be reversed after the thread is cut; (2) the die itself may be reversed, thus unscrewing it from the threaded part; (3) the die may be revolved in the same direction as the work, but at a somewhat slower rate of speed while cutting the thread and then at a faster rate so that the die backs off the threaded part while it still continues to revolve in the same direction as the part being operated upon. This third method is employed on some automatic screw machines.

Application of Self-opening Dies. — The automatic or self-opening type of die represents one of the most important developments in thread-cutting tools. There are two serious objections to the non-opening die: One is that time is wasted while the die is backing off the threaded part. The other and often more serious objection, especially when threading tough material, is that the threads are frequently marred, if not spoiled entirely, by the backward movement of the die. This roughing or tearing of the thread is due to the fact that, when either the die or the work reverses, there are chips left in front of the

cutting edges, especially at the throat of the die; consequently, as the die moves back, these chips or others previously removed often become wedged between the lands of the die and the screw and roughen the thread or tear it as the die is being removed. Trouble of this kind may often be greatly reduced or practically eliminated by using dies having a minimum amount of relief. The roughness of the thread may also be due primarily to other causes. For instance, some grades of soft "stringy" steel are difficult to thread smoothly. In such a case, the only remedy is to use a steel higher in carbon or, if a good grade of material is not necessary, a steel higher in phosphorus and sulphur. The roughness of a thread may be, and often is, due to the use of die chasers which are not properly made or ground. Unscrewing the die, however, has caused much trouble, and defects from this source may be avoided by the use of self-opening dies. The latter may also increase the speed of thread-cutting operations 30 or 40 per cent, by reason of the rapid removal of the self-opening type after the thread is cut. The additional complication necessary in a self-opening die means a higher initial cost which is sometimes to be considered when the amount of work is relatively small.

An automatic die is, as a general proposition, less rigid than a non-opening die such as the inserted-chaser type, especially after the parts have become worn. It is for this reason that some self-opening dies will not cut a satisfactory short thread, especially if the length of the thread is about equal to the width of the die chasers. The chasers spring outward somewhat at the beginning of the cut and make the thread tapering. This error may be so small as to be negligible when a good die is used, and, in any case, screws having a length equal to several times the die-chaser width will be cut straight except for a few threads at the beginning and end of the screw where there may be an appreciable amount of taper. Another difficulty that has been experienced with some self-opening dies is in the accumulation of chips in the die-head, which interferes with the action of the movable members and increases the amount of wear. Much has been accomplished, however, in the design of self-

opening dies toward keeping the die-head free from chips that impair its effectiveness and also in rigidly supporting the chasers so that outward radial thrusts are taken directly by solid parts of the die. The relative merits of self-opening dies and the solid or non-opening type may depend upon the length of thread to be cut, the type of machine, its reversing speed, and the number of parts to be threaded.

Types of Self-opening Dies. — The different designs of automatic or self-opening dies differ principally in regard to the

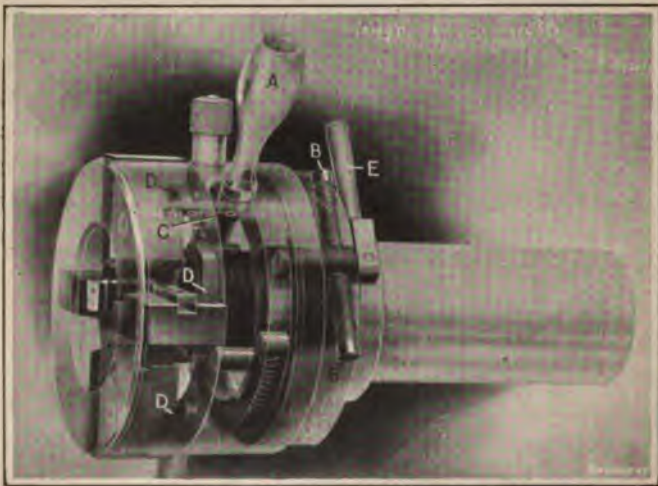

Fig. 3. Geometric Style D Self-opening Die-head

mechanism for opening the die chasers at the completion of a cut, the method of closing the chasers to the cutting position after removing the die, and the method of supporting the chasers against radial thrusts. Self-opening dies, in general, are formed of two main sections. One section, which includes the shank and inner part of the die body, is attached to the turret, spindle, or other part of the machine. These two main sections have a certain relative motion for opening the die or releasing the chasers from the work and for closing the chasers to the working position. This motion for operating the die may either be parallel to the axis of the die, rotary, or helical. The radial

motion of the chasers for opening or closing the die is commonly derived or controlled either from cam surfaces or the conical surface of a sleeve in contact with the chasers.

The three general methods for opening dies of this class automatically are by stopping the travel of the turret at a predetermined point; by the engagement of an outside tripping finger, latch, or lever on the die-head with a fixed stop or plate; and by the engagement of the end of the work with a tripping plate located inside the die. Most self-opening dies are of the non-

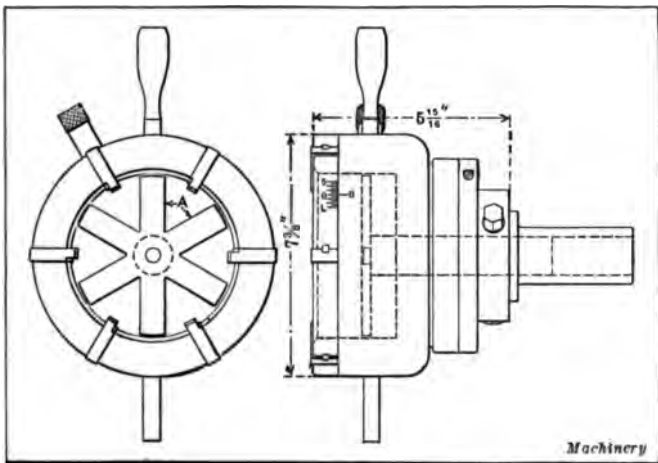

Fig. 4. Self-opening Die-head of Internal Trip Type

revolving type, the die remaining stationary while the part to be threaded rotates. Dies of this class commonly have a hand-lever for opening or closing them. Some dies of the automatic class are designed to be revolved. Several commercial designs of self-opening dies will be described to illustrate the variations in construction and methods of operation.

Geometric Self-opening Dies. — The standard design of Geometric self-opening and adjustable die (style D) shown in Fig. 3 is intended for use on hand-operated turret lathes and automatic screw machines. This die, made by the Geometric Tool Co., New Haven, Conn., is so arranged that it opens automatically as soon as the travel of the shank section of the

die-head is retarded. When used on the turret lathe, the stop-screw or rod of the turret-slide may be set to stop the movement of the turret when the required length of thread has been cut. If desired, the die can be opened at any intermediate point by simply holding back on the lever for operating the turret-slide. The die chasers are closed to the working position after being opened, by handle *A* projecting from the side. The die may also be closed automatically by screwing a pin into a threaded hole opposite this handle and attaching a stop to the

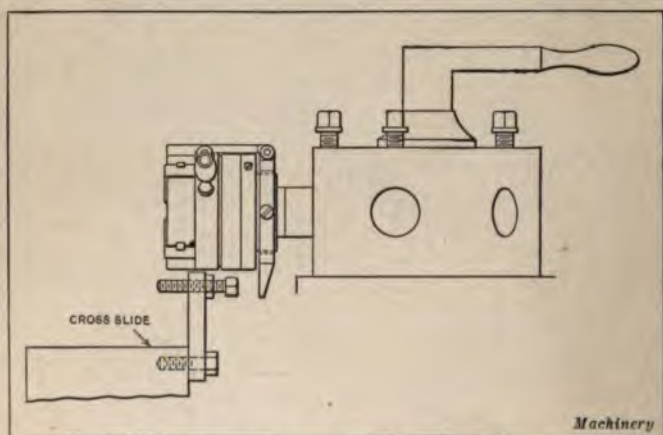

Fig. 5. Self-opening Die-head of Outside Lever Trip Type and Adjustable Stop for Controlling Point at which Die trips or opens

rear edge of the turret-slide in such a position that it will engage the pin as the turret revolves. Slight variations in diameter (indicated by graduations at *C*) to secure a tight or loose fitting screw may be obtained by adjusting screws *B*. The radial movements of the die chasers for opening or closing the die are derived from cams *D* which engage slots in the chasers on the rear side. The chasers are held on splines at one side of the opening in which they are a close fit to prevent tilting due to the cutting strain. This style of die is made in sizes ranging from $\frac{1}{8}$ to $4\frac{1}{2}$ inches. The sizes over and including $\frac{3}{4}$ inch have an attachment which permits taking roughing and finishing cuts. When the small lever *E* is turned to a position opposite

that shown in the illustration, the chasers are all moved outward 0.01 inch ready for the roughing cut. Returning this lever to the position shown closes and locks the chasers for the finishing cut.

A style C Geometric die of the inside trip type is shown in Fig. 4. This die has an internal adjustable gage or stop *A* which comes in contact with the end of the work, thus auto-

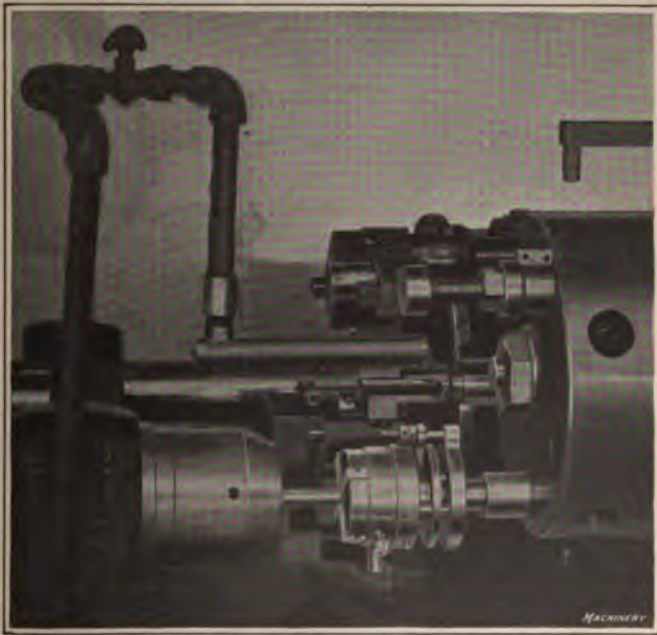

Fig. 6. Geometric Style DD Self-opening Die-head on a Cleveland Automatic

matically opening the chasers. This type is preferable to the "pull" type (which trips after the turret-slide stops) for certain classes of work and for some machines, as, for example, where turret stop-screws or rods are not provided for every turret hole. Fig. 5 shows a style C Geometric die of the outside lever trip type. A fixed stop is attached to the cross-slide and it is provided with an adjustable screw for varying the point at which engagement with the tripping lever of the die occurs.

The outside lever trip type is recommended for cutting short threads of fine pitch, because the chasers are relieved of all strain when tripping.

A third style of Geometric die (style DD) is shown in Fig. 6 applied to a Cleveland automatic screw machine. This die was designed especially for use on the turret of the Cleveland machine, but it can be applied to other automatic or semi-automatic machines in which the operating requirements are practically the same. The die-head is supported by a spring

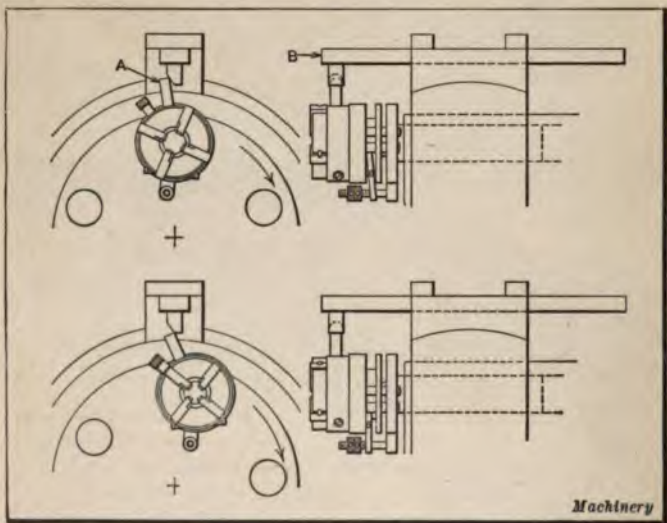

Fig. 7. Closing Attachment for Self-opening Die-heads applied to a Cleveland Automatic

mechanism between the head and shank which permits the chasers to align themselves with the work and compensate for any slight inaccuracy in turret adjustment. This floating connection also permits a certain amount of longitudinal movement independent of the motion of the turret-slide so that the die is free to follow its own lead. After the turret-slide stops its forward movement, the die-head has a slight independent movement which brings the lock-nuts seen in the side of the die-head in contact with a hinged plate. The movement of this plate releases the locking bolt and allows the chasers to

open or move outward. The point at which the die opens may be varied slightly by adjusting these lock-nuts. The illustration shows the die at the point where the tripping mechanism is about to operate, the lock-nut having come into contact with the tripping plate.

The arrangement for closing the die-head automatically is illustrated in Fig. 7. A closing pin *A* is attached to the die-head, and mounted above the turret there

is a closing bar *B* having a beveled pin which projects downward. After a thread is cut by the die, the latter is carried



Fig. 8. "Namco" Self-opening Die-head of Non-revolving Type



Fig. 9. "Namco" Self-opening Die-head on a Cleveland Automatic, showing Closing Device

around as the turret indexes until the closing bar comes into contact with the pin on the die. The upper view shows the

die-head just at the point of closing and the lower view illustrates how the die is turned part of a revolution for closing as the turret indexes.

“Namco” Self-opening Dies. — A “Namco” self-opening die of the non-revolving type is shown in Fig. 8, and applied to a Cleveland automatic screw machine in Fig. 9. This is another die of the type that opens when the turret-slide reaches the end of its travel. When the forward movement of the slide is discontinued, further rotation of the screw thread draws the die-head forward, thus releasing the chasers from their bearing on the

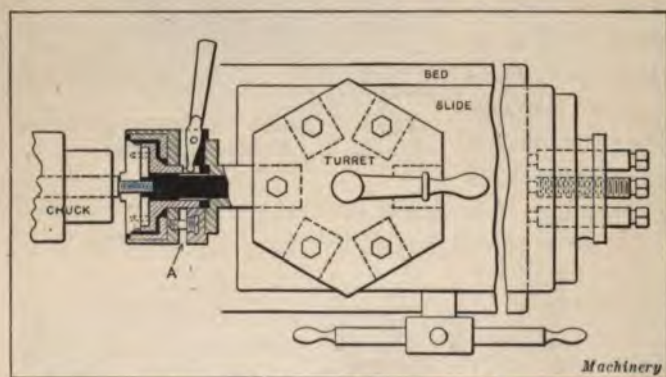

Fig. 10. Diagram illustrating Method of adjusting Turret-slide Stop for a “Namco” Self-opening Die-head

cam-ring arms and allowing them to spring open. The die is closed by the lever seen projecting from the side which serves to draw the body back into the hood, thus bringing the chasers into contact with the cam-ring arms. Whatever variations in diameter may be required are obtained by a sensitive adjusting screw in the side of the die-head. The hand-lever may be operated automatically by the rotation of the turret, as when the die is used on an automatic screw machine. The closing device shown in Fig. 9 consists of a projecting plate or arm having an inclined edge over which the closing lever slides as the die is indexed past this point. The form and location of this closing attachment varies more or less for different machines.

When the die is used on the turret lathe, the general method

of adjusting the turret-slide stop for controlling the operation of the die is as illustrated by the plan view, Fig. 10. After the die is attached to the turret, the first thread is cut to the required length and the machine stopped with the die chasers still engaged with the thread, the chasers being closed. The turret-slide stop is next adjusted until the slide moves backward sufficiently to take up the lost motion or longitudinal float at *A* in the die-head, and the die chasers spring open. Another trial screw thread is then cut, and if the length of the thread must be exact, a slight further adjustment may be necessary. The method of arrest-

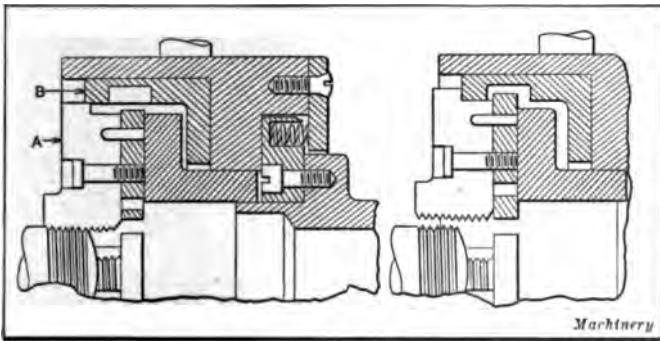

Fig. 11. Sectional Views of No. 11-12 Series "Namco" Self-opening Die-head showing Arrangement for Obtaining Instantaneous Opening Action

ing the feeding movement of the turret varies on different machines.

The "Namco" die-heads do not have a cover or plate in front, but are left open; one reason for this construction is to permit a free flow of oil through the die-head to flush or wash out the chips so that the die will be self-cleaning. Some "Namco" die-heads (the No. 11-22 series) are designed especially for cutting very short threads or those of ordinary lengths right up to a shoulder if necessary. The die-head is designed to open the chasers instantaneously at a given point. The top or outer ends of the chasers are not beveled as in the dies previously referred to, but have square shoulders instead, as shown by the sectional view, Fig. 11. The bearing arms *B* of the cam ring rest on the top of these

shoulders until the chasers *A* are pulled forward at the end of the cut by the action of the screw thread; the arms of the cam ring then drop down into the lower shoulders, as shown by the view to the right, thus allowing the chasers to fly outward instantly, in order to prevent interference with a shoulder on the work.

The revolving type of "Namco" self-opening dies is designed for use on the Acme automatic multiple-spindle screw machine.

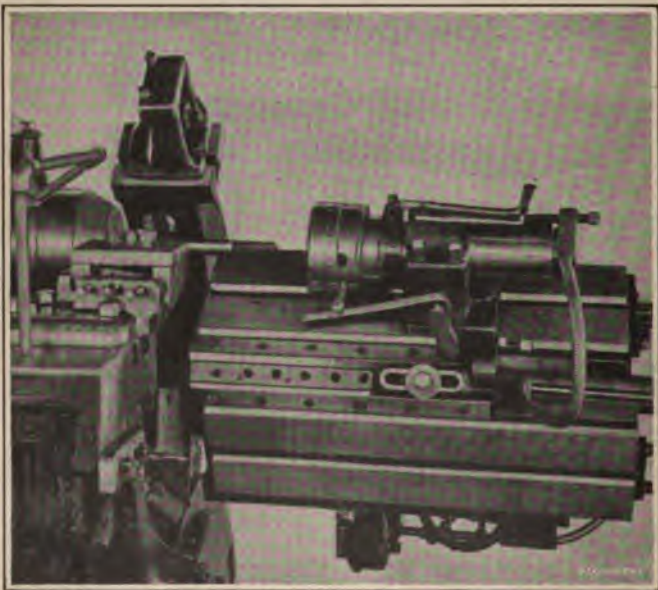

Fig. 12. Hartness Self-opening Die-head applied to a Gridley Automatic

on bolt and stud threaders, and other machines in which the work is held stationary while the die is revolved, or in cases where both the work and die rotate. The opening and closing of the chasers is effected by the longitudinal motion of the hood relative to the body of the die, the same as with the designs previously referred to. The floating style of revolving die-head is designed for threading parts that are not finished from the bar at one setting but are chucked either by hand or from a magazine for the threading operation. This floating mechanism

compensates for any variation in alignment between the work and die-spindle. The "Namco" dies are made by the National Acme Co., Cleveland, Ohio.

Hartness Automatic Die.—A Hartness automatic or self-opening die is shown applied to a Gridley automatic in Fig. 12, and in section in Fig. 13. The construction of these dies varies somewhat for different sizes, although they operate on the same general principle. The description applies to the No. 4 size shown in Fig. 13. The die body is held to the shank by screws

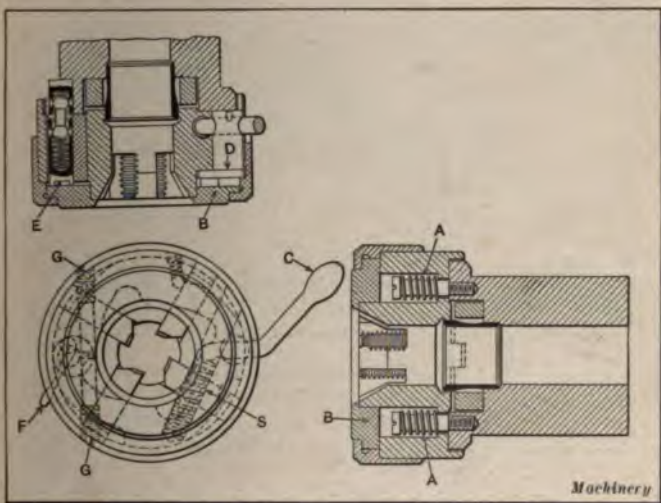

Fig. 13. Mechanism of Hartness No. 4 Automatic or Self-opening Die-head

A and the springs around them. An equalizing collar provides the driving connection between the body and the shank and allows the body with its chasers to float and thus center itself relative to the action of the work. The chasers are held in position in radial slots in the body and their movements are controlled by cam ring B. By throwing over the locking lever C against the pressure of the main springs, the cam crank D and the cam ring are turned, thus closing the chasers. The cam ring is held in the closed position by the latch-pin E, which has two engaging surfaces for locking the cam ring. One of these

surfaces is regularly used for taking the finishing cut. If the material is hard or the pitch coarse enough to require two cuts, the roughing handle *F* is thrown over, so that another surface on the latch-pin is utilized and holds the chasers in position for the roughing cut. After roughing out the screw thread, the chasers are set for the finishing cut by simply throwing handle *F* back to its original position. The latch-pin is contained in an eccentric sleeve, which may be turned to vary the position of the cam ring for adjusting the radial location of the chasers and the

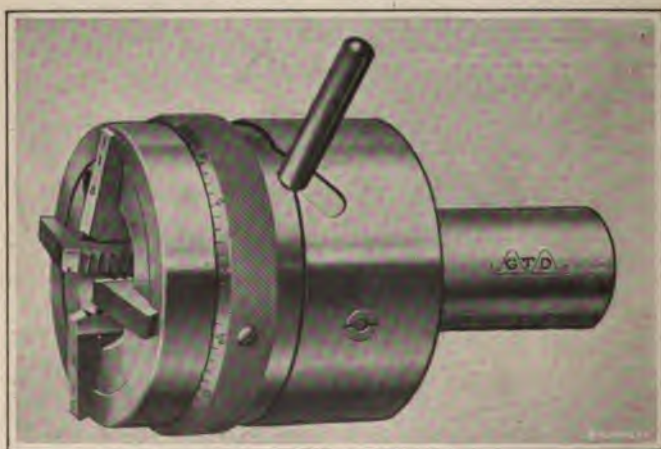

Fig. 14. Wells Self-opening Die-head of Model B Pull-trip Type

finished size of the work. The size-adjusting screws *G* are used for making this change. The two cuts (roughing and finishing) are seldom required for threads smaller than one inch in diameter and 12 pitch, but are intended to be used for coarse pitches and on materials that are especially hard and tough. The largest of the Hartness dies (the No. 9) has three separate adjustments, so that two roughing cuts and a finishing cut may be taken if necessary, without disturbing the adjustment for the final or finishing size. Fig. 12 illustrates one method of closing the die automatically. A pin projecting from the side of the die engages the inclined plate shown. This self-closing feature varies on different makes of machines, so far as its exact arrangement

is concerned. The automatic opening of the die occurs whenever the feeding movement of the tool-slide discontinues. The die-head travels forward a short distance before opening, after the tool-slide has stopped. These dies are manufactured by the Jones & Lamson Machine Co., Springfield, Vt.

Wells Self-opening Dies.—The Wells self-opening die, manufactured by the Greenfield Tap & Die Corporation, Greenfield, Mass., is made in three models. Model B, intended for general use on turret lathes, automatic screw machines, etc.,

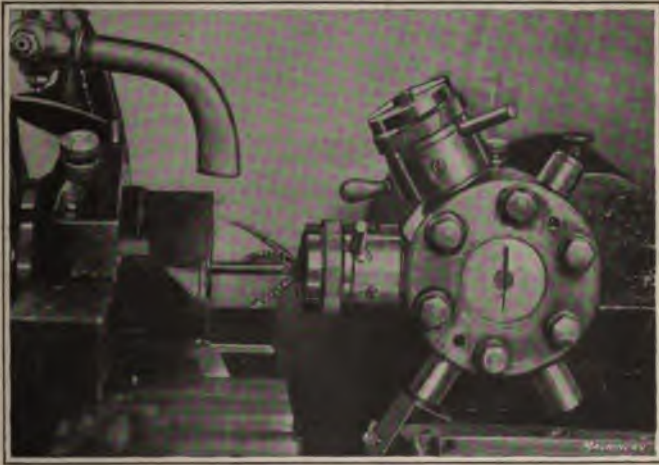

Fig. 15. Two Wells Self-opening Die-heads for Taking Roughing and Finishing Cuts on a Brown & Sharpe Automatic Screw Machine

is shown in Fig. 14. This model is a pull-trip design, the chasers opening automatically after the advancing movement of the turret-slide is discontinued. The chasers are held in slots in the body of the die, and are supported near the rear end by hinge pins, which serve as fulcrums for the opening and closing action. A spring-actuated plunger bears against the short rear ends of the chasers, forcing the front ends of the chasers outward against an external sleeve or shell. This shell has a beveled surface on the inside which bears against a corresponding bevel on the back of the chasers and furnishes a firm backing or sup-

port directly back of the cutting teeth. This outer shell slides in a lengthwise direction on the inner body of the die, permitting the chasers to open as it slides back and closing them as it is pushed forward. In action, as soon as the turret-slide stops, the die is automatically tripped by a specially shaped shoulder on the trip-screw engaging with the latch. The opening action is as described in the preceding. The die is closed by the handle or pin, which projects from the side, coming in con-

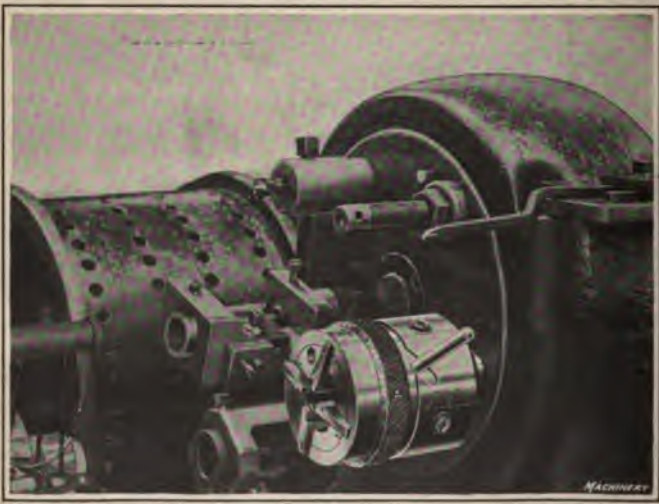

Fig. 16. Wells Self-opening Die-head applied to a Cleveland Automatic

tact with a stop, where it is latched in position ready for the next cut. Slight diameter adjustments for making the thread either larger or smaller than the standard diameter are made by turning a knurled and graduated ring.

Fig. 15 illustrates two Model B dies applied to a Brown & Sharpe automatic screw machine. This is particularly fine work where a specially finished thread is desired; one of the dies is used to take the roughing cut and the other the finishing cut. These dies are closed automatically by the rotation of the turret, the closing handles on the dies coming into contact with a stationary spring finger or other form of fixed stop.

The operation of the same type of die on a Cleveland automatic is shown in Fig. 16. The die just described has in some measure replaced the Model V, which is shown on a drilling machine in Fig. 17. This is not a typical application, however, as this design is used more generally on hand-operated screw machines or turret lathes. This is the simplest form of any



Fig. 17. Thread Cutting on a Drilling Machine with Stationary Self-opening Die.

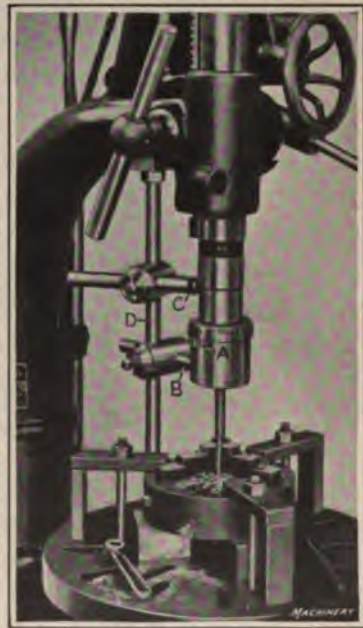

Fig. 18. Drilling Machine equipped with Revolving Type of Self-opening Die.

of the three models. It is opened automatically by the engagement of a latch projecting from the face of the die with the work-holding chuck or some form of stop that may be attached to the machine. The hand-lever *A* on the die is intended for operating it when setting up the machine. A twist of the cross-bar *B* at the top of the lever releases the latch, thus permitting the die to open.

Drilling machines are often used for thread cutting when

this is the only operation and it is not convenient to use another type of machine. The revolving or "rim trip" type of Wells self-opening die, Model T, is intended for application on such machines as drill presses, bolt cutters, multiple-spindle screw machines, etc. This die, which is shown applied to a vertical-spindle drilling machine in Fig. 18, is tripped or opened by a ball-shaped latch *A*, which projects through an opening in the side of the die shell or body. This model is closed by a yoke pushing the outer shell forward, or it can be closed by a stop bearing upon one side only. As arranged in Fig. 18, stop

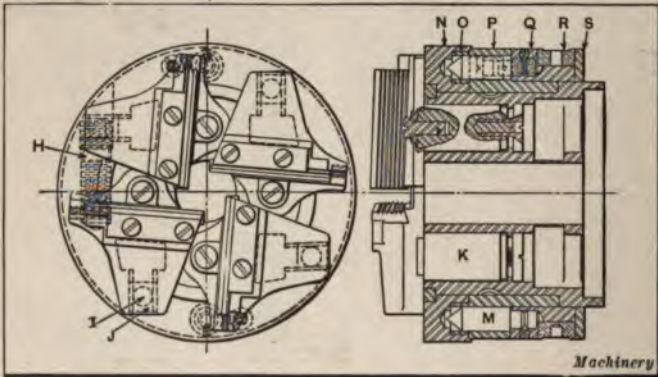

Fig. 19. Landis Rotary Die-head

B trips the die when latch *A* has descended far enough to strike it. When the spindle is raised, stop *C*, which carries a roller at its end, engages the upper end of the sliding shell and holds it stationary while the die body is pulled up far enough for the trip latch to drop into place. These stops may be adjusted on the vertical rod *D* for varying the tripping and closing points in accordance with the length of screw thread. This die is adjusted by turning a small screw in the die face, which changes the position of the stop for the tripping latch. The chasers are the same as those in the other models, and their position in the body and opening and closing motion are exactly the same. Models B and V are equipped with or without a floating shank, permitting the die to advance upon the work according to the

lead of the chasers and independently of the travel of the turret-slide.

Landis Self-opening or Rotary Die-head.—The die-head illustrated in Fig. 19 differs from any of those previously referred to partly in that the chasers are set in a tangential position relative to the work instead of in a radial position. This particular design is designated by the manufacturer (Landis Machine Co., Inc., Waynesboro, Pa.) as the "rotary die-head," and has been used extensively on threading machines of the bolt-cutter type.

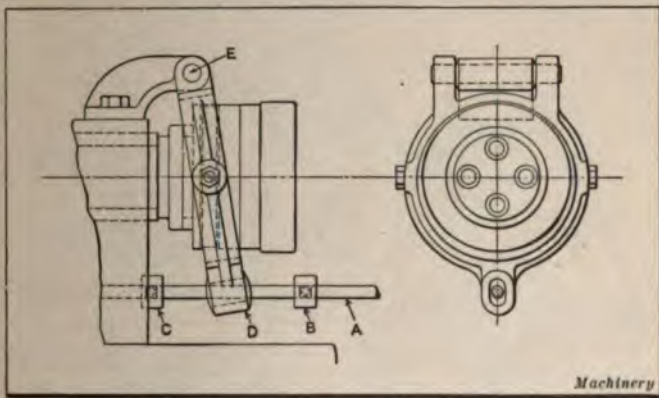

Fig. 20. Mechanism for Opening and Closing Landis Rotary Die-head

The general method of operating the die is indicated by the diagram Fig. 20. Rod *A* is attached to the slide or carriage that holds the work. This rod carries two adjustable collars *B* and *C*, which control the action of the die. The yoke ring *D*, which is pivoted at *E*, transmits motion to the die for opening and closing it. The die is opened when collar *B* engages the yoke ring at the completion of the thread-cutting operation, and it is closed when the carriage is returned to the starting point, thus bringing collar *C* into engagement with the yoke ring. The diameter adjustment of this die is obtained by means of an adjusting worm *H* (see Fig. 19), which is located in adjusting ring *P*. This worm engages the body of the die-head and moves closing ring *N*, adjusting ring *P*, operating ring *Q*, and retaining ring

S as a unit. Graduations on the rear of the die-head indicate the position or adjustment for different diameters. Any adjustment is retained by means of a lock-nut. Two closing pins *M*, located diametrically opposite each other, are fastened at their rear ends to operating ring *Q*. The cylindrical portions of these pins pass through adjusting ring *P* and enter two hardened bushings *O*, which prevents relative motion of the closing ring with the rest of the die-head, except through the adjusting worm *H*. Closing ring *N* is subjected to pressure exerted by

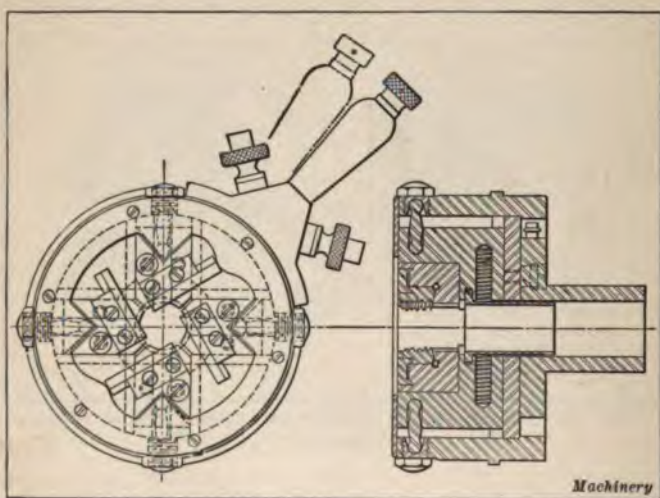

Fig. 21. Landis Automatic Self-opening Die-head

four springs. When yoke ring *R* is moved backward by engagement with the collar previously referred to, it transmits motion to operating ring *Q* and pins *M*. As this movement continues, the conical ends of the closing pins *M* engage beveled surfaces on bushings *O*, and closing ring *N*, because of the spring pressure, turns relative to the die-head body and opens the die. Four pins *I* are located on the front face of closing ring *N*. These pins carry the blocks *J*, which impart the rotary motion of the closing ring to the chaser holders. Most of the cutting strain is taken by the large trunnions *K*, to which the chaser holders are securely fastened. As the closing ring rotates, the holders

turn with their trunnions and open simultaneously. The conical points of the closing pins *M* are prevented from leaving the hardened bushings *O* by stop-screws in operating ring *Q*. The chasers are backed up at the rear and advanced in the holders by abutting screws, the correct cutting position being determined by means of a small hook gage. These chasers are sharpened by simply grinding the ends. By using right- and left-hand holders the same chasers may be employed for cutting right- and left-hand screw threads. The Landis automatic self-opening die, Fig. 21, is intended more especially for application to

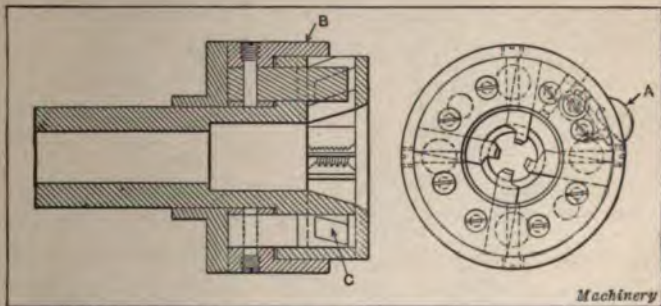

Fig. 22. H & G Automatic Die-head of Revolving Type

screw machines, turret lathes, etc., and is arranged to open when the forward motion of the turret is stopped. The continued pull of the work disengages the latch, and coiled springs within the head pull the four tangential chasers out of engagement with the work.

H & G Automatic Die-head. — An automatic or self-opening die of the revolving type is shown in Fig. 22. This die is one of the designs made by the Eastern Machine Screw Corporation, New Haven, Conn. It is tripped by the engagement of a stationary lug with a trip-lever *A* which projects from the side and is so shaped that it will operate with the die, revolving in either direction. When this trip-lever is released, the outer shell *B* of the die-head flies back very rapidly, thus opening the chasers or moving them outward in a radial direction. The chasers may be reset in the working position by using some form of yoke

which comes into contact with the outer sleeve on the rear side and holds it stationary while the inner part of the die-head is pulled back into place. The radial motion of the chasers for opening and closing the die is derived from four cams, there being one cam for each chaser. These cams *C* are in the form of bars having angular tongues at the forward ends which engage angular slots formed in the sides of the chasers. When sleeve *B* is tripped and flies back under the action of two spiral springs, it carries the four chaser cams *C* with it, and the angular

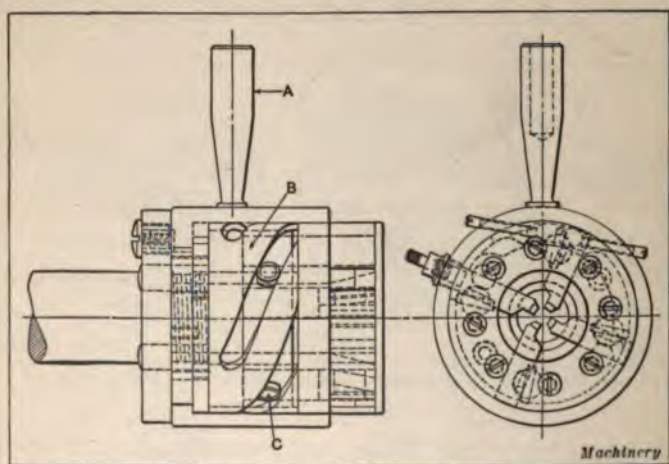

Fig. 23. H & G Automatic Die-head of Non-revolving Type

cam surfaces referred to force the chasers outward. When the die-head is closed, sleeve *C* extends forward far enough to encircle the chasers and hold them rigidly so far as outward movement is concerned. The diameter of a screw thread cut with this die may be varied above and below the normal size, within certain limits, by an adjusting screw in the front face of the die which serves to change the position of the lug engaged by trip-lever *A* and, consequently, the longitudinal position of the chaser cams relative to the chasers, which are thus moved slightly inward or outward, depending upon the direction in which the adjusting screw is turned. (The method of adjustment on an H & G die-head of earlier design differs somewhat

from the arrangement described.) This die-head is comparatively small in diameter and length for a given size of thread, which is often an important feature, especially on automatic screw machines where the amount of room for turret tools is limited.

The H & G die-head shown in Fig. 23 is provided with a handle *A* on the outer sleeve for hand closing and is a type especially adapted for use on hand-operated screw machines, turret lathes, etc. This die-head is similar in some respects to the one previously described, but differs in regard to the action when opening and closing. Each chaser has a cam which, like the form previously referred to, has a cylindrical body and an angular tongue at the forward end engaging an angular slot in the side of the chaser. Attached to the outer sleeve is a cam sleeve *B* having four helical cam grooves. These cam grooves are engaged by rollers *C* attached to a ring connecting with the chaser cams. The die-head is of the "pull-off type," the tripping action taking place soon after the feeding movement of the turret-slide discontinues. When the trip which holds the outer sleeve in position is disengaged, two spiral springs inside of the die-head force the outer sleeve to make a partial turn and then the helical cam grooves withdraw the chaser cams which, in turn, move the chasers outward. The die when hand-operated is closed by simply grasping the handle *A* and turning the sleeve until the trip again engages the fixed lug that holds it in the closed or working position. A die of this type is not always closed by hand, as it may be arranged for automatic operation. For instance, in some cases a lug might be attached to the outer sleeve for engagement with a stationary finger or arm during the indexing movement of the turret, when applied to a machine like the Cleveland automatic. The exact arrangement, of course, depends upon the type of machine. Fine adjustments of the die-head are obtained by turning screws which simply vary the location of the trip lug and, consequently, the position of the chaser cams and outer sleeve relative to the chasers.

Errington Automatic-opening Die-head. — The Errington automatic-opening dies (Errington Mechanical Laboratory, 39

828894

Cortlandt St., New York City) are made in different styles or types which are adapted to various classes of work. These dies may be tripped in three different ways: First, by stopping the travel of the turret-slide; second, by the engagement of the end of the work with a central stop located back of the dies; and, third, by the engagement of a shoulder with a tripping finger or stop on the die-head. The style *A*, which is the simplest form and is illustrated in Fig. 24, has a yoke-shaped end *B* connected with the shank. The dies proper are carried by a movable

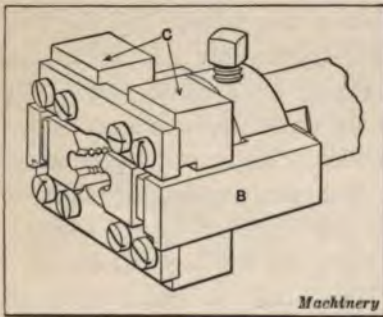

Fig. 24. Errington Automatic Opening and Adjustable Die-head

member consisting of blocks *C* to which are attached cross-bars that engage close-fitting grooves on the sides of the dies. This movable member is free to slide along the yoke *B*, either for tripping and opening the die or for closing it. Each die is supported in a radial direction by a block located between the die and yoke *B*.

When the die is tripped by arresting the motion of the turret, the action is as follows: The frame or yoke *B* of the die-head stops moving forward and the movable member containing the dies continues to advance as the result of the screwing action of the thread being cut, until each die section is in position to engage a recess or notch in the block back of it. A small wire spring interposed between the dies then forces them apart, thus opening the die. When a center stop is used, the same action occurs; that is, the end of the stock engages the stop which is located in the shank and is adjusted outward a distance depending upon the length of thread to be cut. When the stock strikes this stop, the movable member and the dies advance relative to the die frame, and the tripping action occurs. In order to reset the dies, the sliding part of the die-head may be pushed back either by hand or in any other suitable way. The die-head designated as style *E* is similar to the one just described, except that the

notches in the supporting blocks back of the dies are not beveled, but are left square in order to obtain an instantaneous opening. This die-head is adapted for cutting threads close to a shoulder.

The diameter of the screw thread cut by these dies may be varied somewhat by adjusting the supporting blocks along the inclined surfaces of yoke *B*. Screws are provided for this purpose and the adjustment is indicated by suitable graduations. The heads of these adjusting screws support the dies in an axial direction when a thread is being cut. The style *B* Errington

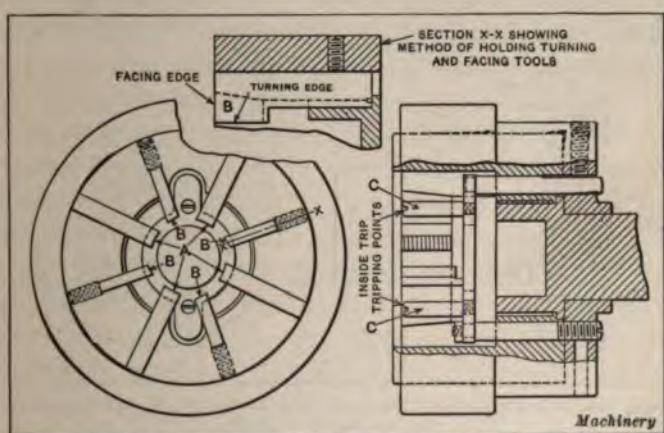

Fig. 25. Combination Turning, Facing, and External Threading Tool

die-head is intended for application to a revolving spindle, and it may be arranged to be closed by a foot-treadle, after it has opened automatically. This foot-treadle simply connects with a yoke which engages a circular plate or disk attached to the movable member of the die-head.

Murchev Combination Die. — The special design of die shown in Fig. 25 is a combination turning, facing, and external threading tool used for machining the part illustrated in Fig. 26. The work on this part is divided into a machining operation and a thread-cutting operation. First the tool passes over the piece with the threading die chasers *A* in the open position, and the four turning and facing tools *B* turn section *b* and face surface *c*.

The shape of these turning and facing tools is indicated by the detailed sectional view taken on a line *XX*. After this work has been completed, the tool is withdrawn and the die chasers are closed to the working position; then the tool is moved forward for cutting thread *b*. This automatic die is of the type provided with an inside trip which operates when the trip points *C* engage surface *c* on the work. Various designs of combination thread cutting tools have been developed by the manufacturers of this die (the Murchey Machine & Tool Co., Detroit, Mich.), for performing both external and internal thread-cutting operations in conjunction with other work. A combination tap

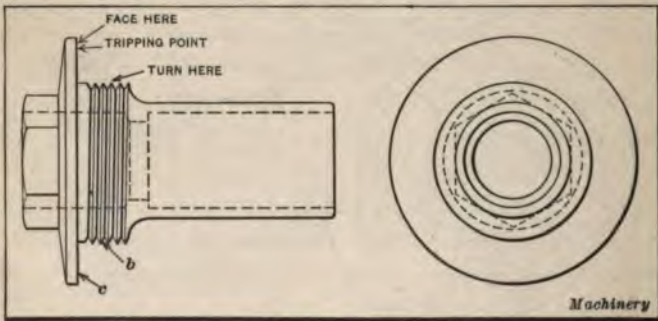

Fig. 26. Part which is Machined and Threaded by Combination Tool shown in Fig. 25

and die and also a combination boring, reaming, chamfering, facing, and tapping tool are illustrated and described in Chapter VI.

Causes of Lead Errors in Die-cut Screw Threads. — The accuracy of a die-cut thread depends primarily upon the cutting edges of the die or form of the chaser teeth and the rate at which the die advances for each revolution. Most dies are self-propelling or self-leading and move along as the screw is cut, except when the die is held stationary and the work is revolved, in which case the action is reversed but is similar so far as the practical result is concerned. As is well known, this motion of the die relative to the screw or *vice versa* is due to the fact that the cutting teeth lie in a helical path; consequently, as one tooth cuts a thread groove, the next successive tooth follows in the

same groove, and even though it may cut the groove deeper, it serves in part to steady the die like the section of a nut and force it to advance at a rate equal approximately at least to the lead of the helical path in which the die teeth lie.

If a die has too long a throat or one extending back over quite a number of teeth, it may act somewhat like a reamer when starting and merely cut away the end of the screw blank instead of forming a thread. This reaming or turning action is due to the fact that each tooth along the throat cuts such a shallow groove that the following teeth do not have sufficient bearing surface in the groove to guide the die and force it to advance along a helical path; the result is that the die either does not advance along the screw thread or moves so slowly that the teeth at the throat merely cut off the end of the screw blank.

Under certain conditions, a self-leading die may not advance at the proper rate and cut a thread of correct or uniform lead. There are several reasons why lead errors occur in die-cut screw threads. To begin with, the die or die-chaser teeth may have been cut with a hob or milling cutter of incorrect lead. The pitch of the die teeth may also have been changed as a result of shrinkage in hardening. Even though the die teeth are accurate as to pitch, the lead of the thread may not be correct, which indicates that the die does not advance a distance per revolution of the work or die, as the case may be, corresponding to the lead of its own teeth. The result is that the full sized thread that would otherwise be formed is cut away partially, thus producing a thread that is incorrect as to shape and lead.

The advance movement of a die may be affected by the amount of relief or rake at the throat of the die. If the die is ground so that it has plenty of clearance at the throat, the edges tend to feed in faster, especially when the front face has considerable rake in addition to the relief; consequently, the die tends to move forward farther for each revolution of the work than the lead of its teeth. On the contrary, if there is insufficient relief, the forward movement is retarded. The action may also be affected by dull cutting edges at the throat or by the length of the throat or chamfer.

Effect of Diameter Adjustment on Lead. — The advance of a self-leading die of the adjustable class is sometimes affected by adjusting it too much in one direction or the other from the standard size for which the chasers were hobbled. There are certain limits above or below the standard or nominal size within which it is practicable to adjust threading dies without affecting the lead to any appreciable extent. If the diameter for which the die is adjusted is too large, the lead of the thread will be increased; whereas, if the die is adjusted too much under size, the lead will be reduced. The changes in lead are

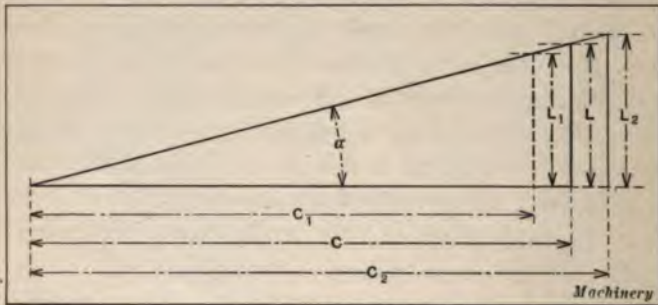

Fig. 27. Diagram showing how Lead of Thread may be varied by adjusting Die Chasers too much above or below the Diameter for which the Die is intended

due to the angle of the chaser teeth remaining the same for the different diameters. This point is illustrated by the diagram, Fig. 27, in which L represents the lead of the threading die; C , a circumference corresponding to the standard diameter for which the die is intended; C_1 , a smaller circumference; and C_2 , a larger circumference. Angle α represents the standard helix angle or the angle of a path which coincides with the die teeth. If a thread is cut to this angle α on a circumference C_1 that is considerably less than circumference C corresponding to the standard size of the die, the lead will be reduced from L to L_1 , and if the same thread is cut on a larger circumference C_2 , the lead will be increased as indicated by dimension L_2 . This is what happens when the die is adjusted for a larger or smaller diameter than the standard. (It is assumed that the adjustment is not so

great as to cause the "heels" of the chasers to drag excessively and prevent cutting action because of the lack of clearance.) The teeth of the die naturally tend to cut a thread having the same helix angle as that represented by the helix angle to which the chaser teeth were cut. If the screw blank diameter is larger than the standard, the die advances farther than it should per revolution; the result is that the lead is increased and, consequently, in the case of a U. S. standard thread, the width of the flat is reduced at the top of the thread and increased at the bottom, successive chaser teeth cutting away the left-hand side of the thread groove as the die moves to the left. The thread form undergoes a similar change if the die is applied to a diameter smaller than the standard, but in such a case the rate of advance per revolution is less than it should be, and the successive chaser teeth cut away the thread on the right-hand side of the thread groove as the die moves to the left. The fact that the lead is long in the first case mentioned causes each successive chaser tooth back of the die throat to cut along the left-hand side of the thread groove as mentioned. When the lead is less than it should be, the chaser teeth remove metal from the opposite side of the thread section. The effect which diameter adjustment might have on the lead varies according to the amount of clearance which the chaser teeth have back of the cutting edges, the smaller the clearance, the greater the effect.

Lead variations in die-cut screw threads are sometimes due to a drag on the die or excessive resistance to its motion, such as may result if the die is attached to a heavy turret-slide which does not follow up the die properly. The common method of avoiding drag such as would occur if the die were forced to pull a heavy turret-slide along with it is by using a die-holder of the type (to be described later) which has a certain amount of lost motion or float so that the turret-slide may lag behind and the die will continue to advance independently of it, provided the lost motion in the holder is not completely taken up. When the die must pull a slide along with it, the gibs of the slide should be loosened somewhat to reduce the friction as much as possible. An excessive backward pull on the die naturally causes the teeth

to generate a helical path, the lead of which is somewhat less than the lead of the die, because the cutting edges on the rear sides of the teeth are forced against the side of the thread groove and gradually reduce the rate at which the die advances, by cutting on that side.

When a die or other type of thread-cutting tool produces a screw thread which seems to be inaccurate, the discovery is often made that the defect is in the thread gage rather than in the tool itself. The manufacturers of thread-cutting equipment frequently find that accurate screws and well-constructed tools are condemned because of inaccurate thread gages.

Positive Control of Die-feeding Movement. — While most dies are "self-leading," it is sometimes advisable to control positively the longitudinal motion of the die relative to the work. This control may be utilized merely to start the die, or the arrangement may be such that the longitudinal motion of the die is controlled positively throughout the entire screw-cutting operation. This positive action may be derived from a lead-screw or from a cam, depending upon the type of machine. A lead-screw is sometimes applied to a threading machine of the bolt-cutter type (as explained in Chapter IX) especially when cutting square threads, or special forms such as the ratchet thread. For screw-cutting operations of this kind, if the die follows its own lead, the accumulated error is often considerable; that is, the lead error between two threads might be small, but the total error in the length of the screw, or a section of it, might be considerable. By using a lead-screw, the die is prevented from increasing or decreasing the lead, but, to secure satisfactory results, it is essential that the pitch of the die teeth correspond to the leading movement obtained from the lead-screw. If more than one cut is required, as when cutting a screw of coarse pitch, an indicator or thread-chasing dial of the type used on engine lathes for catching the thread is convenient on a die threading machine having a lead-screw.

The general method of cutting threads on the automatic screw machine is to use a cam that starts a die onto the work and then allows the turret-slide to lag behind somewhat so that

the die can lead itself on. As previously explained, lost motion in the die-holder allows the die to follow its own lead or move independently of the turret-slide.

Maximum Pitch of Thread Cut with Dies. — The maximum pitch of thread that can be cut satisfactorily with a threading die may be subject to considerable variation. It may depend upon several factors, such as the design of the die in regard to rigidity, the accuracy required in the screw thread, the degree of finish or smoothness, the relation between the pitch of the thread and the diameter of the screw, and the condition of the chasers, especially as to sharpness. As a general rule, when the pitch is coarser than four or five threads per inch, the difficulty of cutting threads with dies increases rapidly, although some dies are used successfully on screw threads having two or three threads per inch or less in extreme cases. Some die manufacturers would regard these pitches as too coarse for dies, whereas others have proved in actual practice that dies may be constructed which are capable of handling such heavy thread-cutting operations, if other conditions are favorable to the use of dies. Dies of special design could be constructed for practically any pitch if the size of the die, its cost, and the power for driving it were regarded as secondary, and the screw blank were strong enough to resist the cutting strains.

When considering the use of a die on a thread of coarse pitch, it is important to bear in mind the relation between the pitch of the thread and its diameter. If the screw diameter is relatively small in proportion to the pitch, there may be considerable distortion of the screw due to the torsional strains set up when cutting the thread with a die. For this reason, dies for coarse pitches work better when cutting threads on screws which are large enough in diameter to resist the torsional or twisting strains. As a general rule, if the number of threads per inch is only one or two less than the standard number for a given diameter, the screw blank will be strong enough to permit cutting the thread with a die without excessive distortion. When a coarse thread is cut by the milling process, the cutting is done much more gradually and there is not the same difficulty due to

a twisting action that is encountered when using a die of coarse pitch on comparatively small diameters.

Cutting Taper Threads with Dies. — Taper threads may be cut by using dies with chasers which taper to correspond to the taper on the work and are arranged to move outward radially as the die traverses toward the large end of the taper; by using dies of the solid or non-opening class which have the same taper

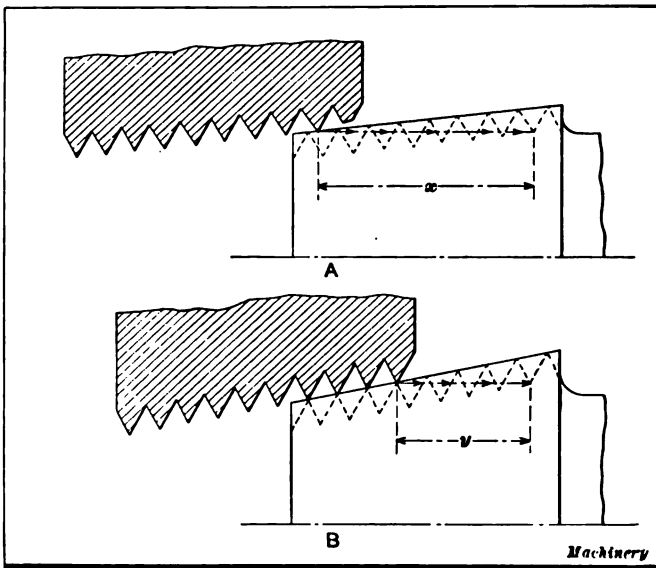

Fig. 28. Views illustrating how Longitudinal Movement of Solid Die for Taper Threading is reduced as Taper increases

as that required on the work, assuming that the length of the threaded part does not exceed the length of the cutting edges on the die or the width of the chasers; by using dies intended for parallel threads and arranged to open radially for producing a taper thread. The first type of die referred to, which has tapering chasers that move outward in accordance with the taper, is preferable for the most accurate work. The solid or non-opening die, which simply tapers to correspond to the taper screw thread to be cut, is not only limited to comparatively short screw threads but does not produce a very satisfactory

thread because ridges are left wherever each cutting edge stops cutting. The use of a solid tapering die also subjects the work to considerable torsional strain (which might be objectionable) because there are more cutting edges at work at the same time and the power required to turn the die increases as the length and taper increases. The greater the length the more cutting edges will be at work simultaneously, and the more abrupt the taper the less the number of revolutions of the die for completing the thread. The effect of the taper on the number of revolutions for completing the thread is illustrated at *A* and *B*, Fig. 28. In one case the die moves inward a distance x before the teeth cut to full depth, but when the taper is more abrupt, as shown at *B*, the die only needs to move longitudinally a distance y , in order to cut the full depth of thread.

The third method mentioned, by which a die for straight thread cutting is used for tapering work, may be applied to cutting threads having a slight taper, but is not recommended for the usual classes of taper work, which include such parts as wash-out plugs for steam boilers, the ends of faucets or cocks of various kinds, buffing lathe spindles, etc. A tapering die of the non-opening class does not require a throat or chamfered teeth on the leading side unless the taper is slight, because several cutting edges begin work at the same time, as indicated at *B*, so that there is no need for a throat, since the object of the chamfered edges in a straight die is to start the cut gradually between several teeth, instead of having one leading tooth cut the thread groove to the full depth.

Self-opening Taper-threading Dies.— A self-opening die-head for taper threading differs from one used for parallel or straight threading in that the chasers move outward at a rate depending upon the angle of taper, until the thread is cut, and then move outward suddenly to clear the work, instead of remaining in one position until the completion of the thread-cutting operation. The radial movement of taper-threading die chasers is ordinarily controlled by means of a tapering former plate, which allows the cam or scroll ring of the die-head to turn slowly as the die advances, the rate of this turning movement

depending upon the angle of the former plate relative to the axis of the die. The former plate serves about the same purpose as the adjustable slide or bar of a taper attachment for the engine lathe. Taper-threading dies of the self-opening class may be either of the inside or outside trip type.

A Geometric die of the outside trip type is shown applied to a turret lathe in Fig. 29. A tapering plate *A* is attached to a

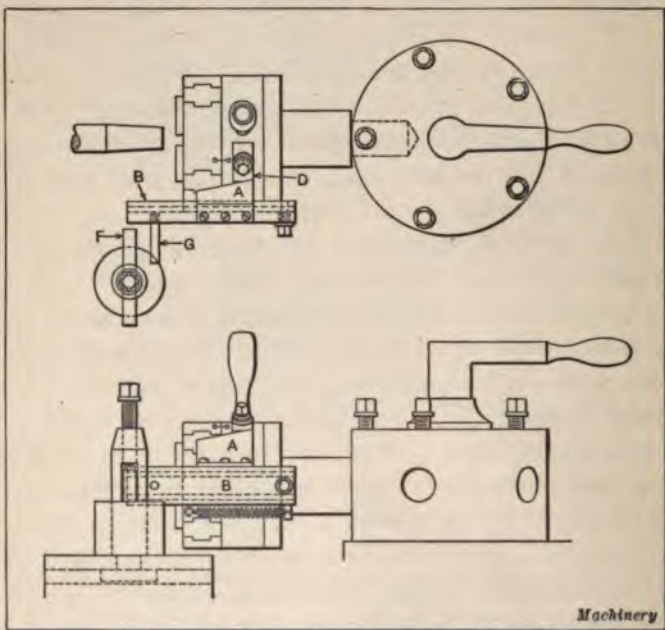

Fig. 29. Geometric Self-opening Taper-threading Die-head of Outside Trip Type

taper bar *B*, which is free to slide over a guide of T-shaped section. This guide is attached to the front part of the die-head, but not to the cam ring, which is free to turn and carries a lug *D* that is in contact with the former plate. A stop *F* is clamped in the toolpost (or is bolted to the side of the cross-slide) in position to engage pin *G* projecting from taper bar *B* of the die-head. This stop is so located that it holds bar *B* stationary as the chasers begin cutting the thread. As the die advances, lug *D* slides along the tapering surface of plate *A*, which causes the

cam ring to turn slowly and the chasers to move out gradually for producing a thread, the taper of which depends upon the inclination of the former plate. When lug *D* reaches the end of plate *A* it drops off and the chasers fly outward radially, thus releasing the die, which is then withdrawn. Die-heads of this kind are made specially for a given class of work, and in many cases must be arranged with reference to the screw machine or turret lathe on which they are to be used.

The Hartness die-head for cutting tapering threads is illustrated in Fig. 30. The front section *A* of the die-head, and the cam ring for controlling the action of the chasers, slides on the

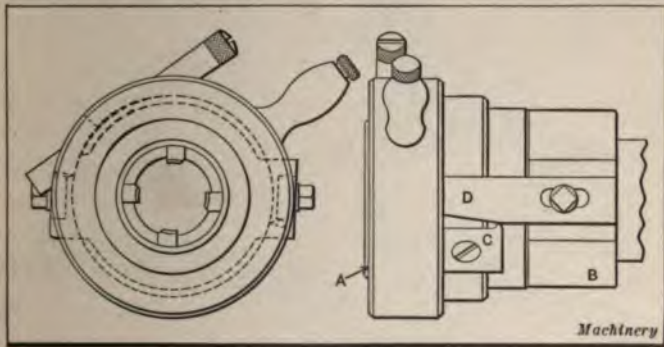

Fig. 30. Hartness Die-head for Cutting Tapered Screw Threads

rear or shank end, which is held in the turret. The forward movement of the shank of the die is arrested by one of the regular turret-slide stops after the chasers have begun to cut the thread. The front section of the die then continues to advance until lug *C* reaches the end of the tapering former plate *D*; as soon as lug *C* and plate *D* are disengaged, the cam ring quickly turns part of a revolution and the chasers are opened. Another lug and former plate are located on the opposite side of the die-head, as there is a floating connection between the two sections of the die-head.

A Geometric taper-threading die-head of the internal trip type is illustrated in Fig. 31. When this die-head is moved up to the working position, the end of the work comes into contact

with the cross-shaped gage or stop located inside the die-head. This gage is connected with the taper bar that carries the former plate, and as the chasers begin cutting the thread, the gage and taper bar are held stationary. The length of thread that is cut depends upon the position of the gage or stop, which is set previously. When the chasers have advanced the required distance, the cam lug slides off the tapering plate, thus allowing the cam controlling the chasers to make a partial turn and open them quickly.



Fig. 31. Geometric Taper-threading Die of Inside Trip Type

When dies of the former-plate type are in operation, the chasers follow the taper of the work automatically and no more power is required for cutting a taper thread than for cutting a straight thread of corresponding diameter and pitch. These dies make it possible to do the work rapidly and produce accurate, smoothly finished screw threads. The working edge of the former plate on dies of this class should so control the turning movement of the cam ring that the resultant of the longitudinal and radial movements of the chasers conforms to a straight line, so that the tapering screw will not be convex or concave. The edge of

the former plate would be a true helix if the chaser cam had a uniform rise, but since it is more convenient to make these cams plain circular arcs located eccentrically to the axis of the die, the edge of the former plate may not be made truly helical, especially if the taper of the thread to be cut is rather abrupt; for cutting threads having a slight taper, it would not be necessary to modify the former plate, as the error would be quite small; in fact, a plain inclined edge not of helical form would produce work accurate enough for ordinary requirements.

When the work is stationary and the die-head revolves, it may be arranged as follows: The bar to which the former plate is attached carries a roller at its outer end, which runs around a ring the surface of which is in a plane at right angles to the axis of the machine spindle. This ring may be attached wherever convenient, and it serves merely to hold the former plate stationary while the die-head advances.

Cutting Square Threads with Dies. — The cutting of square threads with dies is usually regarded by die manufacturers as a difficult proposition, and unless the die is made very carefully, unsatisfactory results are obtained. While square threads have largely been replaced either by the Acme or another form, some manufacturers prefer the square thread, and occasionally they are cut by means of dies. The chasers for square threading dies that are to be self-leading should have teeth that are slightly relieved on the sides by lapping. Unless there is a little side relief, the chaser teeth bind and are frequently broken. If the die is to be self-leading, however, the side relief or clearance must be very slight, as otherwise the die will not be properly supported and will cut a very inaccurate thread as to lead. A die of this kind should preferably be controlled by a lead-screw and the chaser teeth should be given enough side clearance to prevent binding. As the Acme thread is superior to the square thread and may readily be cut with dies or taps, the use of dies for square threads is not common.

Amount of Carbon in Steel for Screw Stock. — The kind of stock that is used often greatly affects the quality of thread that may be cut with a die, tap, or other type of thread-cutting

tool; in fact, the tool is often considered at fault when the stock is the real cause of the trouble. The so-called "screw stock" may have from 0.08 to 0.20 per cent of carbon, with possibly from 0.06 to 0.12 per cent of sulphur; from 0.30 to 0.80 per cent of manganese; and phosphorus up to about 0.12 per cent. Ordinarily, a steel containing from 0.18 to 0.25 per cent of carbon is very satisfactory for thread cutting, the carbon content preferably being about 0.20 per cent, or a little more. If there is too little carbon in the steel, the metal is stringy or tends to tear, and it is more difficult to cut a smooth thread.

Cutting Speeds for Threading Dies. — There are few, if any, subjects connected with machine shop practice which are more difficult to deal with in a definite, specific manner than the general subject of cutting speeds, because there are so many different factors that may have a decided effect on the speed for any one operation. If cutting speed data based on past records or experience are not available, a general idea as to what speeds are practicable is better than no information whatever. For this reason, general information on cutting speeds for threading dies will be given, and while the speeds listed may be subject to considerable variation, they will doubtless prove of some value as a starting point until tests can be made that will give more nearly correct cutting speeds.

When experimenting in order to determine what speed is the most economical, the speed should be increased gradually from a safe or conservative speed, until it is as high as possible without wearing or dulling the die chasers excessively. When a die is dulled, it is not as easily resharpened as many other metal-cutting tools, and, for that reason, it is better to sacrifice the cutting speed somewhat in order to keep the die in good cutting condition for a longer period.

Just what the cutting speed in feet per minute should be depends not only upon the kinds of material being cut but also upon the pitch of the thread and the kind of cooling compound or oil used on the die. The National Acme Co. gives the following general data on cutting speeds, based upon a vast amount of experience in screw cutting: Under normal conditions, a die

equipped with carbon steel chasers should be operated at about 30 feet per minute (surface speed at the pitch diameter) when threading cold-rolled screw stock, Bessemer and open-hearth stock, 3 to 5 per cent nickel steel, malleable iron, brass, bronze, and similar alloys. A cutting speed of 20 feet per minute is advocated when using high-speed steel chasers or those of semi-high-speed steel for cutting threads in chrome-vanadium, tough alloy steels, cast iron, drop-forgings, and all heat-treated steels.

Table I. Surface Speeds for Cutting Screw Threads in Steel with Dies

Material to be Threaded	Steel for Chasers	Surface Speeds in Feet per Minute for Different Pitches			
		3½ to 5¼ Threads per Inch	6 to 7¼ Threads per Inch	8 to 11 Threads per Inch	12 to 32 Threads per Inch
Hard Steel	} Carbon } High Speed	8	10	12	15
Mild Steel		} Carbon } High Speed	10	12	15
			12	15	20
		15	20	25	30

The speeds given, both for carbon and high-speed steel chasers, may be increased about 20 per cent when cutting threads of fine pitch.

The surface speeds given in Table I are recommended by the Jones & Lamson Machine Co., for cutting threads of different pitch in both hard and mild steel and when using either carbon or high-speed steel chasers. The figures in the body of the table represent surface speeds in feet per minute and not revolutions per minute. The speeds are increased considerably for the finer pitches, the speed recommended for from 3½ to 5¼ threads per inch being increased approximately 100 per cent, when cutting threads varying from 12 to 32 per inch. The revolutions per minute corresponding to these various surface speeds are given in Table II.

Cutting speeds have been determined on the theory that the amount of metal removed by the die per minute should be the same for cutting screws of all pitches. For instance, if a

Table II. Revolutions per Minute for given Surface Speed and Diameter

Diameter of Screw Thread	Surface Speed in Feet per Minute						
	8	10	12	15	20	25	30
	Revolutions per Minute for Different Surface Speeds						
¼	244	305	366	458	611	764	917
¼	122	153	183	229	306	382	458
⅜	81	102	122	153	204	255	306
½	61	76	92	115	153	191	229
⅝	49	61	74	92	122	153	184
¾	41	51	61	76	102	127	153
⅞	35	44	53	66	88	109	131
1	31	38	46	57	76	95	115
1¼	24	31	37	46	61	76	92
1½	20	25	31	38	51	64	76
1¾	17	22	26	33	44	55	65
2	15	19	23	29	38	48	57
2¼	14	17	20	25	34	42	51
2½	12	15	18	23	31	38	46
2¾	11	14	17	21	28	35	42
3	10	13	15	19	25	32	38

Table III. Thread Cutting Speeds for Dies Based on Removing an Equal Amount of Metal per Minute

Diameter of Screw Thread	Number of Threads per Inch	Revolutions per Minute	Surface Speed, Outside Diameter	Cubic Inches Removed per Minute
¼	20	1062.0	69.5	0.5896
⅝	18	691.5	56.5	0.6004
¾	16	453.0	44.5	0.6025
⅞	14	297.5	34.0	0.6009
1	13	224.5	29.0	0.6084
1¼	12	169.5	25.0	0.6085
1½	11	128.7	21.0	0.6147
1¾	11	117.0	21.0	0.6201
2	10	88.5	17.0	0.6177
2¼	10	81.7	17.0	0.6225
2½	9	61.7	14.0	0.6170
2¾	9	57.6	14.0	0.6276
3	8	40.6	10.6	0.5948

die is found to operate satisfactorily when cutting a thread in a certain material, whatever fractional part of a cubic inch of metal is removed per minute is determined, and then cutting

speeds for the same material and for coarser or finer pitches are based on removing an equal amount of metal per minute. While this method seems to be logical, it involves a wide range of speeds if extended to include very coarse and very fine pitches. Table III, which applies to U. S. standard threads, was calculated on the basis of removing approximately 0.6 cubic inch of metal for threads of all pitches. As the table shows, the surface speeds vary from 10.6 to 69.5 for U. S. standard threads ranging from 1 to $\frac{1}{4}$ inch in diameter, and the speeds in revolutions per minute for the same range of diameters vary from 40.6 to 1062. This table is based on actual practice in cutting threads on screw stock with self-opening dies at the plant of the Greenfield Tap & Die Corporation.

CHAPTER V

CHASERS FOR THREAD-CUTTING DIES AND CHASER GRINDING

THE chasers used in screw-cutting dies vary in regard to the form of the teeth, the angles of the cutting faces or edges, and the position relative to the axis of the die. The cutting qualities of a die and the accuracy of the screw threads produced by it may be affected greatly by the form of the teeth or the location of the cutting faces or edges of the chasers relative to the axis of the work.

There are three methods of forming the teeth of die chasers. One is with a hob having helical-shaped cutting teeth. A second method is by using a milling cutter which has teeth perpendicular to the axis and is set to the helix angle of the screw thread when milling the teeth of a chaser. The cutter is fed across the chaser blank and forms a series of straight teeth corresponding in cross-section to the shape of the thread to be cut. The third method is by the use of a milling cutter like the one just referred to, with teeth which are at right angles to the axis (not helical), but which, after being set to the proper helix angle, is sunk into the end of the chaser blank and forms teeth that are circular in a lengthwise direction instead of being straight.

Hobbed Chasers. — The hobbed chasers represented by diagram *A*, Fig. 1, are formed by a tool which is similar to a tap, except that there are usually a greater number of flutes and cutting edges. The teeth are helical, corresponding to the threads of a screw, instead of being annular or at right angles to the axis. The chaser teeth formed by a hob are like sections on the thread of a nut, except that they are given a slight amount of relief or clearance back of the cutting edges. The clearance may be obtained by using a hob of the same size as the die and

setting the chasers (which are held in a special fixture) a little off center while hobbing, or a hob that is somewhat smaller than the nominal size of die may be used to obtain clearance, especially when recutting the die chasers while they are held in the die-head. The "heel" or rear corner of each chaser is removed after hobbing by beveling it in as far as the center line to provide clearance.

Milled Chasers.—Milled chasers having teeth which are straight in a lengthwise direction, instead of curved, are shown at B, Fig. 1. These teeth are formed by a cutter having teeth

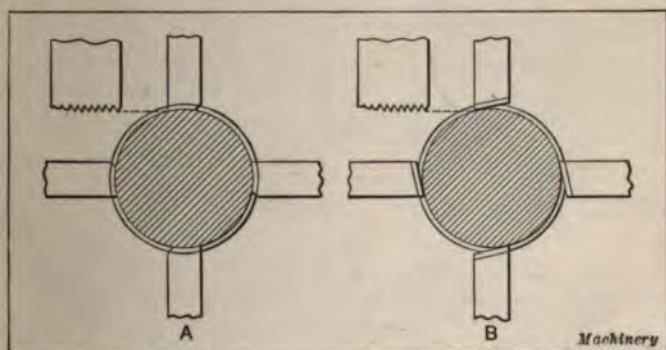

Fig. 1. (A) Hobbed Die Chasers. (B) Straight Milled Die Chasers

which are perpendicular to the axis, instead of being helical, and when milling the teeth the cutter is fed straight across the end of the chaser.

The chasers in the Hartness automatic dies are milled, but the teeth are circular, in a lengthwise direction, instead of being straight. According to the manufacturer, these chaser teeth are so formed that the front teeth form a cutting tool while the rear teeth form a lead-screw or act like the section of a nut on the threads formed by the leading side of the die. The milling cutter has teeth which are perpendicular to the axis, and it is $2\frac{1}{2}$ inches in diameter for all chasers, regardless of the pitch of the teeth or the diameter of the die in which they are to be used. The bearing of the chaser teeth on the finished thread is obtained by setting the cutter in such a position relative to the

cutting edge of the chaser, when milling the teeth, that the full depth of the cut extends to the cutting edge only at the throat of the chaser. The reason given for confining the cutting action to the leading cutting edges of the chasers is that, if the chasers are not made in this way, pressure in the direction of the axis of the screw causes the cutting edges to dig into the threads already cut, thus thinning them and changing the pitch of the thread. In order to prevent any such action, the rear chaser teeth on the Hartness dies are made to serve practically the

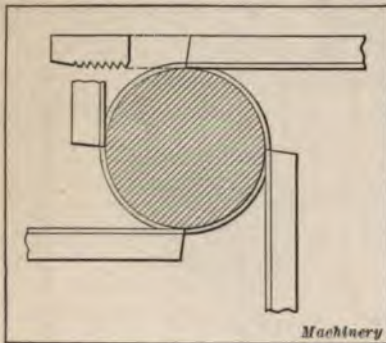

Fig. 2. Milled Chasers of Tangential Type

same purpose as a nut, in order to steady the die and cause it to move forward at a uniform rate and in accordance with the lead of the thread being cut. It is also claimed that this feature has an important effect in producing clean, finely finished threads, as the chasers have a slight burnishing effect and impart a close grained surface to the thread.

Milled Chasers of Tangential Type. — Still another form of milled chaser is illustrated in Fig. 2. These chasers are the form used on the Landis die-head previously described and are set tangentially to the work. The milled teeth extend throughout the length of the chasers and they are in the form of straight parallel ridges corresponding in cross-section to the shape of the screw threads they are intended to cut. These chasers are sharpened by grinding on the ends, and as they become shorter as the result of repeated grinding, they are simply adjusted to the correct cutting position. The throat of the chaser and the front teeth shape the thread, while the rear teeth extend across the center line and take a bearing on the work just back of the cutting end of the tool. This is to make the four chasers act as a lead nut for controlling the forward movement of the die in accordance with the lead of the thread being cut.

Angle of Chaser Throat or Chamfer. — The leading side or corner of each chaser in a die-head is usually beveled as shown in Fig. 3. This beveled edge is known as the "throat" of the chaser and serves to begin the cut gradually when the die is first starting a thread and also when it advances. At *A* is shown a chaser at the point of starting a cut, and *B* represents the position of the chaser after it has advanced far enough to begin forming a "full" or complete thread. The throat of the chaser not only inclines relative to the axis of the die (or screw being cut), but it is given clearance back of the cutting edge in a

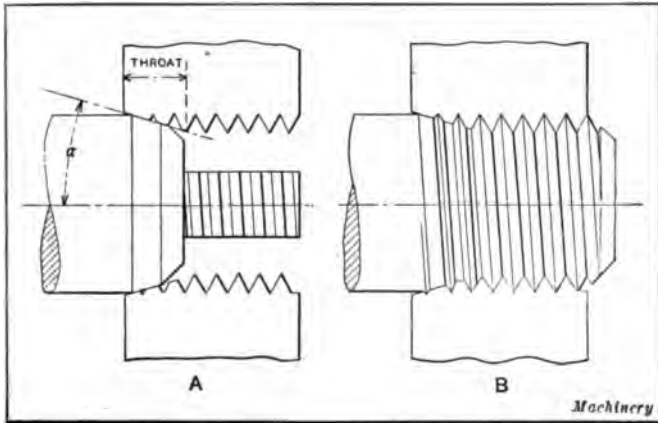

Fig. 3. Diagrams illustrating how Throat of Die serves to start Thread-cutting Operation gradually by distributing Work between Several Chaser Teeth

circumferential direction. In some cases, the throat angle α must be abrupt in order to cut a full thread close to a shoulder. Aside from a requirement of this kind, the throat should preferably be ground so that the work of cutting a thread to the full depth is distributed over at least two or three teeth on the leading side of the die. It is common practice to grind the throat at such an angle that the beveled part extends from the root or base of the leading or most advanced tooth in the set of chasers back to the third tooth, which may be slightly beveled. The throats of some dies extend back over four, five,

or more teeth, although the shorter chamfer is more common. Each chaser should be ground to the same angle and so that each throat will be the same distance from the axis of the die when in the die-head.

The throat angles of chasers for the Hartness dies depend upon the pitch of the thread. The angles for different pitches are shown in Fig. 4, which also shows the type of fixture used for holding the chasers while grinding them. This fixture may be

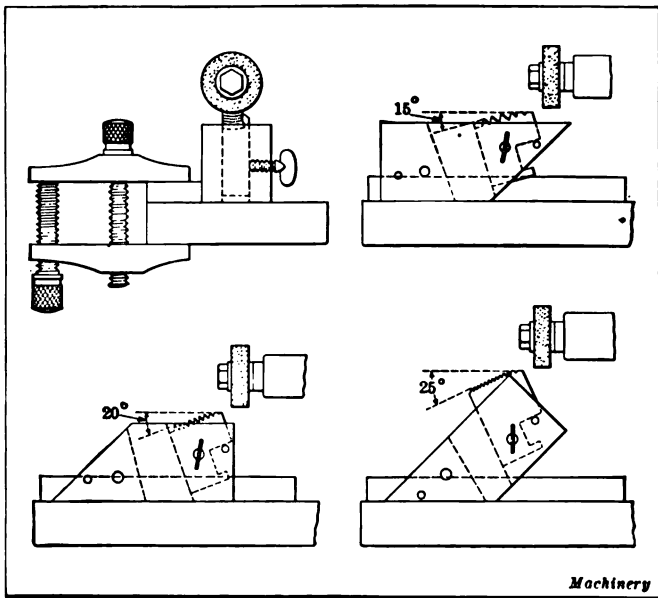

Fig. 4. Throat Angles for Chasers and Fixture for Grinding

applied to different types of grinding machines by clamping a guiding strip to the grinder table, as indicated. A throat angle of 15 degrees relative to the axis of the die is recommended for chasers intended for cutting threads varying from 4 to $5\frac{1}{2}$ per inch. The angle of 20 degrees is intended for pitches varying from 6 to 8 per inch; and 25 degrees, for pitches of 9 or more per inch. The object of decreasing the throat angle for the coarser pitches is to increase the length of the throat somewhat and distribute the work of cutting over more of the chaser teeth.

Die-chaser Throat that is Ineffective. — A method of chamfering dies or die chasers that sometimes causes trouble is illustrated at *A*, Fig. 5. The die chaser may appear to have considerable chamfer, but when the relation between the throat of the die and the work is considered, it will be seen that there is little effective chamfer or throat. This is due to the fact that the beveled edge extends beyond or outside of the root or bottoms of the chaser teeth, where it cannot be effective when a screw thread is being cut; consequently the entire work of cutting the thread groove is imposed upon the leading tooth of each chaser. The chamfer, or throat, to be effective should begin near the root

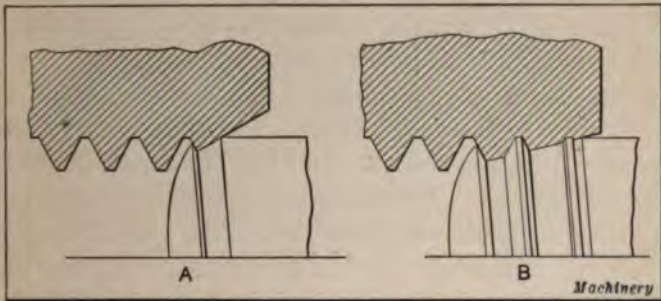

Fig. 5. (A) Throat that extends considerably beyond Roots of Chaser Teeth so that it is not Effective. (B) Throat that is Effective

of the leading tooth (as indicated at *B*), so that it assists in the work of cutting the thread groove. If the die is held in a floating holder and the work is likely to be considerably out of line, the edges can be beveled beyond the root of the teeth somewhat, but this extra chamfer should not be considered as a part of the throat.

Effect of Chaser Throat Relief on Action of Die. — The relief or clearance at the throat of a chaser should be just enough to insure free cutting, and is subject to variation according to the diameter of the die or the screw that is cut by it and often by the conditions under which the die is used. It is essential to have the correct amount of relief back of the throat, because insufficient relief may prevent cutting action altogether or retard the action of the die, and prevent it from advancing at the proper

rate. If a die has excessive relief, the chaser teeth are weakened and the die tends to move forward too rapidly when controlling its own lead, especially when cutting soft material like brass. The result is that threads are left rough and may be almost entirely cut away in extreme cases. If the rear or turret side of the thread is rough, this indicates that the die is leading or advancing too fast; and if the opposite or front side is rough, this shows that the die is not advancing fast enough. The leading of the die or the rate of its advance may be varied by changing the amount of relief or clearance in the throat of the die chaser. The greater the relief, the faster the die will lead, and *vice versa*. Relief, however, is not the only thing that may affect the leading qualities of a die. The principal causes of lead errors are explained in Chapter IV (see page 102).

Grinding Throat of Die Chaser. — The throat of a die chaser should be ground both with reference to its inclination relative to the axis of the die and also the amount of relief or clearance for the cutting edge. If the chasers to be ground have hobbled teeth or milled teeth which are circular in a lengthwise direction, it is common practice to use a wheel which is from $\frac{1}{16}$ to $\frac{1}{4}$ inch larger in diameter than the nominal size of the die or the size of the screw the die is intended to cut. Ordinarily, a wheel about $\frac{1}{8}$ inch larger than the die size is employed. The center of the wheel is offset relative to the center line of the chaser when grinding, in order to obtain clearance for the cutting edge of the throat. The exact method of grinding depends upon the type of machine used. In some cases, the chaser is held in a fixture which can be tilted to the throat angle and is graduated to indicate both the angular position and the amount that the chaser is offset relative to the wheel. The fixture shown in Fig. 4 is in the form of a block arranged to hold a chaser at the three angles recommended, by changing the position of the chaser and the block.

The amount of clearance back of the cutting edge should be as small as possible without preventing a free cutting action. While it is common to use a wheel that is about $\frac{1}{8}$ inch larger than the nominal size of the die, the use of a larger or smaller

diameter wheel has less effect on the amount of clearance than the distance that the wheel is offset. For instance, if the wheel has a radius r (see diagram *A*, Fig. 6) and this wheel is offset an amount x , a certain clearance will be obtained. Now if the size of this wheel were increased to some radius R , this would not affect the clearance to any great extent, assuming that the amount of offset x remained the same. On the other hand, if a wheel having a radius r is offset first a distance x and then some greater distance y , as shown by diagram *B*, this will increase the amount of clearance decidedly.

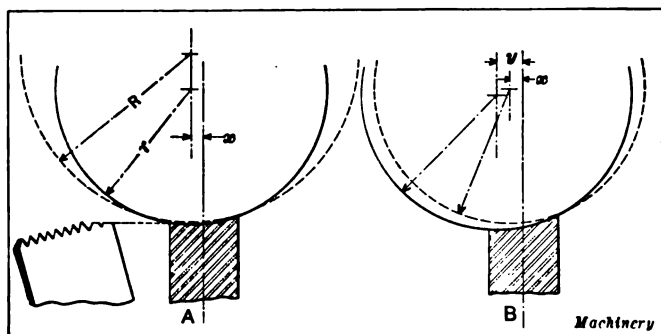

Fig. 6. Relative Relief obtained by varying Diameter of Grinding Wheel and Distance Wheel is offset from Center Line of Chaser

As a general rule, most of the grinding should be done on the throats of chasers, the faces being ground as little as possible. Repeated grinding on the throat extends the latter back farther from the leading side of the chaser (assuming that the same throat angle is maintained as it should be); if, as the result of repeated grinding, the die finally will not cut a full thread close enough to the shoulder, this can sometimes be remedied by grinding away the front edges of the chasers, so that they will clear the shoulder.

The method of grinding the throat of a hobbed chaser with a "Geometric" chaser grinder is illustrated in Fig. 7. A large grinding wheel is used in this case and the chaser is swiveled about the wheel to give the clearance surface or throat a curved form. If the chaser for a one-inch die is to be ground, the scale

on the pivot of the vise is set to the radius of the die or one-half inch minus the depth of one tooth or thread. The die is located by a stop on the vise and the jaws of the latter are adjusted to the right or left of the center (depending upon whether the chaser is for right- or left-hand threads) just enough to give the proper clearance. After releasing the swiveling base of the vise-slide by unscrewing the small handle shown, the chaser is ground by swinging it to and fro about the wheel, at the same time slowly feeding it in toward the wheel by turning the handwheel of the



Fig. 7. Geometric Chaser Grinder set up for Grinding Throat of Hobbed or Tap-formed Chaser

slide feed-screw of the vise. After grinding one chaser, a stop ring is set to control the inward feeding movement so that the remaining chasers of the set are ground alike, or to correspond with the first one. When using the same machine to grind the throat of milled chasers having straight teeth, the die is traversed back and forth across the face of the grinding wheel; as the chaser is being traversed it is also fed forward by the handwheel of the feed-screw.

Fig. 8 illustrates a method of grinding the throat of a spring die. A cone-shaped wheel of suitable diameter is used, the axis of the wheel being offset slightly with reference to the axis of the

die to give the throat or chamfered part a slight relief. Spring dies are not ordinarily ground in the throat, but are sharpened by grinding each of the radial cutting faces by using the flat face of an ordinary dish-shaped or saucer wheel. If dies have been forced to cut when dull, they may be injured to such an extent that some grinding in the throat as well as along the cutting faces is necessary in order to obtain a sharp cutting edge. If the throat is ground away considerably, it may be necessary to grind back the ends of the lands or prongs, especially if there is a shoulder on the work which would strike these prongs before the thread has been cut the required length.

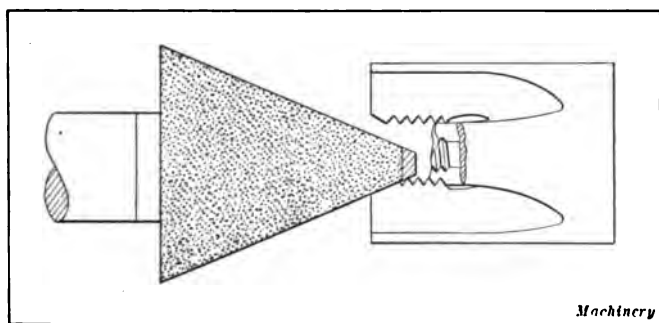

Fig. 8. Method of Grinding Throat of Spring Die

It is of especial importance to have as little clearance as possible on the chasers used for brass work, because the throats of the chasers steady the die when starting to cut a thread. When it is desired to cut a thread close up to a shoulder in brass, the chaser teeth are sometimes relieved on the sides instead of chamfering the teeth. This relieving may be done by means of a brass lap, the working edge of which is formed to an angle of about 50 degrees for a 60-degree tooth, so that the lapping may be confined to one side of a tooth. This beveled or working edge of the lap is charged with a suitable abrasive, and the side clearance is given to two or three of the leading teeth. When chasers are set tangent to the work, as shown in Fig. 2, the throat like the teeth has a natural clearance due to its tangential position.

Rake Angles for Die Chasers. — The relation between the front cutting faces of die chasers and the axis of the screw thread they are to cut varies for different materials. As a general rule, the front face of each chaser in a set lies in a plane intersecting the axis of the die or screw thread (as shown at *A*, Fig. 9) when the die is to be used for cutting threads on cast brass. For yellow brass, machine steel, or tool steel, the chasers are usually given rake by locating the cutting faces in planes that

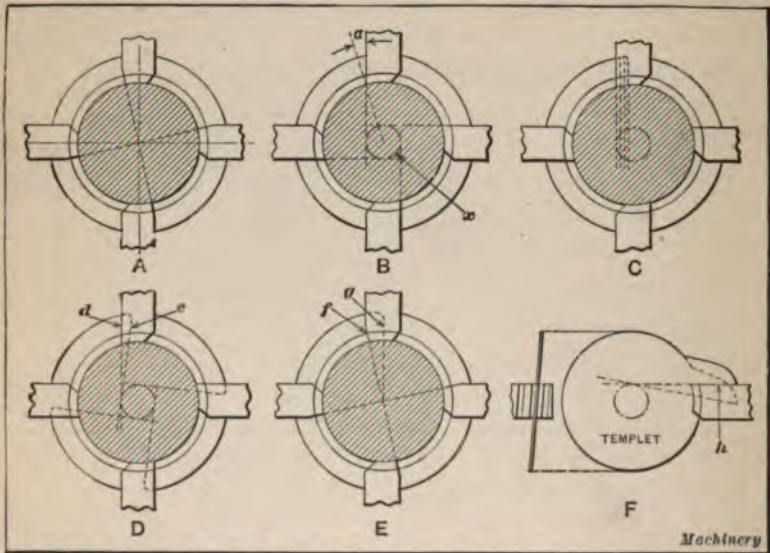

Fig. 9. Rake Angles or Relation between Front Face of Chaser and Axis of Work

are in advance of the center on the cutting side, as shown at *B*. There is considerable difference of opinion among manufacturers and users of dies as to the amount of rake that will give the best results. As a general rule, the tenacious or tougher materials which have the quality of flexibility without brittleness, like wrought iron, steel, copper, and pure aluminum, require positive rake. If there is not enough rake, more power is required for revolving the die or work and the chasers tend to tear the metal. Materials having a granular structure like cast brass and cast iron should ordinarily be cut with chasers having little or

no rake. An excessive amount of rake would cause the chasers to ride and dig in alternately. Some grades of cast iron may be threaded satisfactorily with dies intended for steel. Most aluminum castings, because of the zinc in their composition, cut very much like brass and should preferably be threaded with chasers with little or no rake.

Many dies used for cutting threads in machine steel have the front faces located a distance ahead of the center equal to about one-fifth the radius of the die. In other words, the plane of the front face is tangent to a circle x , see B , Fig. 9, having a radius equal to one-fifth the radius of the die or a screw cut by the die. The angle α corresponding to the rake of the die chaser is about 12 degrees when the front face is one-fifth the radius off center. This rake corresponds approximately to the angle of rake or slope that would be given to a lathe turning tool for use on machine steel, although the rake is subject to more or less variation. For threading copper and tobin bronze, dies having a rake of about 14 degrees have given satisfactory results. Die chasers are sometimes given negative rake when the die is to be used on very soft "greasy" brass, the face of the die being slightly back of the center instead of in advance.

Some of the die chasers for the Wells self-opening die are ground to a slight angle along the front face above the throat instead of leaving this face parallel to the axis of the die or the screw which the die is to cut. It is claimed that a die equipped with such chasers has a tendency to throw the chips ahead and avoid clogging. This method of grinding the die chasers is the same in principle as that employed on the "gun taps" made by the Greenfield Tap & Die Corporation.

Maintaining Rake Angle of Chaser when Grinding. — The front faces of chasers should always be ground so that they are in the same position relative to the axis of the die, assuming that the die has been cutting properly and a change is not desired. Chasers located with the front faces in advance of the centers (as illustrated at C , Fig. 9) are sometimes ground back so that the faces are always parallel to the side of the chaser (as indicated by the dotted lines), which reduces the

angle of rake and impairs the cutting action of the die. In order to maintain this angle, it is necessary to incline the faces of the chasers as they are ground back so that they will remain tangent to a circle at the center representing the amount of offset as indicated by diagram *D*. When a chaser has been ground back considerably, it appears to have more rake, which may account for the difference of opinion in regard to rake angles. A chaser which is radial may also appear to have "positive" rake after repeated grinding, even though the cutting face is still in a radial position. For instance, when the chaser face is at *f* (see diagram *E*), the cutting action will be practically the same as when the chaser is ground back to some point *g*, since the cutting faces are radial in each case. If the position of the cutting face, however, relative to the axis of the work were not considered, one might suppose that a chaser ground as at *f* would have negative rake, whereas with the cutting face at *g* there would be positive rake.

A simple form of templet and the method of using it to test the front cutting face of a chaser is illustrated at *F*. This templet is made of thin sheet steel and has the same radius as the die or the outside radius of the screw the die is to cut. The gaging edge *h* is given the same location relative to the axis of the templet that the cutting faces of the chasers are to have relative to the axis of the die. The gage is used by simply placing it between two chaser teeth and turning it around until the testing edge *h* is in contact with the chaser face that should coincide with it. If a die is to work satisfactorily, each cutting face must be in the same position relative to the center or axis of the die. Dies are frequently used which have one cutting edge in a radial position and the others somewhat in advance of the center or back of it. A die ground in this way will not do good work, especially when cutting threads in steel. In order to maintain a uniform rake angle, all chasers should be ground so that the faces of chasers that are diametrically opposite are parallel, assuming that the die has an even number of chasers. The rake of a chaser of the tangential type may be varied according to the requirements by simply grinding the end of the chaser to the angle desired.

Chasers for Cutting Smooth Threads on Pipe. — Many dies used for cutting threads on pipe do not give satisfactory results, ragged or torn threads often being produced. After the introduction of steel for pipes, defective threads were even more numerous than before, although it has been demonstrated that steel pipe can be threaded as rapidly and efficiently as wrought iron when the correct form of die is used. Experiments of the National Tube Co., Pittsburg, Pa., for determining the cause of defective pipe threads showed that the angle of rake is of par-

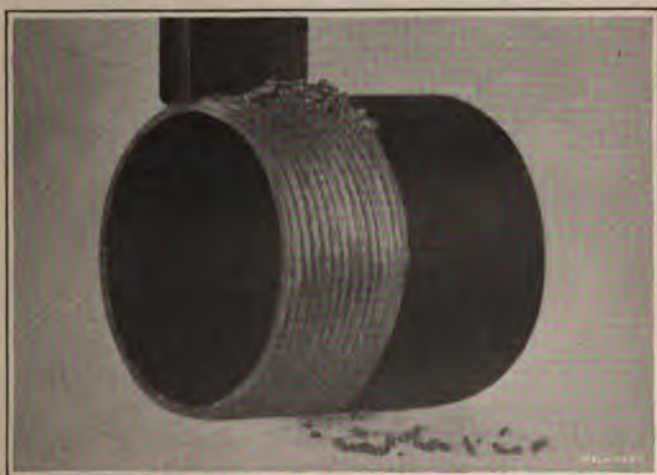

Fig. 10. Rough, Poorly formed Pipe Thread cut with Die having Insufficient Rake

ticular importance. Other important factors are as follows: Lack of adequate chip space; improper grinding of the throat; excessive or insufficient clearance; and incorrect number of chasers. Steel pipe is naturally soft and tough, and, for that reason, it was quite difficult to thread with some of the dies used for wrought iron which had radial cutting faces or chasers without positive rake. Fig. 10 shows the kind of pipe thread that is cut when the die is without rake and simply pushes the metal off, instead of operating with a clean cutting action. Fig. 11 illustrates the results obtained when the chaser is properly made and ground. This die has positive rake, which is preferable

for wrought iron as well as steel. The form of chaser illustrated at *A*, Fig. 12, is recommended for cutting ordinary steel pipe. The form of cutting edge illustrated at *B* is recommended for use on open-hearth steel pipe, which requires a rather long and gradual "lip" or curvature back of the cutting edge, owing to the toughness of the material. The form of chaser illustrated at *C* is considered unsuitable for threading either steel pipe or wrought iron. The angles of rake recommended vary from 15

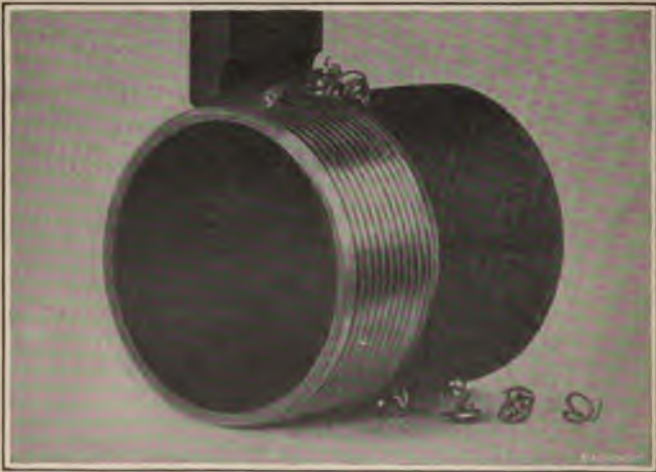

Fig. 11. Result obtained when Die is given Proper Amount of Rake

to 25 degrees, depending upon the conditions. For threading open-hearth steel pipe, the rake angle should be 25 degrees.

It is important to have the proper amount of space in front of each chaser to allow for the accumulation of chips. If there is not enough space, the chips frequently pack tightly in front of each chaser and mar or tear the thread. An approved form of chip space for a pipe die is illustrated in Fig. 13. The curvature of this space is such as to provide an easy path for the chips to follow; at the same time, the back of the chaser is rigidly supported. The chip space is of especial importance on dies intended for cutting open-hearth steel pipe, because the chips from this material are usually long and tough.

The throat or chamfer of pipe dies should extend over about three threads or teeth. As the heaviest cutting is done in the throat of the die, this section should have a little more clearance than the rest of the chaser teeth, which applies to thread-

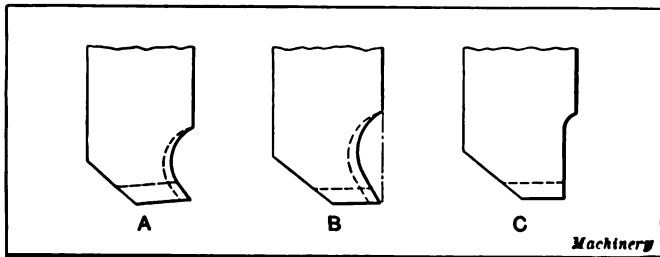

Fig. 12. Different Methods of grinding Chasers of Pipe-threading Dies

ing dies in general. If a tooth in a die is broken away, it is preferable to remove the remaining part entirely by grinding with a thin wheel, because the broken part tends to tear or roughen the thread. To obtain the best results with pipe dies,

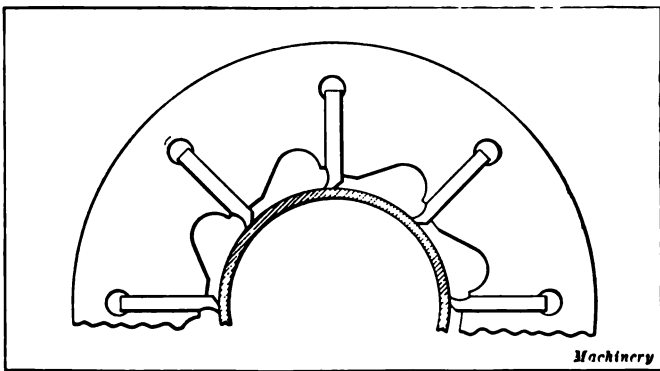

Fig. 13. Approved Form of Chip Space for Pipe-threading Die

the number of chasers should be varied according to the size of the die, four chasers being used for diameters up to $1\frac{1}{4}$ inch; six chasers for diameters from $1\frac{1}{2}$ to 4 inches; eight chasers for diameters from $4\frac{1}{2}$ to 8 inches; twelve chasers for diameters from 9 to 12 inches; fourteen chasers for diameters from 13

to 16 inches; and sixteen chasers for diameters from 17 to 20 inches.

Steel for Threading Die Chasers. — There is some difference of opinion regarding the relative merits of carbon steel and high-speed steel for the chasers of threading dies. The results obtained with different steels may depend considerably upon the exact composition of the steels in question and the heat-treatment to which they are subjected. In general, carbon steel chasers are preferable for cutting smooth, accurate screw threads, owing to the fact that they retain a fine cutting edge better than chasers made of high-speed steel. A fine sharp cutting edge on a high-speed steel chaser tends to crumble slightly. The result is that screw threads cut with high-speed steel chasers are not so smooth, although the cutting speed can be considerably higher. As a general rule, carbon steel is recommended when finish is of especial importance, whereas high-speed steel is preferable when maximum production is the principal object and a nicely finished thread is of secondary importance. Incidentally, many manufacturers or users of dies order the more costly high-speed steel when carbon steel or "semi-high-speed steel" would be preferable. The semi-high-speed steel, which has been used for many die chasers, contains much less tungsten than the steel ordinarily used for turning tools.

The National Acme Co. recommends the use of carbon steel chasers for cold-rolled screw stock, Bessemer and open-hearth steel, 3 to 5 per cent nickel steel, malleable iron, brass, bronze, and similar alloys. High-speed steel chasers, or those made of semi-high-speed steel, are recommended for cutting threads in chrome-vanadium steel, tough alloy steels, cast iron, drop-forgings, and all heat-treated steels.

CHAPTER VI

DIFFERENT CLASSES OF TAPS AND CAUSES OF ERRORS IN TAPPED HOLES

THE relation between taps and other tools that may be used for cutting screw threads in holes is similar to the relation between dies and the various classes of equipment that are adapted for cutting external threads. The principal points of similarity between taps and dies pertain, first, to the extent of their application, and, second, to the factors that govern their use. Taps are employed for most internal thread-cutting operations, just as most external threads are cut with dies, and the extent to which taps are applied for internal threading gradually diminishes as the diameter of the threaded part increases above a certain size, which applies also to the use of dies in cutting external threads.

Conditions Governing Use of Taps.— While practically all small holes that are to receive machine screws, studs, bolts, etc., are threaded by means of taps, tools of this class are not suitable for cutting a great many of the larger screw threads. It is impracticable to draw a definite dividing line on the basis of diameter alone, since there are frequently other important conditions that affect the problem. Whether or not taps may be used to advantage often depends upon: (1) Number of parts requiring screw threads or amount of work; (2) diameter and pitch of thread; and (3) the relation between thread-cutting and other machining operations. If cutting the thread is the principal or only operation, and especially if the parts are required in large numbers, a tap might be used even for quite large diameters in order to cut the threads quickly. Pipe fittings, which have comparatively fine threads, are an example.

The equipment that is available in a shop is another important point, since there is often a close relationship between

investment and method. No experienced manufacturer or shop superintendent would consider making or buying high-priced taps for a certain job unless the number of parts to be tapped were large enough to warrant the expenditure. For cutting a few threads, the engine lathe might be more economical and often preferable regardless of the quantity, either because of the diameter of the thread, pitch, or relation to other machined surfaces. In one sense, every tap is a special tool, since it can only be used for cutting one pitch of thread, and is usually intended for only one diameter, although in some cases a slight adjustment may be made above or below the standard size. For that reason, taps, as well as dies, are used principally on machine tools that are designed more especially for producing duplicate parts in quantity than for handling a large variety of work. For instance, practically all the internal thread cutting on turret lathes or automatic screw machines is done by taps, just as most of the external thread cutting is done by dies.

Non-collapsing Taps. — The fixed or non-collapsing tap is the most important class if judged by the extent to which it is used. Non-collapsing taps may be divided into three general types, as follows: (1) Solid taps, or those formed of one solid piece of steel; (2) adjustable taps, which usually have inserted blades that can be adjusted a certain amount radially; and (3) inserted-blade non-adjustable taps. All these taps may also be further classified according to whether they cut straight or tapering screw threads, and also with reference to their intended use. For example, there are hand taps for use when tapping holes by hand; taper taps for tapping nuts in regular tapping machines; staybolt taps for tapping the inner and outer sheets of steam boiler fireboxes; pipe taps for tapping holes for standard pipe sizes; screw machine taps for use on automatic screw machines; and various other classes.

While solid taps are the cheapest and are used the most, a great many adjustable taps are found in modern shops and applied especially when accuracy is essential. A solid tap is liable to slight changes in diameter due to hardening, and there is some reduction in diameter due to wear. By using a tap

that is adjustable, a standard size may readily be maintained. The adjustable tap may be made from a solid piece of steel and may be split so as to permit expanding it sufficiently to compensate for wear, or it may have inserted blades or chasers arranged for radial adjustment. With an adjustable tap of the inserted-chaser type, the body of the tap may be made of a comparatively low-priced material, and this main part of the tap may be used indefinitely, the chasers being replaced when necessary.

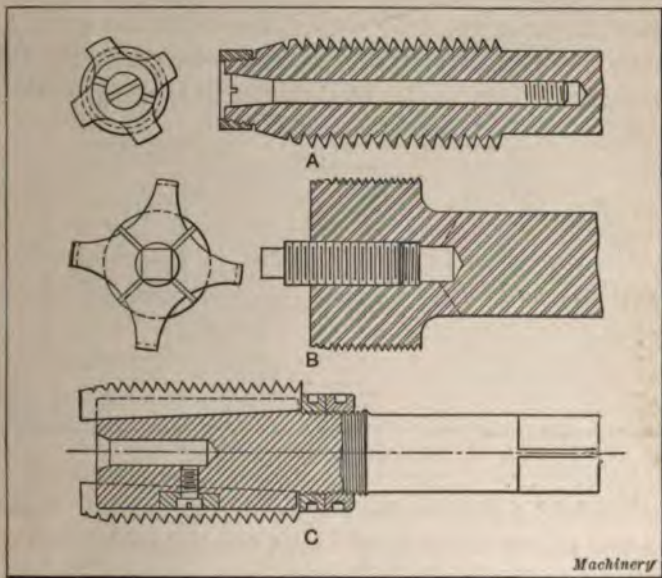

Fig. 1. Taps that can be adjusted to compensate for Wear or for varying Size

Examples of Adjustable Tap Design.—Several different forms of adjustable taps are illustrated in Fig. 1. A one-piece split type is shown at *A*. The tap is split through the center and expanded by means of the conical-headed screw shown. A nut engaging the tapering thread at the end of the tap serves to hold the two sections firmly together. One serious defect of a tap of this kind is that the tap is not expanded uniformly, and, for that reason, does not cut an accurate thread; the inaccuracy, however, would be very slight for adjustments that might

be necessary in order to compensate for wear and maintain a standard size. Another form of split adjustable tap is illustrated at *B*. The tap is split through the center of each flute and expanded by the screw shown, which is slightly tapering. The smaller taps of this kind have slotted screws for screw-driver adjustment. While these types are superior to the solid form for tapping large numbers of duplicate parts to a given size within close limits, the inserted-blade type of tap is preferable and is used considerably, especially on accurate work. When extreme accuracy is necessary, it is common practice to use a hand-operated inserted-blade tap for finishing holes previously tapped on a machine. Taps of this kind should be so designed that the

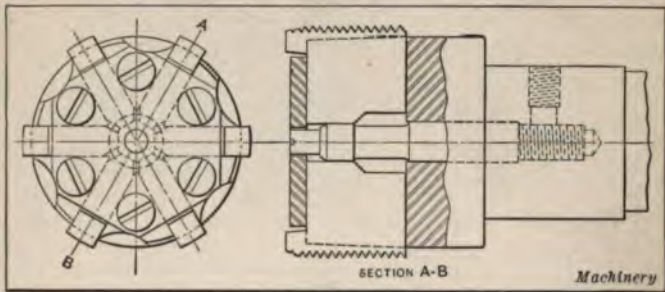

Fig. 2. Murchey Adjustable Sizing Tap

blades are held rigidly to the body of the tap and preferably in such a way that the means for locking or adjusting the blade does not interfere with the use of the tap.

The adjustable tap shown at *C* is so designed that it can pass clear through a hole or tap to the bottom of a "blind" or closed hole. The blades are located in longitudinal grooves or slots which taper on the bottom, so that any change in the lengthwise position of the blade increases or decreases the tap diameter. The tap blades are securely held in position by binder plates in the center and thrust and locking nuts at the inner ends. Each blade has a small groove in one side, which forms a shoulder and a bearing surface for one side of the binder plate which is tightened by a screw. When the binder plates are tightened and the nuts at the inner ends are screwed tightly against the ends of

the blade, the latter are held rigidly in their slot. This tap is made by the Pratt & Whitney Co., Hartford, Conn.

The Murchey adjustable sizing tap is shown in Fig. 2. This particular tap has six chasers while the smaller sizes are provided with four chasers. These chasers may be adjusted either to maintain a standard size or to secure a tight or loose fitting thread by turning a central screw having a taper seat that engages the inner ends of the chasers. Different size chasers may be used in the holder. The range of each tap varies from $\frac{1}{4}$ inch in the $1\frac{1}{4}$ -inch size to $\frac{1}{2}$ inch in the 2-inch size and for larger taps.

Removal of Non-collapsing Taps from Holes. — The removal of a solid or non-collapsing tap from a hole in which a thread has been cut is usually done by backing the tap out of the hole, but in some cases the tap either passes completely through the tapped hole or else the work passes over the tap. Taps may be backed out of holes either by reversing the rotation of the spindle which holds and drives the tap or by reversing the part being tapped when the tap has advanced in the hole to whatever distance may be required. When the machine spindle is reversed, this may be effected either by means of the regular driving mechanism of the machine or by a special attachment applied to the tap driving spindle. If the tap remains stationary while tapping, as on turret lathes and many automatic screw machines, the work-spindle reverses for backing out the tap.

Another method of removing a tap that is common in screw machine practice does not require a reversal either of the tap or of the part being tapped. When cutting the thread, the tap revolves in the same direction as the work, but at a slower speed; consequently, the work tends to screw itself onto the tap just as though the tap were stationary and the work were revolving at a speed equal to the difference between the speed of the tap-spindle and the work-spindle. The opposite effect is obtained by revolving the tap faster than the work, which causes it to back out of the hole at a rate equal to the difference between the tap-spindle and work-spindle speeds. (This same method is applied to dies.) These changes of speed are controlled automatically.

For some tapping operations it is desirable to screw the tap clear through the tapped hole. There are three conditions under which this general method may be applied: If the tapping is being done on a vertical drilling machine and there is a clearance space beneath the tapped hole which is large enough to receive the tap, the latter is sometimes screwed completely through the hole and is then replaced in the spindle driving chuck for tapping the next hole. The chuck, in this case, is ordinarily in the form of a socket that fits the tap shank, so that the tap is free to fall as soon as it clears the thread formed in the work. When tapping small parts, such as nuts, another common method of removing the work without screwing it back over the tap is to allow successive parts tapped to pass onto



Fig. 3. "Namco" Collapsing Tap

the tap shank; when the shank is full the tap is taken out of the chuck and the work removed. To avoid removing the tap periodically in order to take off tapped parts such as nuts, an ingenious form of tap has been devised which has a curved shank and is so mounted in the tapping machine that parts like nuts pass over the shank so that the tapping can be done continuously. The practical application of these methods will be considered more in detail later in connection with tapping machines and attachments.

Advantages of Collapsing Taps.—The advantages of collapsing taps, as compared with the solid or non-collapsing type for machine tapping, are similar to the advantages of self-opening dies in contrast with the non-opening type. When a solid tap is removed by reversing either the tap or the work, the threads cut by the tap are often injured by the chips which

wedge in between the tool and the finished thread. The time wasted while the tap is backing out often greatly reduces the rate of production, and the power at the instant of reversal, as well as the strain on the machine used for tapping, may be considerable, especially when tapping comparatively large holes in tough material. On the other hand, solid taps cost less and are applicable for tapping numerous studs, screws, and bolt holes that are too small for taps of the collapsible type.

The collapsing of taps may be done either automatically by the engagement of a collar, gage-plate, or lever on the tap with the surface of the work or a fixed stop; the collapsing action

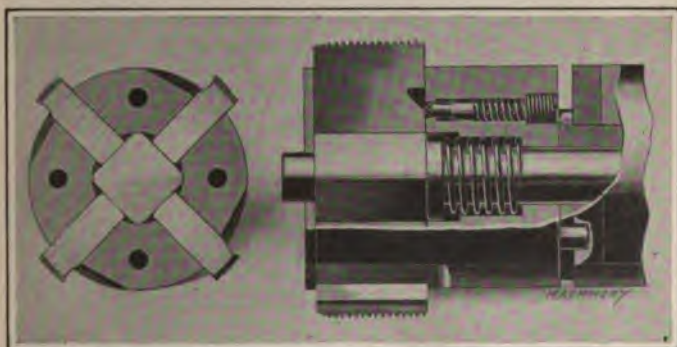

Fig. 4. Mechanism of "Namco" Collapsing Tap

may also occur soon after the travel of the turret-slide is discontinued as the result of relative motion between parts of the tap similar to that which occurs when a stop is used. Collapsing taps are similar in principle to self-opening dies, except that the action is reversed, the tap chasers moving inward in a radial direction instead of outward.

"Namco" Collapsing Tap. — The collapsing tap illustrated in Fig. 3 is of the type that collapses soon after the turret stops. The chasers are withdrawn from the thread in practically the same way that a gear would be thrown out of mesh. When the forward movement of the turret stops, the tap continues to cut until it advances sufficiently, due to the action of the chasers in the hole, to cause the driving pins to disengage; the chasers

then begin to revolve with the work and are at the same time automatically withdrawn from engagement with the thread. When the chasers are in position for cutting they are supported by the corners of a central stationary core piece. As soon as the driving pins are disengaged and that part of the tap carrying the chasers begins to turn around with the piece being tapped, the chasers move around opposite the flat sides of the central core so that they naturally disengage themselves from the work. The small conical pointed plunger at the rear of each chaser (see Fig. 4) is simply a safety device to prevent the chasers from

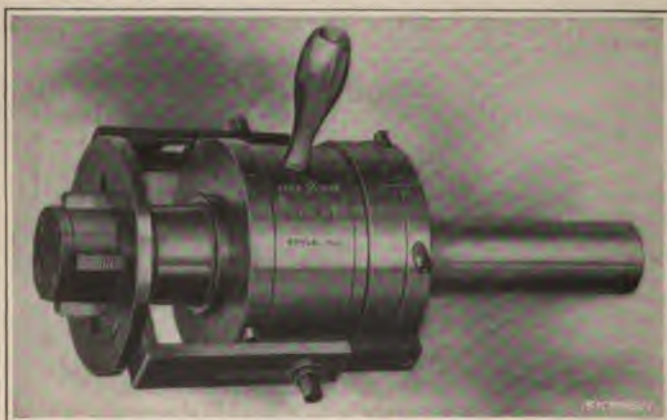

Fig. 5. Geometric Collapsing Tap

dropping back into contact with the thread. The end view shows the chasers in the collapsed position.

An important feature of this tap is the fact that the tap body and shank will pass through the tapped hole, so that the tap can be used for tapping exceptionally long holes or holes that are only slightly smaller than the diameter of an opening through which the tap must be inserted to reach its work. The tap may be adjusted for cutting either tight or loose fitting threads by simply turning two binding screws and revolving the square core in either direction. The adjustments for the maximum or minimum diameters are shown by a graduated scale on the hub of the tap. A "Namco" tap of the outside trip type is so arranged

that, when the tap has entered the hole to the required depth, the outer tripping ring strikes the face of the work, thus causing the chasers to be collapsed. The tap is reset by means of a lever. This tap is particularly adapted for pipe threads or short straight threads. The "Namco" tap is made by the National Acme Co., Cleveland, Ohio.

Geometric Collapsing Tap.— One design of collapsing tap made by the Geometric Tool Co., New Haven, Conn., is shown

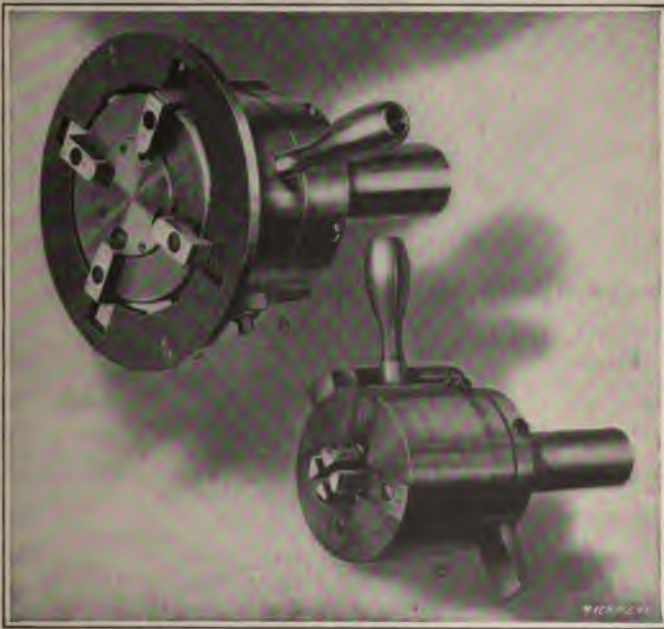

Fig. 6. Other Designs of Geometric Collapsing Taps

in Fig. 5. This particular tap (style NL) is made in sizes varying from 1 to 12 inches. The tap may be attached to a revolving spindle or to a turret. An adjustable gage controls the collapsing action by coming into contact with the work. The chasers are expanded by means of the handle shown projecting from one side of the tap body. Slight adjustments to compensate for wear may be made by means of micrometer adjusting screws. Another Geometric tap (style P) of a type intended especially for tap-

ping shallow holes and threads of fine pitch or flush to the bottom of a hole is shown at *A*, Fig. 6. This particular style of tap is furnished for cutting standard pipe threads from 4 to 10 inches, inclusive, and for tapping actual diameters varying from $4\frac{1}{2}$ to 11 inches when the threads are not coarser than eight per inch, and the depth of the hole does not exceed $1\frac{1}{2}$ inch. These taps are subject to more or less variation in design because of different working conditions. This tap has an end plate trip, as the illustration shows. The lever type of trip applied to the tap shown at *B* in Fig. 6 is particularly suited for certain classes

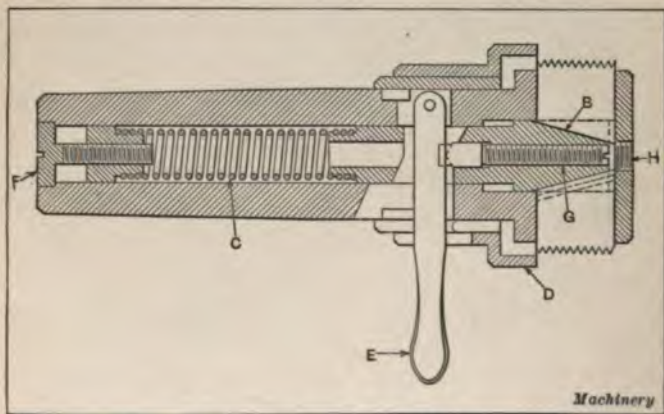

Fig. 7. Victor Collapsing Tap

of work. An adjustable screw-stop attached to the cross-slide of the machine engages the tripping lever and controls the point at which the collapsing action occurs. The Geometric collapsing tap may be fitted with a roughing and finishing attachment similar to that employed on the self-opening die-head, when tapping exceptionally accurate work. The tap chasers are adjusted outward for taking a light finishing cut by turning a small lever. None of the taps illustrated are equipped with this attachment.

Victor Collapsing Tap. — The sectional view, Fig. 7, illustrates the arrangement of collapsing taps made by the Victor Tool Co., Waynesboro, Pa., for diameters of 2 inches and larger. The chasers, which are inserted in radial slots in the body of the tap, bear against a hardened steel plunger or central plug *B*. This

plunger is ground to an angle of $14\frac{1}{2}$ degrees from the axis (29 degrees included angle) and the inner ends of the chasers are beveled to correspond. This plunger is attached to a closely wound tension spring *C*, which is elongated when the tap is set for cutting. The depth at which the tap collapses automatically is regulated by the trip-collar *D*, which can be adjusted for varying the tripping position. When this trip-collar strikes the face of the part being tapped, a latch is forced to release the tripping lever *E*, and then the tension spring immediately draws the plunger *B* back, thus permitting the chasers to recede along the

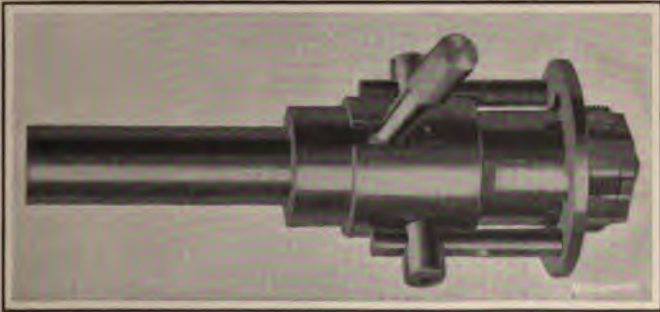

Fig. 8. Murchey Hand-lever Type of Collapsing Tap

angular surface of the plunger. The tap is reset in the cutting position by moving lever *E* forward to the position shown in the illustration, which forces the chasers outward and locks them in position. The tension on the spring may be regulated by the screw *F* at the rear of the tap shank. The size of the tap may be varied by means of a hardened set-screw *G* in the front end of plunger *B*. This screw has a very fine thread, so that minute adjustments may be obtained, and it is protected by the safety screw *H*. Collapsing taps that are less than 2 inches in diameter are similar to the design described, except that the adjustment for size is secured by changing the position of a threaded collar.

Murchey Collapsing Taps. — The collapsing tap shown in Fig. 8 is designated by the manufacturer (Murchey Machine & Tool

Co., Detroit, Mich.) as the "lever-handle" type, and it is intended for use on machines such as turret lathes, etc., where the tap is held stationary while the work revolves. This tap has a tripping ring which is adjustable and is set so as to come into contact with the face of the work when the hole has been tapped to the required depth. As soon as this tripping ring comes into contact with the work, the chasers automatically collapse so that the tap can be withdrawn rapidly. The chasers are reset in the working position by the lever seen projecting from the side of the tap body. The chasers are supported on an expanding bearing

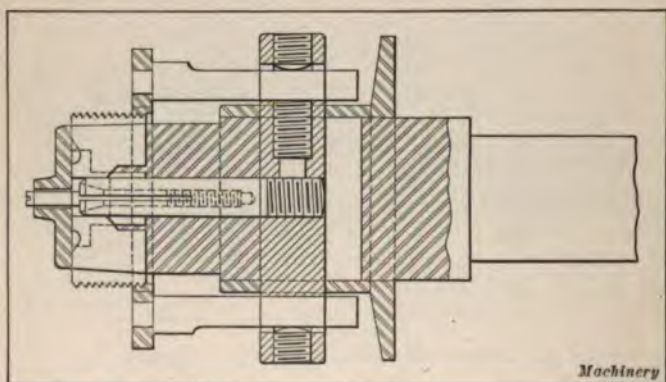

Fig. 9. Murchey Sliding-collar or Revolving Type of Collapsing Tap

that may be adjusted for obtaining a larger or smaller diameter by simply turning a screw.

A "sliding collar" or revolving type of collapsing tap is illustrated in Fig. 9. This tap has an adjusting tripping ring the same as the lever-handle design, but it is reset by means of a sliding collar instead of a lever. This collar, which is located next to the shank of the tap, comes into contact with a fixed stop on the machine when the tap is withdrawn, thus resetting the chasers in the working position.

M. E. C. Collapsing Tap. — A collapsing tap having chasers that operate with a rolling action is shown in Fig. 10. The four chasers are in the form of round bars except at the outer ends, where they are cut away to form clearance spaces in front of the

teeth. Each chaser bar has a lug that engages a radial slot in a chaser controlling ring or collar within the tap body. When this controlling ring is turned in one direction the chasers roll so as to move the cutting teeth inward, as when collapsing the tap. By turning the ring in the opposite direction, the chasers are returned to the working position and size. The controlling collar is held in place by a suitable stop while the tap is cutting. When the tap has entered the hole to the required depth, the tripping cap comes into contact with the work, and as the tap

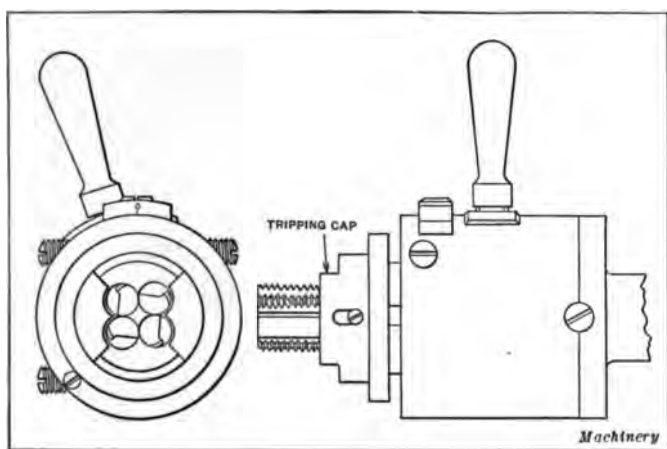

Fig. 10. M. E. C. Collapsing Tap

continues to advance, the controlling collar is disengaged. A spring then turns the collar quickly and withdraws the chasers. The tap is reset to the working position by means of the hand-lever shown projecting from the side. The distance that the chasers project beyond the tripping cap, or the depth to which a hole is tapped, is regulated by an adjustable screw in the shank of the tap, which serves to move the chasers in or out. This tap is the product of the Manufacturers Equipment Co., Chicago, Ill.

Resetting Collapsing Taps. — The method of resetting collapsing taps varies according to the construction of the tap and may depend, in some cases, upon the type of machine used for the tapping operations. Collapsing taps of the non-revolving class,

which are intended for use in turrets, etc., commonly have a lever projecting from the side which is used for resetting the tap after it has collapsed, as previously explained. This lever may be operated by hand, or the machine, if an automatic type, may be equipped with some form of projecting part arranged to engage the closing lever as the tap and turret-slide are withdrawn after the tapping operation. Some collapsing taps designed to revolve have a sliding flange or collar which engages a suitable collar or stop and serves to reset the tap.

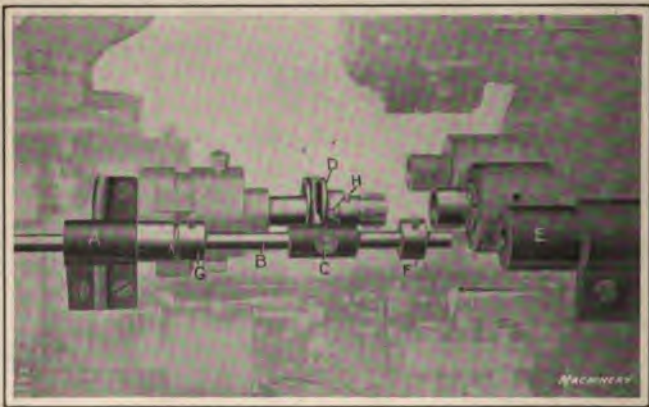

Fig. 11. Tap Resetting Attachment on Acme Multiple-spindle Automatic

The special tap resetting attachment for a "Namco" tap applied to an Acme multiple-spindle automatic is shown in Fig. 11. The tap, in this case, is arranged to revolve when cutting a thread. The bracket *A*, carrying shaft *B*, is bolted to the main tool-slide of the machine so that shaft *B* is parallel with the tap-spindle. Yoke *C* engages the spool or grooved collar *D*, which is free to slide on the tap proper. Stop *E* is bolted to the cylinder casing of the machine to terminate the travel of the tap. The amount of travel is controlled by the adjustment of collar *F* on rod *B*. When the tap is cutting, the forward travel of the tool-slide carries stop-collar *F* into contact with stop *E*, which is drilled to receive the projecting end of rod *B* and serves as a guide. When the work has been

tapped to the required depth, the forward travel of the tool-spindle is stopped and the chasers collapse as described in connection with the "Namco" tap illustrated in Fig. 3. As the tool-slide recedes from the work to allow the work-spindles of the machine to index for the next operation, a closing attachment operates in the following manner: The backward travel of shaft *B* is accelerated and yoke *C* engaging spool *D* is stopped by contact with collar *G*; as the tap proper continues to recede with the backward movement of the tool-

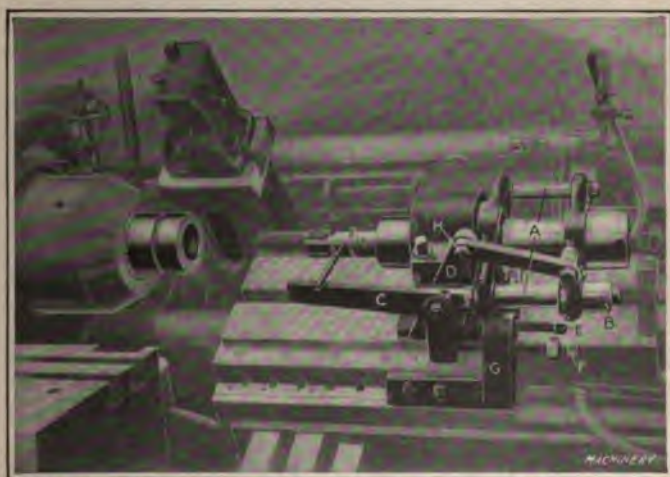

Fig. 12. Tap Resetting Attachment on Gridley Single-spindle Automatic

slide, spool *D* remains stationary, causing the resetting pin *H* to travel down the inclined cam surface shown, thus resetting the tap for the next operation.

The resetting attachment for the "Namco" tap, as applied to the Gridley single-spindle automatic, is shown in Fig. 12, and is similar to the mechanism used for self-opening dies. This attachment is bolted to the slide on the turret and consists of guide-rods *A*, a spring at *B* for starting the tap onto the work, a closing lever *C*, a stop-lever *D*, an adjusting screw *E* for the stop-lever, an adjusting screw *F* for the closing lever, and a stationary stop *G* bolted to the side of the turret. The

operation is as follows: When the turret is moved forward by the regular cam equipment of the machine and the tap is about to engage the work, the spring at *B*, controlled by stop-lever *D*, causes the tap to start cutting, the bracket shown traveling on guide-rods *A* for the length of the cut. When the tap has entered the hole to the required depth, stop-lever *D* ceases to hinge at fulcrum point *H*, thereby stopping the travel of the tap and causing it to trip or collapse. As the mechanism recedes, the adjusting screws *E* and *F* in bracket

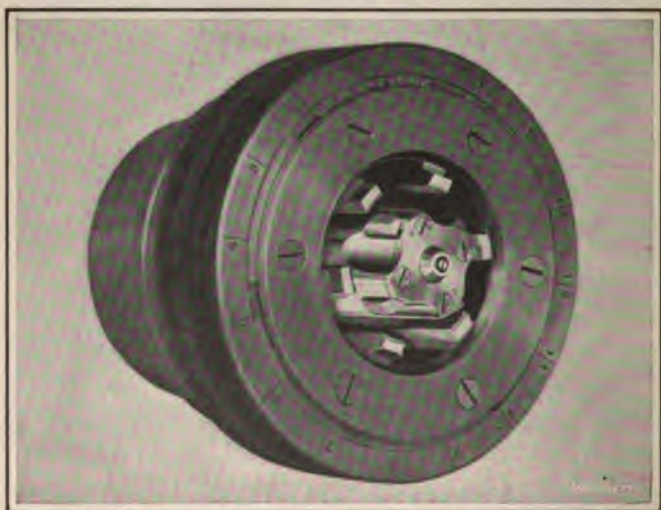

Fig. 13. Murchey Combination Tap and Die

G cause the closing lever to engage the handle of the tap and reset it for the next operation. When this tap is used on other machines, the mechanism may require more or less modification. When tapping deep holes, special equipment has been applied to allow the tap to cut to any required depth.

Combination Tap and Die.—Some internal and external threading operations can be performed to advantage by a combination tool which cuts both threads at the same time. For instance, the thread-cutting operations on some of the parts of shell fuses can be done with a combination tap and die of the

general design illustrated in Fig. 13, which is one of the developments of the Murchey Machine & Tool Co., Detroit, Mich. Fig. 14 shows two examples of the kinds of work for which this type of combination tool is adapted. It consists of a sizing tap which is placed within a die as the illustration shows. Both the tap and die are provided with means of adjustment for varying the diameter within certain limits. When a tool of this type is to be used for cutting internal and external threads of different pitch, the tap is so held that it is free to move longitudinally in order to compensate for the difference in rate at

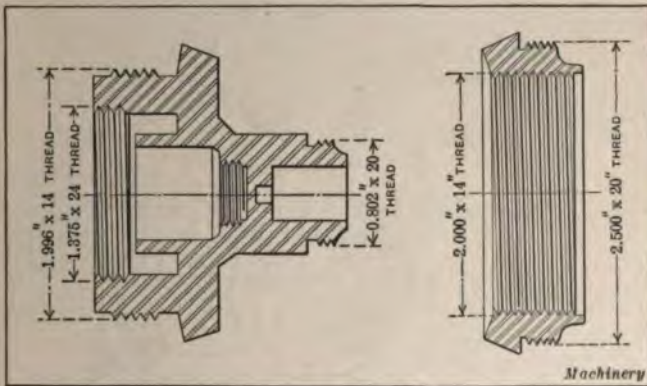

Fig. 14. Examples of Work for which Combination Tap and Die is Adapted

which the tap and die must advance. While this type of tool was developed especially for thread-cutting operations on fuse parts, obviously the same general type of tool may be applied to other classes of work.

Combination Tapping and Boring Tool. — Tools consisting of taps combined with boring and facing cutters have proved very efficient in some cases. Fig. 15 shows a combination tool of this type which is used for boring and reaming one hole, reaming and tapping a second hole, and chamfering and facing the surface at the outer end of the tapped hole. The illustration shows a sectional view of that part of the work (an automobile differential case) upon which the tool operates. The various cutting tools

are marked with capital letters, and small letters indicate just where each tool operates. The order of the operations is as follows: Cutter *A* bores hole *a* to a diameter of 4.351 inches; cutter *B* reams hole *b* to a diameter of 4.371 inches; cutter *C* reams hole *c* to a diameter of 4.5625 inches; cutter *D* cuts a 45-degree chamfer *d* at the edge of the hole *c*; and cutter *E* faces surface *e*. While this turning and facing is being done, the chasers of the tap are in a collapsed position. After the tool is withdrawn, the tap is expanded and then fed into the work for tapping hole *c*. Collar *F* engages a trip on the fixture which

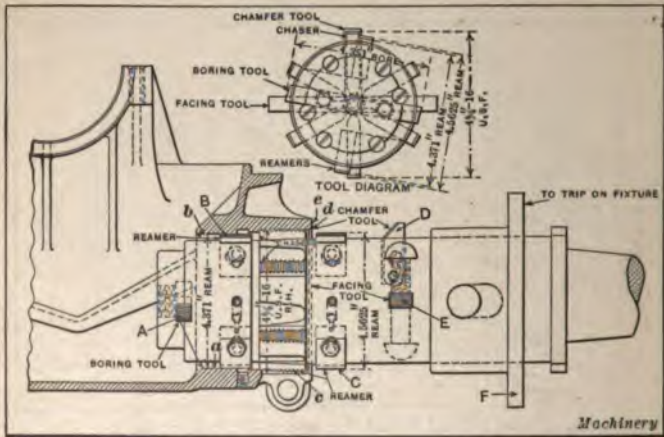

Fig. 15. Combination Boring, Reaming, Chamfering, Facing, and Tapping Tool for Machining Automobile Differential Case

causes the tap to be collapsed automatically. The use of this type of tool resulted in a considerable increase in production, since all of the operations are performed at one setting of the work.

Forms of Tap Flutes or Cutting Faces. — The location of the front cutting faces of taps, relative to the axis, or the shape of the flutes, in the case of solid taps, may affect decidedly the action of the tap. It is essential to have flutes that are large enough to provide room for the chips, but not so large as to weaken the tap excessively. The flutes should also be so formed and located relative to the axis of the tap that the front

cutting faces will have whatever rake may be needed to secure good cutting action. To obtain ideal results, taps should be fluted so that the angle of rake will be in accordance with the material to be tapped; while this can be done to some extent, a great many taps are intended for general work and must be made to suit average conditions as far as possible. In general, taps used principally or exclusively on steel should have positive rake, the plane of the cutting face being a little back of the tap center. The rake angle or the inclination of the teeth, with a radial line, usually varies from about 8 to 12 degrees. Solid taps are given this rake by using a cutter that is either convex, so as to under-cut or form a hook-shaped flute or cutting face, or a cutter having straight angular sides and a rounded point may be used, the amount of rake being controlled by the adjustment of the cutter relative to the axis of the tap blank. Various modifications of these two general types of tap fluting cutters are in use.

Plain convex flutes are shown at *A*, Fig. 16. The front and rear faces of the tap lands are similar. If the tap has to be backed out of the hole, the rear edges prevent chips from wedging between the teeth of the tap, which is an advantage, but, as the rear sides of the lands are the same as the front, there is likely to be some cutting or scraping action as the tap revolves backward when removing it from the hole. The amount of rake that can be obtained with a convex cutter is also limited, and by under-cutting the rear sides of the lands the tap is weakened.

The form of flute illustrated at *B*, Fig. 16, gives a tap greater strength than one fluted with a plain convex cutter. The front faces of the lands are under-cut to obtain positive rake, the same as if a convex cutter were used, but the rear sides are straight instead of following the curved arc shown dotted. This feature strengthens the tap, and the rear sides are also steep enough to prevent chips from wedging in between the teeth and thread. There is, however, likely to be more or less wedging of chips between the flutes and the tapped thread with any non-collapsing tap when rotation is reversed for backing the

tap out of the hole. The width w of the land of this kind of tap should equal one-half the width of the space or one-twelfth the tap circumference in the case of a four-fluted tap.

The form of flute shown at C, Fig. 16, has been used extensively with some modifications as to the radius of the bottom of the flute and the angle of rake in front of the lands. This flute is milled with a double-angle cutter and the tap may easily be given any amount of positive rake within practicable limits. If the rear sides of the lands have a gradual slope, as

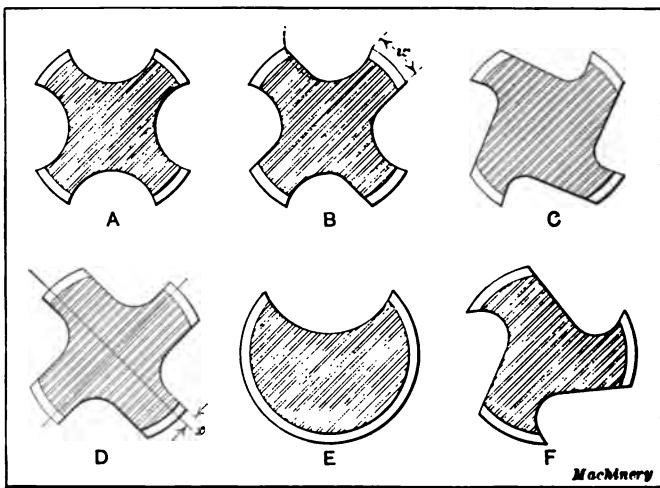

Fig. 16. Different Forms of Tap Flutes

shown in the illustration, difficulty is often caused by the wedging action of the chips, which may either mar the thread or result in breaking the tap. The flutes illustrated represent the shape obtained with a cutter having an angle of 30 degrees on one side of the center line and 55 degrees on the other. Some angular fluting cutters have an included angle of 90 degrees, with each cutting edge 45 degrees from the center line.

Rake of Tap Cutting Edges. — The amount of positive rake that a tap should have to work satisfactorily in steel should preferably be such that slightly curling chips will be produced. These chips should break up into short lengths and not be so

long as to jam tightly in the flute, which might occur if the tap had too much rake. On the contrary, insufficient rake prevents a free cutting action and the metal is pushed ahead of the teeth and compressed until in some cases the tap breaks. Taps that are hook-fluted, or provided with positive rake, cannot be used to advantage for tapping cast brass and cast iron, and either a radial cutting face or negative rake is preferable. Taps that are intended exclusively for brass generally have cutting edges that are ahead of the center, as illustrated at *D*, Fig. 16. The plane of the cutting face is usually ahead of a radial line a distance x varying from $\frac{1}{16}$ to $\frac{1}{10}$ of the tap diameter, which gives negative rake. The tap illustrated at *E* has been extensively used for tapping copper. As copper is such a tenacious material ordinary taps do not cut it satisfactorily. The tap shown at *E* has but one flute, so as to leave as much bearing surface as possible and prevent the tap from tearing the thread. Another form of tap intended for copper is illustrated at *F*. In this case the flutes are so shaped that the tap has considerable positive rake. If a commercial tap is used on copper, the form of flutes illustrated at *B* is preferable to the plain convex shape shown at *A*, because a tap for any tenacious material such as copper should not have lands that are under-cut on the rear side.

Chamfer on End of Tap. — The length of the chamfer on the leading end of the tap may depend almost entirely upon the class of work for which the tap is intended. If threads are to extend close to a shoulder or the bottom of a blind hole, the chamfer may be confined to the first annular row of teeth or even be omitted entirely, especially when tapping cast brass or some other material that is easily cut. When the tap can pass clear through the hole or a full thread close to the bottom of the hole is not necessary, it is preferable to chamfer several of the end teeth, the number of teeth often varying from four or five to ten or twelve. If the chamfer is too gradual or extends over too many teeth, the tap may not screw itself into the hole, but may act somewhat like a reamer and merely enlarge the hole as the teeth revolve without advancing along a helical path as when cutting properly. This is due to the fact that

each tooth cuts such a shallow groove that it does not offer sufficient bearing surface to force the following teeth to advance; consequently, they simply rotate in one position and cut away the metal like a reamer instead of forming a helical thread groove. It is important, however, to chamfer taps for through holes back as far as practicable, because less power is required to drive such taps, and, therefore, they are subjected to less torsional strain and are less likely to break. Repeated tests made by the Greenfield Tap & Die Corporation show that approximately 25 per cent more power is required

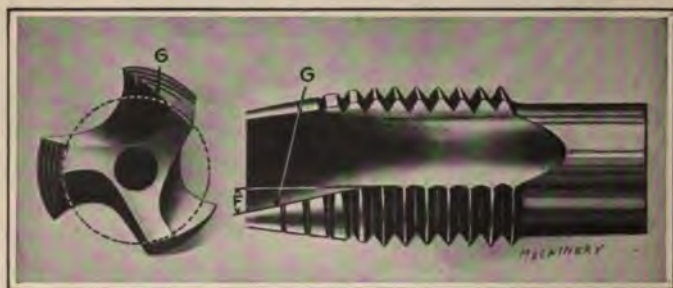

Fig. 17. "Gun" Tap having Cutting Edges on Chamfered End ground at an Angle to Axis for Deflecting Chips and causing them to curl out ahead of Tap

to drive a tap having a chamfer extending back over only four threads than one having a chamfer extending over six threads. The four-thread chamfer in the case of a four-fluted tap divides the work between sixteen teeth, whereas the six-thread chamfer divides it between twenty-four cutting teeth. The tap having the longer chamfer also has the advantage of producing a much smoother thread and cuts more closely to size.

An unusual form of tap is shown in Fig. 17. The chamfered edges are ground at an angle F to the axis so that they will cut with a shearing action. The object of this inclined cutting edge is to cause the chips to curl out ahead of the tap instead of collecting in and clogging the flutes, and for that reason the manufacturer (Greenfield Tap & Die Corporation) refers to it as a "gun tap," the name signifying that the tool shoots its

chips straight ahead in long curls. Because of this cutting action, two or three flutes which are comparatively shallow may be used, thus increasing the strength of the tap. All the cutting is done on the first few teeth and the rest of the teeth act as a lead-screw for guiding the tap. The grinding is done on the angular cutting edge instead of in the flutes. This tap is especially adapted for difficult conditions or the tapping of tough material.

Cause of Reaming Action. — The reaming action previously referred to and the failure of the tap to start or catch the thread is usually caused by the use of a tap drill that is too small rather than by an excessive amount of chamfer. In some cases, holes to be tapped are actually smaller in diameter than the root diameter of the thread, so that the end of the tap must ream out the hole. This additional work imposed on the tap prevents it from advancing along a helical path, because the increased resistance to this forward movement is so great that the teeth will not follow along the thread groove as they naturally tend to do, but simply revolve and cut away the metal like a reamer. Even if the tap should begin to advance after being forced partly through the nut, the thread formed in the remainder of the hole would be thin and weak.

Clearance or Relief for Tap Cutting Edges. — There are several ways of providing clearance for tap cutting edges so that they will cut freely. The teeth of taps intended for straight threaded holes may be backed off or relieved like the teeth of a form milling cutter, as shown at *A*, Fig. 18. In this case, the teeth are relieved on the top and angular sides and also at the root. A tap relieved in this way will cut freely, but it has been objected to on the ground that there is not sufficient support while cutting to produce round, smooth holes; moreover, there will be a reduction in diameter as soon as the front cutting faces are ground for sharpening the tap. To secure better support than is obtained from the points of the teeth relieved as shown at *A*, taps for threads having flat tops, like the U. S. standard, have been made with teeth that are concentric on the outside but relieved on the angular sides. While such taps cut freely

and are well supported by the concentric teeth, both the pitch diameter and the width of flat are reduced by repeated grinding.

The disadvantages of relieving straight taps as previously described led to the introduction of a tool that was given clearance not by relieving the teeth from front to back, but by making the tap a little larger in diameter on the leading end (say, 0.001 to 0.002 inch) than at the shank end. The effect of this slight back taper is to make the tool cut more freely, and a great many taps have been given clearance in this way. Taps without eccentric relief (except on the chamfered end) are pref-

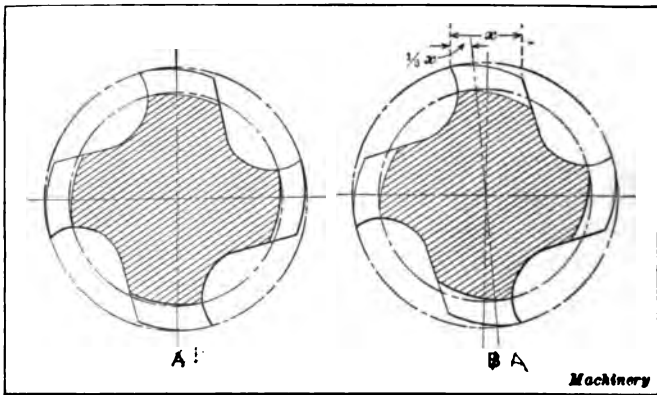

Fig. 18. (A) Tap relieved both on Top and in Angle of Thread.
(B) Form of Relief known as "Con-eccentric"

erable for use on automatic screw machines of the type which reverse for backing out the tool, because chips are less likely to wedge between the teeth and mar the thread or break the tap.

Another method, which is regarded by some as the best form of relief, is illustrated at *B*, Fig. 18. This is known as the "con-eccentric" relief because the teeth are concentric for a distance equal to one-third the width of the land, and the rest of the tooth is eccentrically relieved. The object of this form of relief is to provide enough clearance to make the tap cut freely, and at the same time give adequate supporting surface. The tap teeth can also be ground back for sharpening without changing the shape of the cutting edge or the tap diam-

eter. The top of the thread is relieved across the entire width of the land on the chamfered part of the tap to secure a keen cutting edge. The chamfered end is also given greater relief than the straight part to improve the cutting qualities. The angular sides of the teeth on the chamfered part have the regular relief.

Taps for cutting threads in tapered holes must have teeth relieved across the entire width of the land, both on the top and angular sides. If a tapered tap were not relieved in this way, the rear ends or "heels" of the teeth would be higher up on the taper than the cutting edges, owing to the inclination of the teeth relative to the tap axis. In other words, the rear end of any tooth would coincide with a larger circular section of the tap than the cutting edge; consequently, the cutting edge would not form a space large enough for the rear end of the tooth.

Diameter of Hole before Tapping. — The diameters of holes to be tapped may seriously affect the tapping speed, the power required for tapping, the loss of taps as the result of breakage, and the quality of the work. The hole should be somewhat larger than the root diameter of the thread, the amount depending to a certain extent upon the class of work and the kind of material. For ordinary manufacturing, from 75 to 80 per cent of the standard thread depth is sufficient, and, for some classes of work, not more than 50 per cent of the thread depth is required. Tests have demonstrated that a U. S. standard thread cut to one-half the standard depth in an ordinary cold-punched nut will not strip. The tops of the bolt threads also resist the stress, and it is the bolt that breaks.

Tests made by the Greenfield Tap & Die Corporation have demonstrated that a full depth of thread in a nut is practically no stronger than a 75 per cent depth of thread; furthermore, a thread depth equivalent to 75 per cent of the standard is only 20 per cent stronger than a thread of 50 per cent depth. As the thread depth increases beyond 75 per cent, the power required to drive the tap rapidly increases as the full depth of thread is approached. Soft tough material, such as Norway

iron, drawn aluminum, copper, etc., should be drilled larger for tapping than hard crystalline materials, such as cast metals. If the holes in the soft tough materials are too small, the tops of the threads will be torn off when tapping, thus decreasing the effective thread depth. When a larger tap drill is used, the tapping action tends to draw the metal toward the top of the thread and increase the effective depth, especially after the tap has been lightly dulled.

If, for any reason, a full depth of thread is required, serial taps should be used. Taps of this kind progressively increase in diameter from the first to the last tap in a set in order to distribute the work more evenly between them. In general, tap drills giving a 75 per cent depth of thread are recommended. As commercial drill sizes will not always be just right, the next larger commercial size will give satisfactory results. The proper selection of tap drills is very important, and if properly attended to may result in a great reduction in the breakage of taps. The diameter of tap drills for U. S. standard or V-threads may be determined by the following formula, which is intended for a 75 per cent thread depth.

$$\text{Tap drill diameter} = T - 0.75 \times 2 D,$$

in which T = external diameter of tap or thread;

D = depth of thread.

The depth of a U. S. standard thread = $0.6495 \times$ pitch of thread, and the depth of a sharp V-thread = $0.866 \times$ pitch.

Tapping Square Threads. — While the Acme screw thread has replaced the square thread to a large extent because it is stronger and more easily cut, square threads are still of sufficient importance to merit some attention; moreover, those who are responsible for producing good square threads are not always in a position to substitute the superior Acme form. A satisfactory method of cutting square threads by means of taps is to form the threads by a progressive cutting action. This method, which may not be necessary for very fine pitches or comparatively rough threads, involves the use of a set of taps varying in size so as to distribute the work properly. For the finer pitches

there may be two taps in a set or as many as four or five, if the pitch is relatively coarse. Each tap should have a pilot or extension beyond the chamfered end, as this steadies it and improves its cutting qualities. The pilot of the first tap of the series is simply a smooth cylindrical end from 0.003 to 0.005 inch smaller than the hole to be tapped. The pilots of the following taps have teeth and should be of the same diameter as the body of the preceding tap. It is also advisable to have the teeth in the different taps of a set increase progressively in width. For instance, the teeth of the first tap of a set may have a width of, say, 0.247 inch; the teeth of the second, a width of 0.250 inch; and the width of the finishing tap, 0.253 inch. If the outside diameter of the finishing tap is 1.5 inch, the two preceding taps might have diameters of, say, 1.420 and 1.250 inch, respectively. When such taps are used, the thread groove is gradually made deeper or larger in diameter and wider, so that the final tap of a set serves to take a finishing cut over the entire surface of the thread groove, which is given a smooth finish. If the taps of a set increase in diameter but do not have teeth which progressively increase in width, the sides of the thread groove will not be finished as smoothly. The flutes of square-threaded taps should be at right angles to the cutting teeth in order to improve the cutting qualities, particularly if the taps are intended for coarse pitches and must cut away considerable metal. The teeth on the chamfered part of all the taps in a set should be relieved or backed off on top. If square-threaded taps are to be used for machine tapping, the teeth of the chamfered part should be relieved on the sides as well as on top.

Lead and Diameter Errors in Tapped Holes.— In order to secure accurate fits between screws and tapped holes, it is, of course, necessary to guard against inaccuracy both when tapping the hole and when cutting the external screw thread that is to enter the hole. While this is quite obvious, the relationship between external and internal screw threads is often disregarded, although the direct cause of many thread troubles. When fitting plain cylindrical parts in holes, the manufacturing problem is relatively simple, since the quality of fit usually depends

simply upon the diameter and finish, but in the case of screw threads, the accuracy and quality of the fit may be decidedly affected either by the lead of the thread or by its shape, in either the screw or the nut, as well as by the respective diameters of the screw and nut. Another feature of the screw thread is that errors are not always apparent at first, as, for example, when a screw seems to fit tightly but has a poor bearing in a nut or tapped hole because of a lead error.

The errors in screw threads produced either by tapping, by means of dies, or by some other method may be due to inaccuracy in the tool or the conditions under which the tool is used. Whatever the method or conditions, it is impossible to eliminate all error, and especially where the error — as in the case of screw threads — may be in the lead of the thread, the pitch diameter, the sectional shape of the thread, or the difference between the curvature of the thread and a true helix. In order to allow for these errors, which may be very small if considered singly but serious when combined, it is essential to adopt limits or tolerances between the threaded parts. This question of limits is difficult to deal with, particularly in a general discussion of the subject, since a suitable limit for one grade of work might be entirely too large or small for other threaded parts requiring greater or less accuracy. In general, maximum and minimum pitch diameters should be adopted for both taps and screws. The maximum pitch diameters of the screw threads should be slightly less than the minimum pitch diameters of the taps to allow the largest screw to enter the smallest hole, although if the two sizes were exactly the same, there might be no difficulty in assembling, because taps, as a rule, cut a certain amount over size, the amount varying according to the conditions to be referred to later.

In buying taps some manufacturers specify very small limits when the required degree of accuracy in threaded parts could be obtained with ordinary commercial taps if sufficient care were taken in their use and in making the screws which are to enter the tapped holes. While an accurate fit between threaded parts depends upon both the tap and the screw, some

users of taps forget that the screw may be at fault. This point is illustrated by the experiences of all tap manufacturers. Taps made for customers who specify very close limits of accuracy are frequently condemned as inaccurate, when the screws inserted in the tapped holes are the cause of the trouble, due, in many cases, to an error in lead. It is evident that little is to be gained by using high-priced taps that are made unusually accurate by employing special methods, if little or no attention is given to the limits of error in the screw; in fact, so far as pitch diameter is concerned, it is usually easier to control the diameters of the screws than the diameters of tapped holes, although with the adjustable taps now available extremely accurate work may be obtained, and holes in duplicate parts may be held to a standard size within small limits.

Many taps, particularly when used in a machine, tend to cut over size. This slight enlargement of the hole may be the fault of the tap or it may be caused by the method of holding it; the size of the hole before tapping is also frequently the cause of inaccurate work. If the threaded part of a solid tap is warped or bent slightly by the hardening operation, this will cause it to cut large, the error increasing as the length or depth of the tapped hole increases, up to the full length of the tap body. When taps are made of steel that is not properly rolled or annealed they may shrink unevenly in hardening or lose their circular form. If the teeth of an evenly fluted tap do not lie in a circular path, the tap will chatter and cut over size. A tapped hole that is too large may also be caused by the crowding of the metal resulting from passing a tap through a hole that is too small. Errors may also be due to excessive clearance or rake on the chamfered part of the tap, uneven chamfering on the different lands, excessive under-cutting in the tap flutes, or too much relief in the thread angle. Lack of alignment between the tap and work is frequently the cause of tapping holes that are too large and tapering. The extent to which errors from lack of alignment may be reduced, if they are not eliminated entirely, by the use of floating tap-holders depends upon the design of the tap-holder and the amount of alignment error.

By studying the different causes of error mentioned, tapping troubles that are the direct result of one or a combination of these causes may be greatly reduced or eliminated, and holes may be tapped accurately enough for ordinary commercial requirements without purchasing taps made to order and within specified limits of accuracy which require unusual and unnecessary refinement in their manufacture.

Speeds for Tapping. — The speeds for tapping vary between 15 and 30 feet per minute, according to common practice, these figures representing the surface or peripheral speed of the tap. When tapping cast iron, drop-forgings, or tough alloy steels, a surface speed of about 18 or 20 feet per minute is common. For tapping the softer grades of steel, such as Bessemer, open-hearth, screw stock, etc., the speed is generally increased to 20 or 25 feet per minute and may be higher under favorable conditions. In the case of tool steel, the speed may be reduced to 10 or 12 feet per minute. Speeds for tapping brass are, as a rule, several times as fast as speeds for cast iron or steel, there being a wide variation owing to the difference in the composition of alloys designated as brass. While taps are frequently operated at approximately the same speed as dies, the speed is usually somewhat less for tapping, partly because taps, as a class, do not discharge chips as readily as dies nor cut as freely; moreover, cooling compounds or oil may, as a rule, be applied more effectively to dies than to taps. In most shops where tapping is done, the speeds in feet per minute are not known. In many of these shops, it has been demonstrated by actual practice — which may in some cases extend over a long period — that, if the driving belt of the machine is on a certain step of the cone-pulley or the speed controlling levers are set in a certain position, the tap will be driven at the proper speed. It is not considered necessary to determine the speed in feet per minute, or even the revolutions per minute, which suggests an important point regarding all speed and feed data, namely, that at best they are only guides, and that the correct speed for a given tap, material, and other conditions affecting the speed, should, in each case, be determined by actual tests.

CHAPTER VII

DIE- AND TAP-HOLDERS AND REVERSING CHUCKS

DIE-HOLDERS may be arranged to hold the die rigidly or to permit either a longitudinal movement or a combined longitudinal and universal "floating" movement. Many of the die-holders used on machine tools or in connection with power-driven threading operations allow the die a limited amount of motion in the direction of its axis, so that it will be free to follow its own lead and will not be retarded by a backward pull of the tool-slide to which it may be attached. For instance, when cutting a thread with a die in a hand-operated turret lathe, the turret-slide is moved up until the die has started on the work. If the die-holder has longitudinal motion, the turret can lag behind somewhat without interfering with the forward motion of the die, which simply has to overcome the friction of the driving pins or keys of the die-holder as it screws itself onto the work. If the turret were not shifted along periodically when cutting a long screw, the lost motion in the holder would soon all be taken up and then the die would have to drag the turret-slide. This extra load might seriously impair the finish and accuracy of the screw thread. When the machine is of the automatic type, the cam operating the turret-slide is generally designed to start the die on the work and then the slide is allowed to travel a little slower than the die which governs its own motion independently. If the cam were laid out to control the motion of the die positively, any variation between the motion of the die and the pitch of the chaser teeth would affect the thread being cut.

Some die-holders are arranged to give the die a free floating movement in a direction perpendicular to the axis, so that, if the part to be threaded is not exactly in line with the die, the latter can center itself relative to the axis of the work and cut a concentric thread on it. While every holder having the axial

motion also has some lateral play, this is very slight in some holders and is a special feature in others. A lateral or universal float is especially desirable for dies used on parts that are chucked either by hand or from a magazine attachment for the threading operation. This floating motion is found on holders for both non-opening and self-opening dies.

The amount of longitudinal movement or float that a die-holder should have may depend upon the type of machine on which it is used. If the die is used on a hand-operated screw machine or turret lathe, or a single-spindle automatic screw machine, the floating movement may not be over $\frac{1}{4}$ or $\frac{1}{2}$ inch, the amount varying somewhat according to the size of the die-head. If the die is applied to a multiple-spindle automatic screw machine, considerably more floating movement may be necessary; in fact, the die, in some cases, may be attached to a telescoping sleeve arranged to give it a lengthwise movement of several inches, so that the die is enabled to move considerably in advance of other tools in the turret that may not have to move in so far from the end of the work.

Releasing and Non-releasing Die-holders. — The die-holders used for solid or non-opening dies may be of the rigid type, the floating non-releasing type, or the releasing type. For turret lathe and automatic screw machine work, the non-releasing type, which is free to move in a lengthwise direction a limited amount, is used extensively, although the releasing design is preferable under certain conditions. With this type the die is released or is not held against rotation after the thread has been cut to the required length. When the forward motion of the turret-slide discontinues, the rotation of the screw thread draws one section of the die-holder farther forward until the driving connection between the two sections disengages; the die then continues to revolve with the work as long as the latter continues to run forward. When the spindle is reversed the die starts to rotate backward with it, but this reverse movement is stopped automatically by the die-holder, and the stationary die is then backed off the screw as the spindle continues its reverse rotation.

The releasing type of die-holder (which is intended only for

non-opening dies) is used when it is necessary to govern closely the length of the thread, as, for example, when cutting a thread close to a shoulder. If the reversal of the machine is controlled by the operator, as in a hand screw machine, a releasing die-holder should be used, because, if the machine is not reversed at the instant a die of the non-opening type reaches the limit of its forward travel, the thread may be stripped or the die broken when attempting to cut close to a shoulder. When the releasing type of holder is applied to the threading spindle of a multiple-spindle automatic screw machine, if the threading operation is

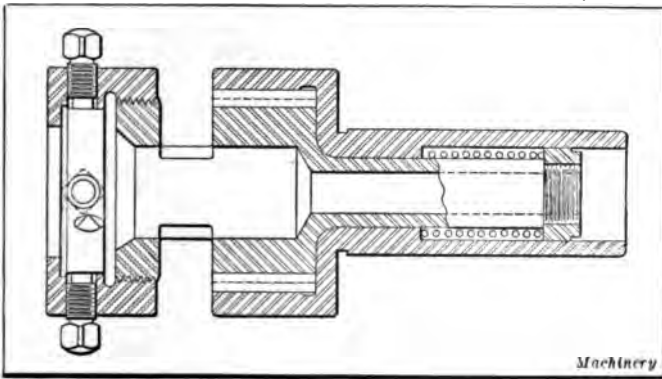

Fig. 1. Brown & Sharpe Die-holder of Non-releasing Type

completed before the other operations, the releasing device permits the die to revolve loosely until all the operations are completed.

The non-releasing type of die-holder is used for most of the thread cutting done on Brown & Sharpe automatic screw machines with non-opening dies. One design is shown in Fig. 1. The arrangement is such that the part to which the die is attached can move in a lengthwise direction relative to the shank. The releasing type is sometimes used to avoid having a narrow or pointed lobe on the cam controlling the thread-cutting operation. In some cases a cam that is laid out for the non-releasing type of holder has a thin, sharp threading lobe, but, by substituting the releasing type, a certain amount of dwell is obtained, so that the top of the cam lobe can be made wider.

Designs of Releasing Die-holders.—A simple form of releasing holder is shown at *A* in Fig. 2. The holder *a* has a shank *c* which passes through the sleeve *b*. This sleeve is held in the turret. When the die is cutting, the holder *a* is prevented from rotating with the work by the engagement of lugs *d* and *e*. When these lugs separate at the end of the cut, the die revolves

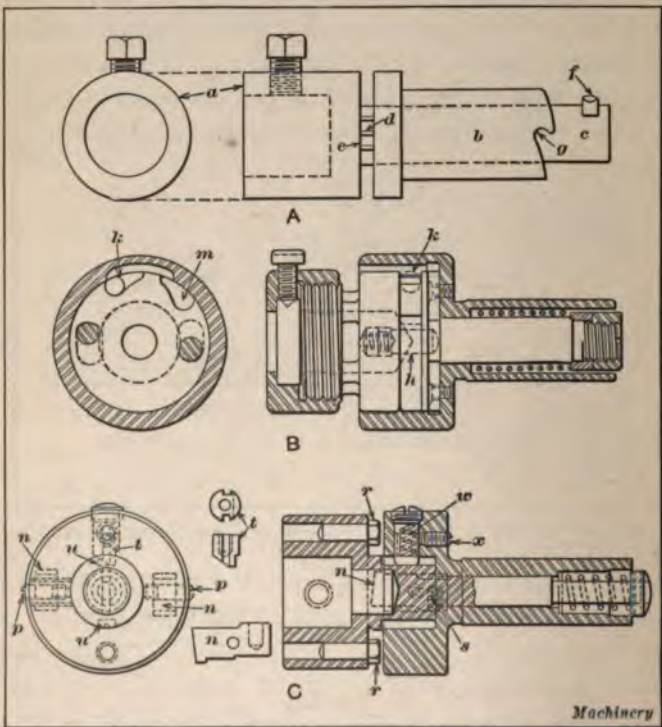

Fig. 2. Three Designs of Releasing Die-holders for Holding Non-opening Dies

with the work until the rotation is reversed; then pin *f*, as it revolves with shank *c*, engages notch *g* as the turret-slide is returned, and stops further rotation of the die, which is backed off the threaded section.

The holder illustrated at *B* operates on the same general principle as the one just described, although the construction is quite different. The driving connection between the two

main sections of the holder is through the pins *h*. When the turret-slide stops and the die-holder is drawn forward, these pins *h* are disengaged, thus releasing the die. As soon as the work-spindle reverses, a ball *k* slides out of the deep part of the pocket in which it normally rests, thus locking the two main sections together while the die is being removed. The ball is inserted in pocket *m* when the die-holder is used for cutting left-hand threads.

The releasing die-holder shown at *C*, Fig. 2, is known by the manufacturer (the Cleveland Automatic Machine Co.) as the "silent" type, because the driving members are so arranged that they will not strike against each other after being disengaged. The main part of the die-holder, which is held in the turret, carries two bevel-ended driving lugs *n*, which are mounted upon pins *p*, so that they are free to swivel. These driving lugs engage pins *r* in the die-holder proper; when the latter is drawn forward at the end of the cut or after the turret-slide stops moving, lugs *n*, acted upon by springs *s*, swivel until the beveled ends are practically in a plane at right angles to the axis of the holder. This swiveling movement provides clearance between lugs *n* and pins *r* so that the parts cannot strike against each other while the die is revolving with the work. When the spindle reverses, the beveled plunger *t* drops into slot *u* and holds the die stationary. This plunger is backed up by spring *w*. To change this die-holder for cutting left-hand threads, the driving lugs *n* are turned over, thus reversing the position of the straight driving side. The plunger *t*, which is held in position by the end of screw *x*, is also reversed.

Methods of Holding and Driving Taps. — The method of holding and driving a tap may vary according to the type of machine used for tapping, the kind of tap, or the class of work. The tap-holder may be designed to hold the tap rigidly or to allow it to slip or stop in case the resistance to tapping becomes excessive. Tap-holders may also be arranged to provide a certain amount of lost motion or floating movement either in a longitudinal or a lateral direction the same as die-holders. The object of the longitudinal movement is to allow the tap to ad-

vance according to its own lead and independently of the advance movement of the driving spindle or slide to which it may be attached. The lateral floating movement is to compensate for any lack of alignment between the hole being tapped and the tap-driving spindle or holder, although some taps as well as dies that are supposed to have this self-adjusting feature do not line up properly with a hole that is out of line because of the frictional resistance of the driving pins or lugs, which prevents a free floating movement. Tap-holders for solid or non-collapsing taps may be of the releasing or non-releasing type, as de-

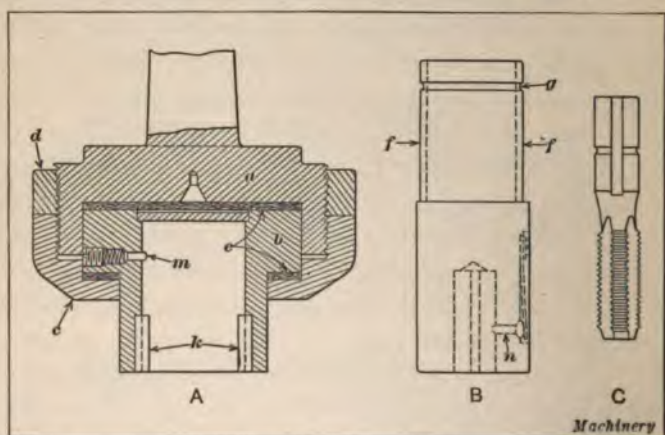

Fig. 3. Beaman & Smith Frictional or Safety Tap-holder

scribed later. Another type of tap-holder is designed especially to permit inserting or removing taps easily and quickly. There are also tap-holding chucks or tapping attachments that are equipped with a mechanism for reversing the rotation of a non-collapsing tap to back it out of a hole. Many tap-holders are designed along the same general lines as die-holders.

Frictional Tapping Chucks.— In order to prevent breaking power-driven taps when an unusual resistance is encountered, they are sometimes held in frictional chucks arranged to allow the tool to slip before it is strained to the breaking point. The need for a frictional drive may arise when the tap strikes the bottom of a blind hole, or if the hole before tapping is not large

enough, the tap may be subjected to excessive strains. A design of frictional holder that is intended for driving both drills and taps is shown at *A* in Fig. 3. This holder (which is made by the Beaman & Smith Co., Providence, R. I.) has a shank *a*, a friction socket *b* which receives the tap-holder, a cap-nut *c*, and a lock-nut *d*. Fiber washers *e* are placed on each side of the friction socket flange and nut *c* is tightened until there is just enough friction between parts *a* and *b* to drive the tap under normal conditions. If the tap should encounter unusual resistance or strike the bottom of a blind hole, it will slip instead of break, provided nut *c* is not set up too tight.

With the frictional tapping collet illustrated in Fig. 4, the frictional resistance is obtained by means of a tapered plug *A*,

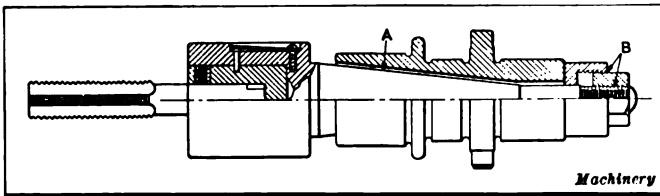

Fig. 4. "Wizard" Friction-drive Tap-holder

which is drawn into a fiber lined hole of corresponding taper by a differential screw *B*. As the illustration shows, the nut for making the adjustment is threaded internally and externally. These threads vary in pitch so that a sensitive and powerful adjustment is obtained. This frictional collet (which is the product of the McCrosky Reamer Co., Meadville, Pa.) is used in the quick-change collet chuck illustrated in Fig. 9 and described later. By supplying collets for the different taps that may be required in succession on the same job, each size tap may have its own friction properly adjusted, in order to avoid readjusting the friction for different sizes.

The Woodstock safety tapping chuck (made by Peter Bros. Mfg. Co., Algonquin, Ill.) is arranged to hold the tap by the square end of the shank only, between the jaws *A* (see Fig. 5). These jaws are located in a slot in the friction cone *B*, which prevents them from turning except with the cone. *A*

circular projection on part *C* fits into the slot of cone *B* and forces the jaws downward for gripping the square end of the tap shank when the outer shell of the chuck is screwed up or tightened. The tap is prevented from pulling out by a small pin in one of the jaws, which engages a catch or notch formed on the square end of the tap. Between part *C*, which is called the "rocker," and the stem or shank *D*, there is a fiber friction disk *E*. This fiber disk forms part of the frictional surface through which the tap is driven. In addition, there is a conical friction surface at *F* formed of fiber contained within a steel case surrounding the cone *B*. This conical cup is prevented from

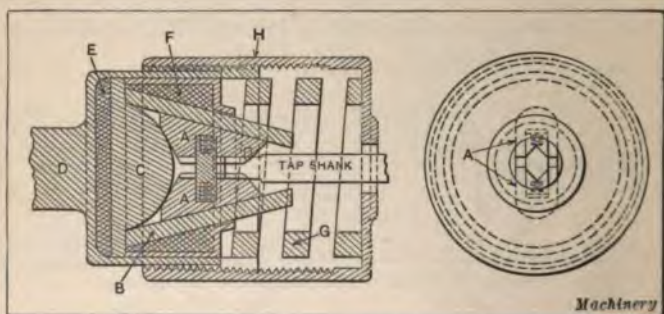

Fig. 5. Woodstock Safety Tapping Chuck

turning with cone *B* when the latter slips, by two pins that engage slots in the inner shell of the chuck body. The cup *F* is held in contact with cone *B* by spring *G*, the tension of which is regulated by screwing the outer shell *H* in one direction or the other. Graduation lines on the body of the chuck serve as a guide in securing the proper amount of frictional resistance. The graduations are for ordinary tapping operations in steel. When tapping exceptionally tough material like nickel steel, it might be necessary to screw the shell, say, half a revolution beyond the graduating line, whereas for tapping cast iron, the shell might not be advanced to the graduating line within half a revolution.

Releasing and Non-releasing Tap-holders. — The tap-holders for non-collapsing taps are made in the releasing or non-releasing

type the same as die-holders. The non-releasing holder should preferably have enough lengthwise floating movement to allow the tap to follow its own lead, but the tap is at all times prevented from revolving. A simple design of non-releasing holder which is used on many Brown & Sharpe automatic screw machines is shown in Fig. 6. This consists of two main parts *A* and *B*. The outer part *A* is held in the turret, whereas the tap is held in the inner part *B*. The latter is free to move a limited amount in a lengthwise direction against the tension of spring *C*.

With the releasing type of holder the tap is prevented from rotating until the tapping operation is completed, when it is

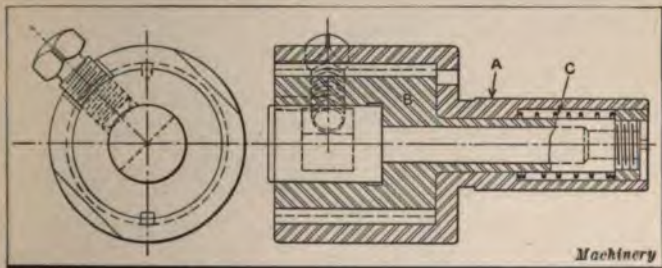

Fig. 6. Tap-holder of Draw-out Non-releasing Type

released. One of the Errington releasing holders is illustrated in Fig. 7. The shank of the holder passes through a sleeve *A*, having clutch teeth formed on each end. When the tap is entering a hole, the clutch pins at *B* are in engagement with the sleeve and the tap is prevented from rotating. When the forward movement of the turret-slide is arrested by stops previously set, the tap continues to advance until the pins at *B* are disengaged from the clutch sleeve, and then the tap revolves idly with the work. As soon as the work-spindle is reversed and the turret with sleeve *A* is moved in the opposite direction, the clutch pins *C* come into engagement with the sleeve and hold the tap stationary while it is being backed out of the tapped hole. This particular holder is provided with a friction drive, which is adjusted to slip and prevent breaking the tap in case the latter is subjected to excessive stresses or comes against the bottom of a hole. There are

various other designs of tap-holders in both non-releasing and releasing types, many of which are similar to die-holders.

In many shops it is the practice to use non-releasing holders on automatic screw machines, and the releasing type on turret lathes or screw machines which may be reversed by hand, especially if a thread is to be cut close to a shoulder. The reason for using a releasing holder on a machine that is reversed by hand is to prevent breaking the tap by allowing it to revolve with the work after being fed in to a predetermined depth. If the holder were non-releasing and the machine were not reversing at exactly the right time, the tap might be broken or the thread damaged.

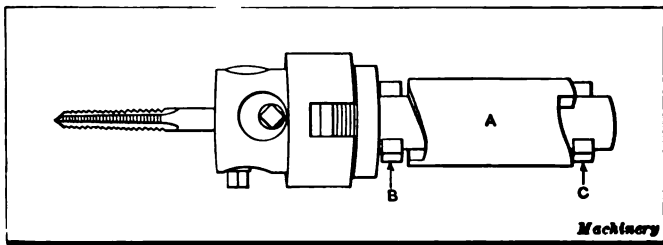

Fig. 7. Errington Friction Tap-holder of Releasing Type

Tap-holders of Quick-change Type. — When tapping operations are performed on drilling machines in connection with drilling operations, chucks are often used that are arranged for holding either drills, taps or other tools interchangeably, and these chucks or holders are so designed that a drill may be quickly replaced by a tap, or *vice versa*. Whether it is advisable to drill all holes to be tapped and then rehandle the work for tapping may depend upon the size of the casting or forging and the relation between the tapping and other operations. When tapping duplicate pieces on a drilling machine that are too heavy to adjust or center themselves with the tap, or when the work is clamped in position, it is common practice to drill, tap, and possibly insert a stud in the tapped hole, in one series of operations, instead of rehandling the parts for tapping. It is for operations of this kind that the quick-change chucks, collets, or holders for drills, taps, etc., are of especial value.

The holder or socket illustrated at *B*, Fig. 3, is used in connection with the Beaman & Smith friction chuck shown at *A*. This holder is splined at *f* on each side, and these splines engage keys *k*. The small spring-pin *m* engages groove *g* on the holder and prevents the latter from falling out of the chuck when there is no upward pressure. The tap *C* is also driven by side keys and is prevented from dropping out by the spring pin *n*. The drill sockets, which are also inserted in this friction chuck, have a standard taper hole for receiving drill shanks.

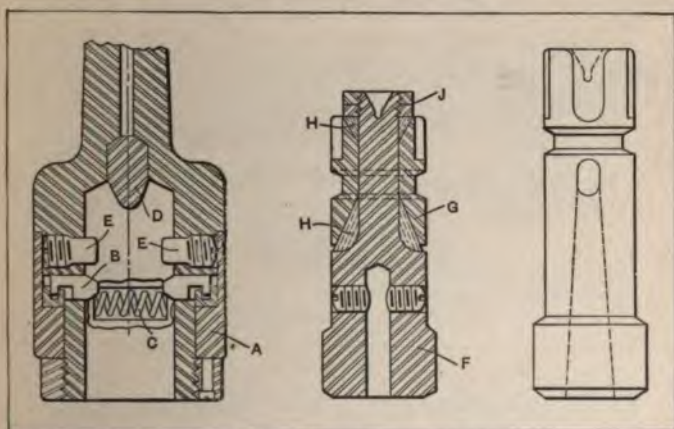

Fig. 8. Horton Quick-change Collet Chuck and Collets

The quick-change collet chuck illustrated in Fig. 8 is so arranged that either the tap collet or drill collet can be inserted by simply grasping the knurled sleeve of the chuck and holding it back against the rotation of the spindle as the collet is pushed into place. When the sleeve *A* is held against rotation, the retaining dogs *B* are withdrawn by the action of cam surfaces. As the collet is pushed up into the chuck it is centered by the tool-steel plug *D*, which engages a conical shaped center formed in the end of the collet. The studs *E* come into contact with flat surfaces near the end of the collet and provide a positive drive. As soon as sleeve *A* is released, the retaining dogs *B* are forced inward by the action of spring *C* and engage an annular groove extending around the collet. These dogs or pins *B* prevent the

collet from dropping out of the chuck. Both tapping and drill collets are shown in the illustration. The tapping collet is provided with an adjustable friction for safeguarding the tap against breakage. The conical frictions *H*, which are of fiber, are located between the body *F* of the collet and the sleeve *G*. The tension of the friction is adjusted by the nut *J*, so that the tap will slip if the torsional strain becomes excessive. The collet is made 0.015 inch smaller than the bore of the chuck to provide a slight floating movement. This chuck is manufactured by E. Horton & Son Co., Windsor Locks, Conn.

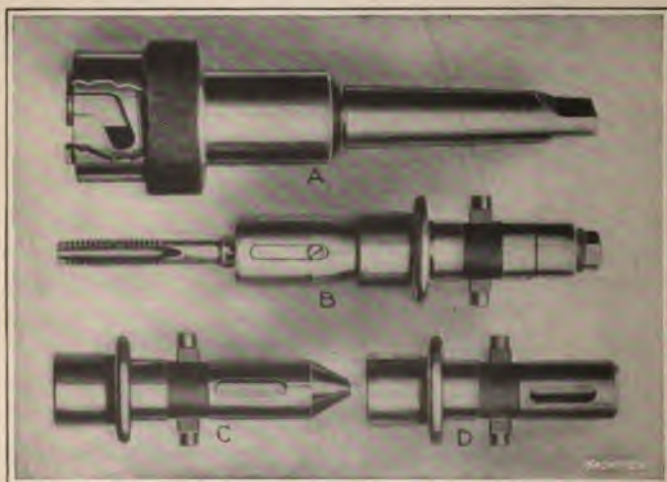

Fig. 9. "Wizard" Quick-change Chuck and Collets

Another chuck designed for the rapid insertion or removal of tools is shown at *A* in Fig. 9. Some of the collets used in conjunction with this chuck (manufactured by the McCrosky Reamer Co.) are also shown in the illustration. These collets each have two driving lugs projecting from the side that engage slots in the chuck when in use. The chuck consists principally of a driving body, which is equipped with a Morse taper shank to fit the drill-press spindle, and a slotted collar for holding the collet up into the driving body. This collar is held in position by a headless screw, and is provided with a coiled spring which

keeps it normally in the closed position. A thin sleeve is screwed over the slotted portion of the collar merely to cover up the slots and screw. A slight resistance to the motion of the collar, such as would be caused by grasping it with one hand while the spindle is in motion, opens the slot in the chuck so that a collet may either be inserted or allowed to fall out of the chuck. The spring previously referred to then throws the collar back to the closed position, which serves to lock the collet into place. A friction drive tapping collet for use with this chuck is shown at *B*. The particular collet illustrated is intended for the Beaman & Smith style of tap shank. The collet illustrated at *C* is provided with a Morse taper hole and is intended for holding a tap drill or other tool having a tapered shank. The collet is one solid piece of steel, and it will be noted that the upper end has a conical point. The upper end of the slot in the chuck *A* is angular, and this tends to force the collet upward so that it is accurately centered by the conical end which engages a seat in the chuck. This collet is so made that it bears in the chuck only on the taper end and on that part of the collet between the driving lugs and flange. This flange or collar is convenient when pushing a collet up into the chuck or when catching it when released. The collet shown at *C* is held rigidly in the chuck, whereas the form illustrated at *D* has a floating movement.

The type of quick-change tool-holder illustrated at *A* and *B*, Fig. 10, which is the product of the Errington Mechanical Laboratory, New York City, is intended for use with a friction "slip-chuck" *C*, or an automatic reverse chuck in case the drilling machine is not equipped with a tapping attachment. The two driving pins seen on the lower face of the chuck have retaining collars or flanges at the end and engage holes in the flange of drill-holder *A*, or holes in the body of the tap-holder *B* when either the drill- or tap-holder is in use. A tool-holder can be inserted in the chuck by simply pushing it up into place, or it can be removed from the chuck while the spindle is revolving by depressing a releasing spring. The automatic-reverse chuck referred to is arranged to reverse the motion for backing out the

tap. This chuck is arranged to receive the quick-change tool-holders, and may be locked for drilling by pulling out a slide. When tapping, this slide is pushed in, which enables the motion of the tap to be reversed, the same as when using the regular automatic-reverse tapping chuck. The chuck with the pin drive is adapted especially for the heavier classes of tools. For comparatively light weight tools that can safely be dropped out of the socket, a ball-drive chuck is recommended. The shank of this chuck is bored out to receive the tool-holding socket, which

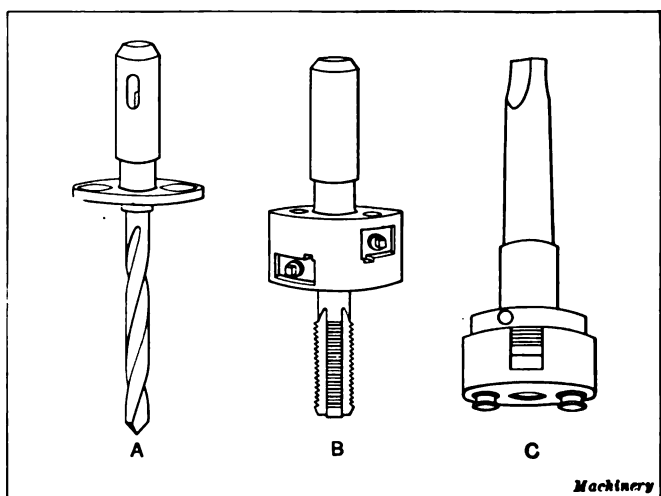

Fig. 10. Errington Drill-holder, Tap-holder, and Quick-change Chuck of Frictional Pin-drive Type

has concave crosswise grooves near the upper end which are engaged by the two driving balls. When a sliding sleeve is raised the balls fly outward, thus releasing the tool socket. As soon as another socket is inserted in the chuck, the sleeve is lowered and an inner beveled surface on it forces the balls in to the driving position. Tools may be inserted or removed while the spindle is in motion.

Sliding-collar Type of Quick-action Chuck. — The quick-action chuck shown in section in Fig. 11 is operated by raising or lowering a sliding collar, for inserting or removing a tool-

holding collet. The taper shank *A* enters the machine spindle, the collet *B* holds the tap or other tool, the two keys or "pawls" *C* drive the collet by engaging the slots shown, and the sliding collar *D* either holds the pawls *C* in the driving position or allows them to move outward in a radial direction for releasing the collet. The sectional view shows the driving pawls in the out-

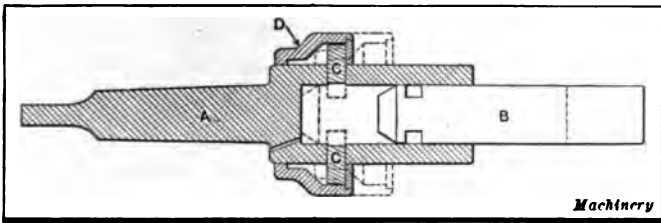

Fig. 11. Sectional View of Quick-action Chuck with Operating Collar in Position for Releasing or Inserting Collet

ward position to permit inserting or releasing a collet. When the sliding collar is pushed downward, the pawls come into contact with a conical surface and are forced inward to the driving position, as indicated by the dotted lines. This chuck is manufactured by the Quick-action Chuck Co., Grand Rapids, Mich. The collet with its tap, drill, or other tool may be inserted or

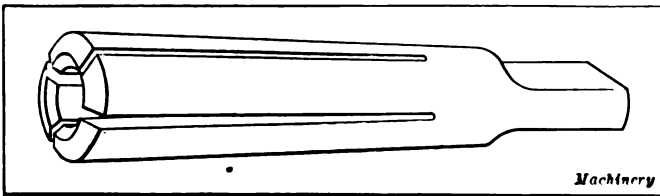

Fig. 12. Scully-Jones Tap Chuck

removed from the chuck while the machine spindle continues to revolve.

Socket or Collet Type of Chuck. — The tap-driving chuck shown in Fig. 12 is formed of one piece of steel and is without retaining screws, pins, or other separate parts. This chuck is practically a collet or socket having four slots extending in a lengthwise direction to allow enough contraction of the chuck

for firmly gripping the tap shank. The chuck is made to a standard Morse taper and is inserted directly in the machine spindle. Any pressure in an axial direction naturally causes the flexible body of the chuck to grip the tap shank, the grip increasing as the pressure increases. This chuck (which is made by Scully-Jones & Co., 647 Railway Exchange Bldg., Chicago, Ill.) holds taps in alignment with the spindle even though the shank may vary somewhat in size.

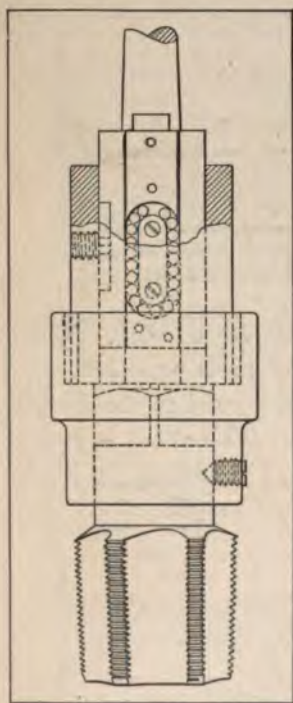

Fig. 13. Cincinnati-Bickford Friction-reducing Tap Chuck

Friction-reducing Tapping Chuck.

— Poorly tapped holes may be due to the frictional resistance of the tap-driving spindle to motion in a lengthwise direction. The feather or key that drives the spindle of a drilling machine is subjected to considerable pressure, particularly when tapping rather large holes, and the natural tendency of the tap to advance or screw itself into the drilled hole is partially or entirely resisted in some cases. The result is that the tap cuts a poor thread or fails to start and simply enlarges the end of the hole like a reamer. The tap chuck shown in Fig. 13 (made by the Cincinnati-Bickford Tool Co., Cincinnati, Ohio) is so constructed that the tap can advance independently of the driving spindle, and the frictional resistance is reduced to a minimum by means of ball bearings. The central part of the chuck, which engages the machine spindle, connects with an outer sleeve by means of two rectangular shaped keys which are surrounded by ball bearings, as the illustration shows. The lower end of this sliding sleeve is attached to the tap-holder proper. In tapping a hole, the operator exerts a slight pressure on the tap when it first comes into contact with the work. The tap

then advances in accordance with the pitch of the thread, the frictional resistance to this movement being reduced to a minimum by the ball-bearing driving keys referred to. This friction-reducing feature tends to prevent any reaming action or the stripping of the thread, especially when driving comparatively large taps, which without the ball-bearing feature would have to advance against considerable frictional resistance.

Tap-holder of Oldham Coupling Type.— The tap-holder illustrated in Fig. 14 applied to a vertical boring mill is similar in

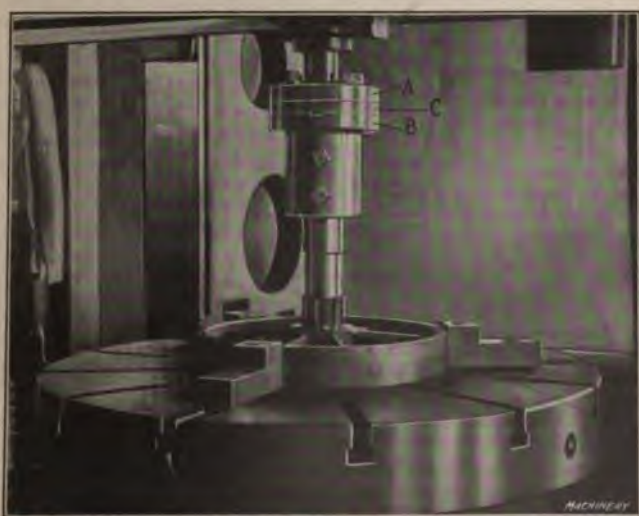

Fig. 14. Tap-holder designed on Principle of Oldham Coupling

principle to the well-known Oldham coupling. The particular operation shown is that of tapping lathe faceplates. The holder is formed of three sections *A*, *B*, and *C*. Part *A* is attached to the tool-slide of the boring mill, part *B* holds the tap, and the central section *C* has a tongue on the upper face engaging a groove in *A*, and a tongue on the lower face engaging a groove in *B*. These tongues are at right angles, so that the tap-holder is free to move laterally in case the tap is not in alignment with the hole. The three sections of the tap-holder are held together by four large cap-screws that are threaded into the lower half of

the coupling but pass through enlarged holes in the central section and the upper part that is attached to the tool-slide.

Attachments for Reversing Tap Rotation.—When drilling machines are used for tap driving, the reverse movement for backing non-collapsing taps out of holes after the thread is cut to the required depth may be obtained either by reversing the spindle of the machine or by using a special chuck or attachment designed to reverse the motion of the tap. Many drilling machines are not equipped

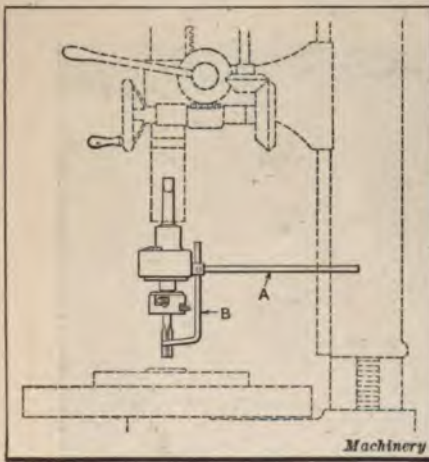

Fig. 15. Diagram illustrating General Arrangement of Errington Automatic-reverse Tapping Chuck and Application to Drilling Machine

with a mechanism for reversing the rotation of the spindle and a special attachment is then required. An automatic-reverse tapping chuck or attachment, which is manufactured by the Errington Mechanical Laboratory, New York City, is shown applied to a drilling machine in Fig. 15. This chuck has a taper shank which is inserted in the spindle of the machine. The body of the chuck and the gage *B*, which may be used to control the depth to which holes are tapped, are both prevented from rotating with the machine spindle by a rod *A* which, in the case of a drill press, rests against the left-hand side of the machine column and slides up or down the column as the spindle is raised or lowered. When tapping a hole, the regular feed-lever or handwheel of the machine is used to lower the spindle as the tap passes down into the hole; when the lower end of stop-rod *B* comes into contact with the face of the work, the direct forward motion drive is released and the tap stops revolving. The machine spindle is then raised; this movement, by the engagement

chuck and the gage

of gearing within the chuck body, causes the tap to back out of the hole rapidly. Raising or lowering the machine table or work would have the same effect.

The tap-holder used in conjunction with this automatic reversing chuck may or may not have an adjustable friction drive for safeguarding taps against breakage. For tapping holes in cast iron, brass, etc., or where blind holes are deep enough to prevent the tap from striking the bottom, the frictional form of holder may not be required.

The latter is intended especially for tapping in steel or for bottom tapping. This automatic-reverse tapping chuck is sometimes used with advantage for tapping two or more holes at the same time. The exact method of arranging these chucks for multiple tapping operations depends to some extent upon the nature of the work.

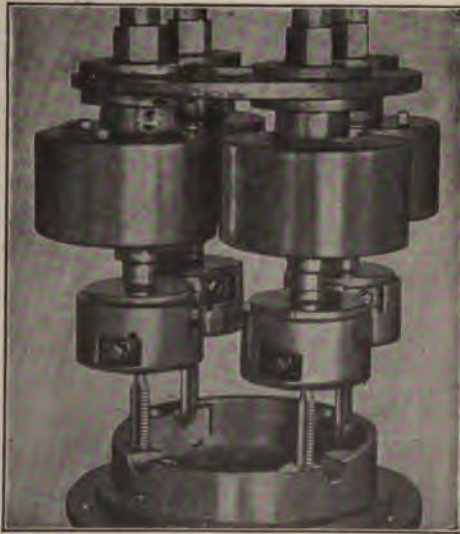

Fig. 16. Errington Multiple Tapper

Fig. 16 illustrates how four holes were tapped

in malleable-iron gear-cases simultaneously. The chucks are prevented from revolving and are held in the right position by a plate or fixture at the top, which is special for this particular job.

Tapping Attachment having an Oscillating Movement.— When tapping holes in steel and other hard materials with hand-operated taps, it is common practice to alternately advance the tool and then turn it back through part of a revolution in order to assist in breaking up and clearing the chips to prevent breaking the tap. This practice is duplicated automatically in a tapping attachment (see Fig. 17) which is

manufactured by the Wahlstrom Tool Co., Brooklyn, N. Y. For tapping cast iron and similar materials, this oscillating movement is not required, and for work of this kind, provision is made for disengaging the oscillating drive and engaging a continuous forward drive. This change is made by turning the knob seen in front of the attachment. When

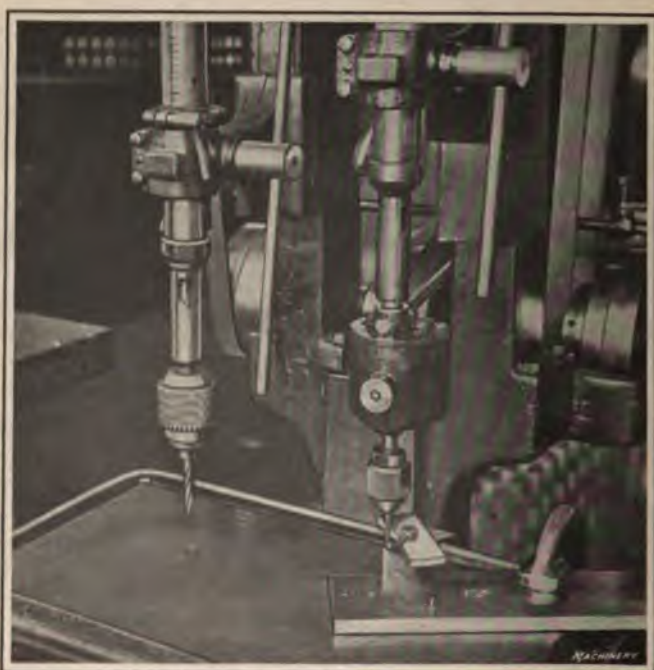

Fig. 17. Wahlstrom Tapping Attachment designed to give Tap an Oscillating Movement when tapping Steel

either the oscillating or continuous forward drive is used, the tap is backed out by raising the lever that controls the hand feed of the drilling machine spindle. This results in positively clutching a continuous drive that backs out the tap at high speed. A special chuck furnished with the attachment grips the round shank of the tap as well as the squared end, so that the shank is supported right down to the end of the chuck.

Variable-speed and Reversing Attachment.—The attachment illustrated in Figs. 18 and 19 has three forward speeds and a reverse motion, and it is adapted either for tapping operations or for speeding up small drills. The speed changes are controlled by turning the knurled knob at the front, which is provided with a suitable handle or lever that also serves to reverse the motion. Fig. 19 illustrates the geared speed-changing



Fig. 18. "Wizard" Variable-speed and Reversing Attachment

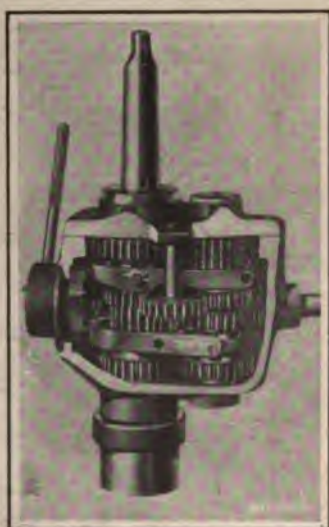

Fig. 19. Interior Mechanism of "Wizard" Variable-speed and Reversing Attachment

mechanism. These changes are effected by means of two positive clutches, which are shifted by turning the knurled knob referred to. When using the slow or direct speed for tapping or driving large drills, the gears run idle, the direct speed being the same as the spindle speed. When this attachment is applied to a drill press, a bar extends from the attachment to the column of the machine to prevent the attachment from rotating with the spindle. The variable-speed feature makes it possible to drive a small drill at high speed, a large drill at the low or

direct speed, whereas the reversal of motion may be used for backing a tap out of the hole after the tapping operation. The tapping may also be done at a slow speed and the tap backed out at a higher speed. This attachment is made by the McCrosky Reamer Co.

CHAPTER VIII

TAPPING MACHINES

THE machines used principally for tap driving include drilling machines, turret lathes, automatic screw machines, and special tapping machines. The type of machine or attachment used for tapping may depend altogether upon the relation of the tapping operation to other operations. The number of holes to be tapped and the advantages or disadvantages of doing both drilling and tapping on one machine should also be considered. Regular drilling machines are extensively used for tapping, because the latter operation naturally follows the drilling of the hole. In many cases, the work is so large and cumbersome that there is a decided advantage in tapping it on the same machine used for drilling. The drill press is also used for tapping a great many small parts, but when large numbers of pieces are required, special tapping machines are frequently used. Tapping operations in turret lathes, automatic screw machines, horizontal and vertical boring mills naturally follow the turning, drilling or boring operations in these machines. A special tapping operation is thus avoided and greater accuracy is secured between the tapped hole and other machined surfaces.

Tapping Mechanism of Drilling Machines.—The tapping mechanism of a drilling machine for use with non-collapsing taps, may be arranged not only to reverse the rotation of a tap for backing it out of the hole, but also to safeguard the tool against excessive torsional stresses by means of an adjustable friction located somewhere between the tap and the source of power, which slips in case an unusual amount of resistance is encountered. A frictional chuck may be used for this purpose, or an adjustable friction may be introduced somewhere in the spindle driving mechanism of the machine. A tap reversing mechanism of the kind that is incorporated in the design of the

machine instead of being in the form of an auxiliary attachment is shown in Fig. 1. This tapping attachment (which is applied to some of the vertical drilling machines made by the Cincinnati-Bickford Tool Co.), when used in conjunction with the friction back-gear, provides for drilling at a fast speed, tapping at a reduced speed, and then backing out the tap at a relatively high speed. Motion is transmitted through the lower bevel gear shown, when tapping, and through an intermediate spur gear

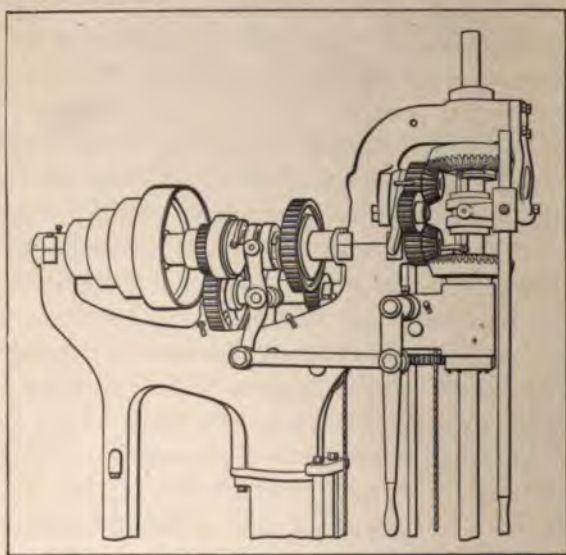

Fig. 1. Tapping Attachment of Upright Drilling Machine

and the upper bevel gear for backing out the tap. The intermediate spur gear is mounted on a sector, so that it can be disengaged when not required for tapping. The forward and reverse motions are controlled by the lever shown, which operates a friction clutch connecting with the bevel gears previously referred to. The method of operating this attachment is to start the spindle backward at the same speed as that for tapping until the tap frees itself, and then the speed is greatly accelerated by a pull on the friction back-gear lever. The illustration shows the attachment with the gear guards removed. While tapping attachments on various makes of drilling ma-

chines differ somewhat as to their general arrangement, these variations usually pertain to details of construction, and as they all operate on the same general principle, other designs for upright drilling machines will not be described.

On radial drilling machines the mechanism used for tapping, commonly known as the "tapping attachment," is incorporated in the design of the drill spindle headstock. This mechanism, like that applied to an upright drilling machine, is simply a combination of gearing through which motion is transmitted for reversing the rotation of the tap. The tapping attachment of the Fosdick radial drilling machine (Fosdick Machine Tool Co.,

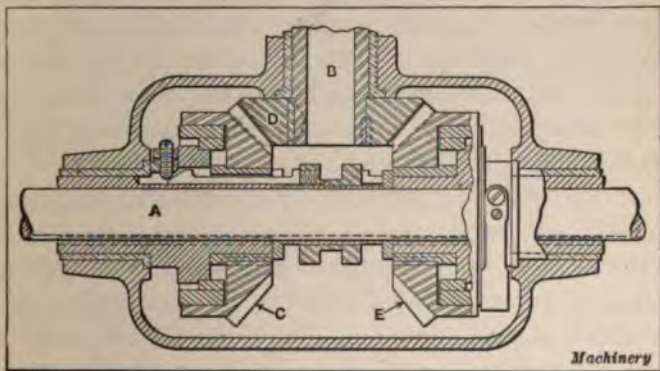

Fig. 2. Mechanism of Radial Drilling Machine for Reversing Motion when tapping

Cincinnati, Ohio) is shown in detail in Fig. 2 as an example of this class of mechanism. Forward and reverse motions are obtained through the combination of three bevel gears shown. This reverse mechanism is mounted on the horizontal driving shaft *A*, which extends along the radial arm. The direction in which the driven shaft *B* revolves depends upon whether motion is transmitted through gears *C* and *D* or *E* and *D*. Either of the two bevel gears *C* or *E* is engaged with the driving shaft by means of expanding ring clutches controlled by a lever or handle located at the right of the lower end of the drill spindle. Motion is transmitted to the drill spindle through back-gears which give three forward and three reverse speeds, with ratios of 3 to 1 and

9 to 1. This back-gearing is controlled by a lever located at the left of the spindle. With this arrangement, taps may be backed out at the same speed as is used for tapping, or at three times or nine times the tapping speed, without changing the regular speed-changing mechanism of the machine.

Special Tapping Machines. — Tapping machines may be intended either for general tapping operations or for use on one class of work, like the tapping of nuts. The designs vary considerably, including vertical and horizontal designs in single- and multiple-spindle types. The spindles may be adjusted on some machines for varying the center-to-center distance, or they may be fixed in the case of machines used exclusively for tapping duplicate parts. Tapping machines also vary in regard to the mechanism for obtaining the forward and reverse motions of the tap-spindle and the method of controlling these motions. A common arrangement for obtaining the two motions is by means of a clutch which is interposed between two pulleys revolving in opposite directions and is alternately engaged with these pulleys. The clutch may be controlled by (1) a hand-lever connecting with the clutch; (2) a foot-lever connecting with the clutch; (3) pushing the work and its fixture forward until contact is made with a stop-rod or lever which shifts the clutch for backing out the tap; (4) pushing the work against the tap while tapping and by pulling in the opposite direction for backing out the tap, the clutch being shifted by the direct thrust from the part being tapped and the resulting longitudinal motion of the tap-spindle. The latter method is applied only to machines used for the lighter classes of work. The characteristic features of well-designed tapping machines are convenience of control and, for small tapping operations, a sensitive drive that will transmit enough power for operating the tap under normal conditions, but not enough to break it in case the resistance to rotation becomes excessive. Several different makes of tapping machines will be described to illustrate variations in design.

Tapping Machines of Horizontal-spindle Type. — A simple form of tapping machine, made by the Garvin Machine Co., New York City, is shown in Fig. 3. This machine has two belt

pulleys driven by open and cross belts, so that they revolve in opposite directions. A clutch is located between the pulleys for controlling the forward and reverse motions. The parts to be tapped are supported by a pad *A* and are held, preferably, in a socket type of fixture designed to prevent the work from revolving with the tap and to permit rapid insertion and removal of the work. The part to be tapped is moved up into contact with the tap by hand-lever *B* connected to the tailstock spindle.

The depth to which the tap enters the hole is controlled by an adjustable stop *C*. When this stop engages the tailstock, thus arresting the forward movement of the tailstock spindle, the tap immediately draws the tap-spindle forward and disengages the clutch. When the feed-lever is moved in the opposite direction, the tap-spindle is shifted over still farther, thus engaging the clutch with the reverse pulley, which is narrower than the driving

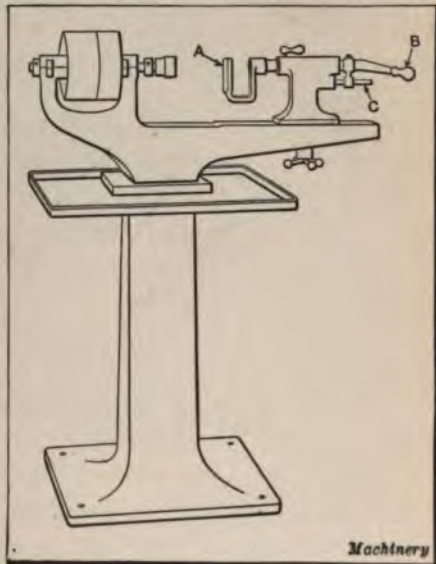

Fig. 3. Garvin Horizontal Tapping Machine

or forward-motion pulley and is located nearer the chuck. This particular machine (which is the No. 2 size) has a capacity for taps varying from $\frac{3}{16}$ up to $\frac{1}{2}$ inch in diameter.

Tapping Machines with Friction-wheel Drive. — Another design of horizontal, single-spindle tapping machine is shown in Fig. 4. This machine (manufactured by the Rickert-Shafer Co., Erie, Pa.) derives its forward and reverse motion from a combination of three friction wheels, consisting of two drivers and one driven wheel which is alternately engaged with the drivers. The driven wheel *A* is made of aluminum and is located between the

driving wheels *B* and *C*, which have friction board driving surfaces. When the part to be tapped is pushed against the tap, the driven wheel is held against the rear driving wheel *C*, which is larger than *B* and revolves at a slower speed. As soon as the hole has been tapped to the required depth, a backward pull of the spindle forces the driven wheel *A* into contact with driving wheel *B*,

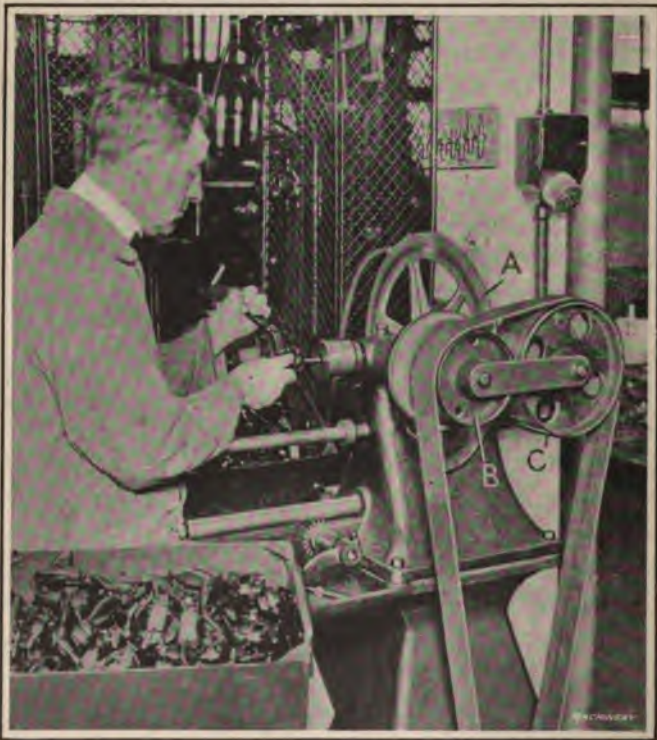

Fig. 4. Rickert-Shafer Horizontal Tapping Machine

thus reversing the direction of rotation and backing out the tap. This machine is driven by a single belt, which passes over the forward and reverse motion driving pulleys, as the illustration shows. These two wheels rotate in the same direction, but the driven wheel is reversed, because it engages pulley *B* on the rear side and pulley *C* on the front side. A work-

holding fixture is not used for the particular tapping operations illustrated, because the tap first passes through a clearance hole which holds it in alignment, so that it is not necessary to provide means for holding the work, which is simply applied directly to the tap.

The horizontal tapping machine illustrated in Fig. 5 (built by the Meriden Machine Tool Co., Meriden, Conn.) operates on

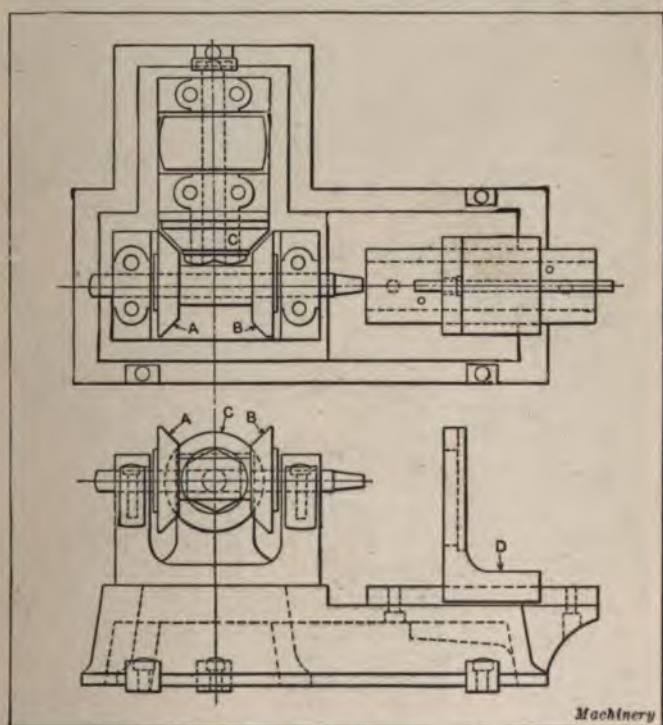

Fig. 5. Meriden Horizontal Tapping Machine

the same general principle as the one just described, but differs in regard to the arrangement of the driving mechanism. The tapping spindle carries two bevel or conical faced wheels *A* and *B*, which are alternately engaged by a third conical faced wheel *C* mounted on the belt-driven driving shaft. The tap-carrying spindle has a free longitudinal movement, and when a piece of work is forced against the tap, the forward cone *B*

is held in contact with the driving cone, thus causing the tap to revolve. When the tap has entered to the required depth and the work is pulled backward, the rear driven cone *A* is brought into contact with the driving cone *C*, thus reversing

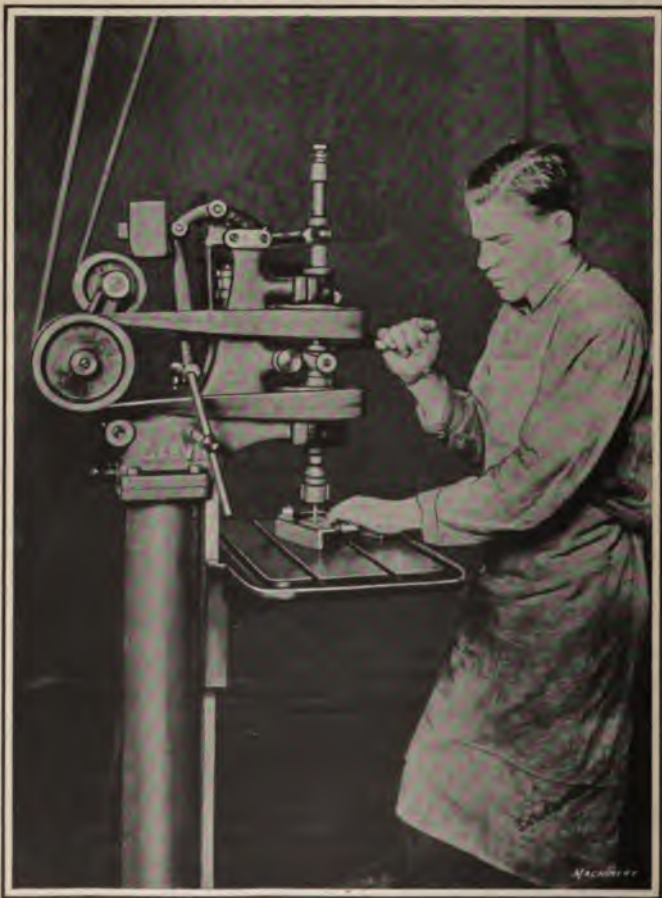

Fig. 6. Garvin Vertical-spindle Tapping Machine

the rotation of the tap. The two driven cones are made of cast iron and the central driving cone is of cast iron faced with leather to increase the frictional resistance. The machine has a slide *D*, which is mounted on V-shaped ways, and is intended

to hold whatever form of fixture may be needed. The slide has an adjustable stop-rod which limits the travel or movement of the work toward the tap. This machine is designed for tapping holes $\frac{1}{4}$ inch in diameter or less. The horizontal tapping machines of the type previously described are adapted especially for small parts which are easily handled.

Vertical-spindle Tapping Machines. — For many classes of work a machine with a vertical spindle is preferable to the horizontal type. A Garvin tapping machine of the vertical type is shown in Fig. 6. The spindle carries two belt pulleys which are driven in opposite directions by one continuous belt. A friction clutch between these two pulleys is brought into engagement with one pulley for starting the tap, by means of the operating hand-lever or by a foot-pedal on some machines. The connection between this lever and the friction clutch is through a mechanism which provides an adjustment for varying the tension in order to safeguard taps against breakage. After the tap is started the machine operates automatically, the tap feeding down to whatever depth the machine is adjusted for and then backing out of the tapped hole. The point at which the reversal of the tap-spindle occurs is controlled by an adjustable screw stop on the upper end of the spindle. This screw stop strikes a tripping lever on top of the machine and shifts the friction clutch located between the two friction pulleys. Fixtures for a machine of this general type should be so designed that the work will not be lifted by the screwing action of the tap.

The vertical-spindle tapping machine illustrated in Fig. 7 has a spherical friction driving disk which is mounted directly on the armature shaft of the motor. The tapping spindle carries two rollers, one being above the center of the driving disk and the other below it. The rotation is reversed by engaging the disk with first one roller and then the other. The motor is pivoted in the frame of the machine at the center of the spherical face of the friction driving disk. By inclining the motor and armature shaft to various angles, changes in the tapping and return speeds may be secured. With this arrangement, if the speed is reduced in one direction it will be increased in the oppo-

site direction. For instance, if the spherical driving disk is so located that the spindle makes 1000 revolutions per minute in the forward and reverse directions and the position or adjustment is then changed to reduce the tapping speed to 500 revolutions per minute, the reverse movement will be increased to 1500 revo-



Fig. 7. Anderson Vertical-spindle Tapping Machine

lutions per minute. The work-table of this machine is moved upward by means of a foot-treadle, as the illustration shows, for bringing the work into contact with the tap. The connection from the floor to the machine is adjustable and is provided with a safety spring so that the leading movement of the tap will not be affected by a sudden application of pressure

on the foot-treadle. The weight of the table is counterbalanced by an adjustable spring which gives a sensitive control of the table movement. The column supporting the table is hollow and may be filled with oil so that, when tapping parts which permit the tap to go through the hole, the tap will dip into the oil. In this way, the tool is automatically lubricated and the chips washed off the end so that they will not injure the thread when the tap backs out of the hole. As this oil chamber gradually fills with chips, the oil level is automatically maintained. A spring at the upper end of the spindle can be adjusted to counterbalance the spindle weight. This machine is capable of tapping holes in cast iron ranging from $\frac{1}{16}$ to $\frac{1}{4}$ inch in diameter and for tapping holes in steel varying from $\frac{1}{16}$ to $\frac{3}{16}$ inch in diameter. The maximum depth to which holes may be tapped is $1\frac{1}{2}$ inch. This tapping machine is built by the Anderson Die Machine Co., Bridgeport, Conn.

Heavy-duty Tapping Machine. — One of the large tapping machines made by Baker Bros., Toledo, Ohio, is illustrated in Fig. 8. This is a 16-inch size and is designed to tap cast-iron pipe fittings varying from $2\frac{1}{2}$ to 16 inches in diameter. This machine is semi-automatic in its action, the reversal of the tap being controlled by means of a pneumatically-operated reversing mechanism. The spindle is fed downward, when tapping, through change-gears which positively control the advance movement of the tap. These gears may be arranged for tapping either 8 or $11\frac{1}{2}$ threads per inch, which cover the pitches of pipe threads for which the machine is intended. One of the interesting features of this machine is the method of driving the spindle. Attached to the top of the spindle there is a cross-arm, the ends of which engage vertical slots in a gear-driven driving head. This head is rotated through a pinion attached to a vertical shaft which connects through bevel gearing with a horizontal shaft that may be driven from the belt pulley shown, either direct or through back-gearing. As the driving head engages the outer ends of the cross-arm on the spindle, there is a relatively low unit pressure on the bearing or driving surfaces; consequently, the frictional resistance to a vertical movement of

the spindle is reduced and the spindle follows the tap more readily than it would if the drive were through a key or spline connecting directly with the spindle. This feature is of especial importance in a machine intended for such heavy work, because considerable power is required for driving the large pipe

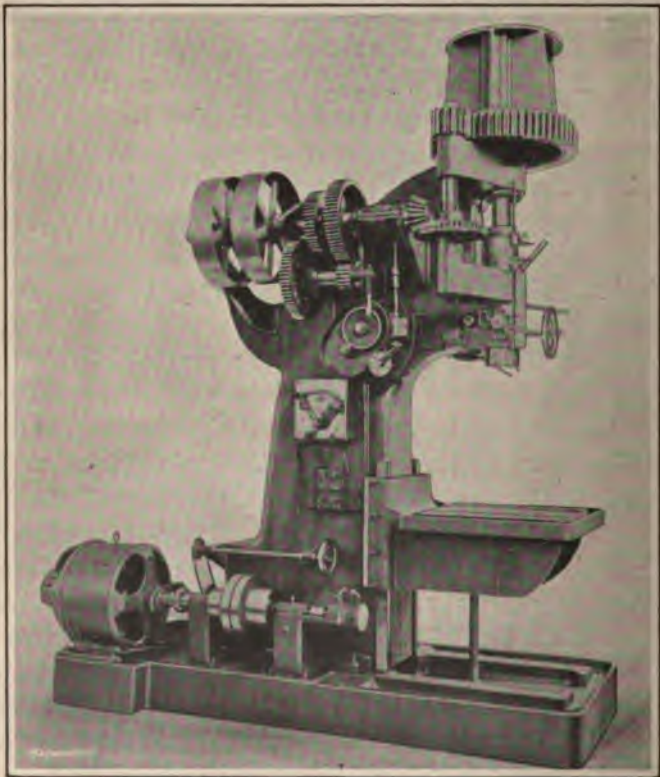

Fig. 8. Baker Sixteen-inch Tapping Machine

taps. When the tap has fed down to the exact depth required, the spindle reverses and stops after the tap has locked out far enough to clear the work. This machine is also adapted to drilling and boring operations.

Radial Type of Tapping Machine. — The tapping machine to be described is adapted especially for tapping parts that are so

large and cumbersome that there is a decided advantage in being able to move the tap-spindle from one hole to another. The tap-spindle (see Fig. 9) is mounted at the end of a radial arm which not only swivels about the vertical column of the machine like the arm of a radial drilling machine, but is pivoted in the center as well. This is a Rickert-Shafer machine and the

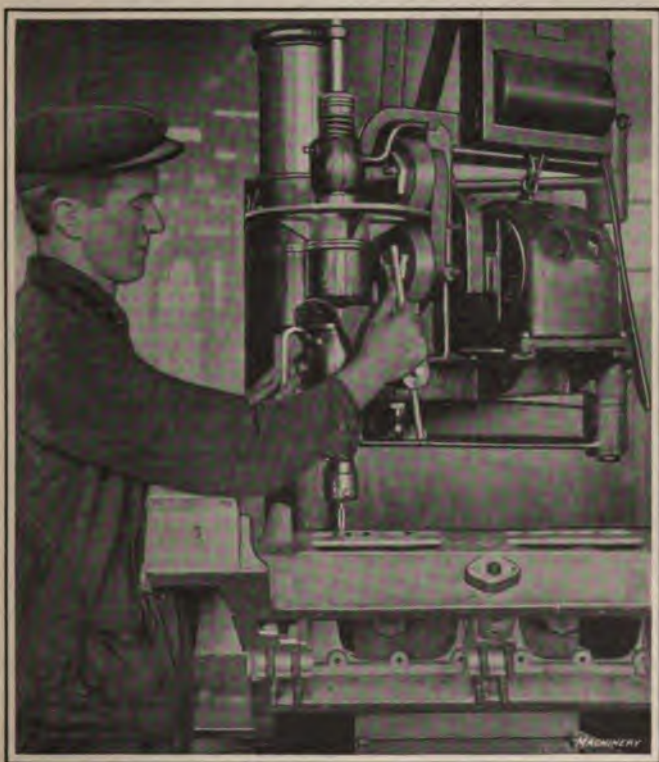

Fig. 9. Rickert-Shafer Tapping Machine of Radial Type

driving mechanism is similar to that applied to the horizontal machine previously described. The tap-spindle carries an aluminum disk which is located between two paper-faced driving frictions. By means of the operating lever, the driven wheel may be engaged with either of the driving friction wheels for obtaining the forward or reverse motions. The aluminum

driven disk has about the same coefficient of friction as cast iron, but its centrifugal force is only about one-third as great. The radial arm is supported by the vertical column. The driving motor is carried by the outer section of the pivoted arm and it drives the friction wheels through gearing. This machine will tap any hole within a radius of 48 inches, and by folding the radial arm the tap may be located within 8 inches of the column.

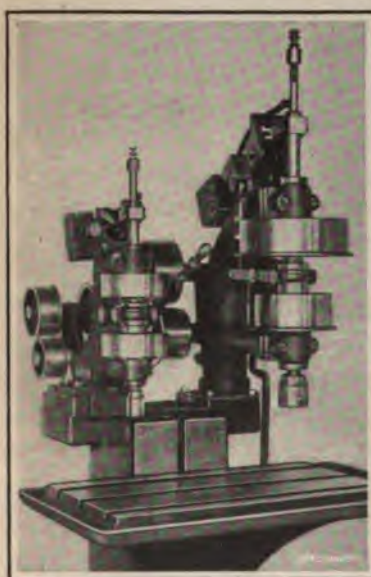

Fig. 10. Garvin Combination Tapping Machine

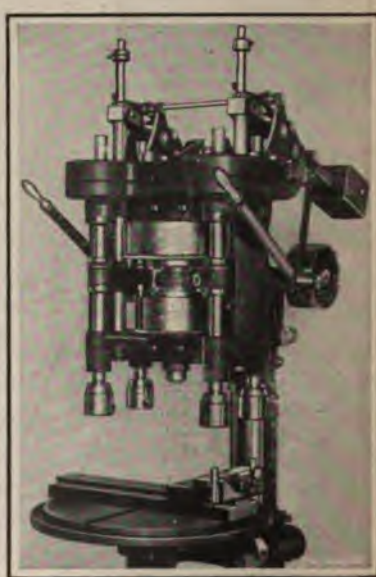

Fig. 11. Garvin Four-spindle Tapping Machine of Special Design

The machine has a capacity for holes in steel varying from $\frac{1}{4}$ to $\frac{1}{2}$ inch and for holes up to $\frac{5}{8}$ inch in diameter in cast iron.

Multiple-spindle Tapping Machines. — Multiple-spindle tapping machines are usually intended for special classes of work, although they are sometimes arranged for general tapping operations. The two-spindle machine illustrated in Fig. 10 is a Garvin combination type. This particular machine is especially applicable when there are two holes to be tapped in a part that differ in size to such an extent that it would not be advisable or

practicable to have both heads of the machine of the same capacity. The machine is equipped with foot-treadles so that the operator's hands are free for manipulating the work.

A four-spindle machine is shown in Fig. 11, the spindles being operated in pairs which are controlled by independent levers. One pair of spindles is intended for rough-tapping, and the other pair for finishing. The parts tapped on this particular machine are made of tool steel and have a comparatively deep hole to be tapped. The work is held by a transverse slide or fixture which, after the rough-tapping, is simply moved over to locate the holes under the finishing taps. The general operation of these two machines is the same as that of the regular Garvin tapping machines previously described.

The special multiple-spindle tapping machine illustrated in Fig. 12 was made by the Moline Tool Co., Moline, Ill., for performing multiple tapping operations on automobile cylinders which are cast *en bloc* (one solid casting) and for a variety of other tapping operations of the same general class. The spindles of this machine are driven from the large crank at the left which connects through a rod with a horizontal rack from which motion is transmitted to the spindles through pinions meshing with the rack. The crank gear, which drives the reciprocating rack, is driven through a train of spur and spiral gears which receive motion from a shifting belt. The upper end of each tap-spindle has a shell lead-screw of the same pitch as the tap. The part to be tapped is held either on a wheeled jig or on the table. The cross-rail is lowered against a positive stop for locating the ends of the taps in position for entering the holes in the work. When the machine is started, the crank gear makes one complete revolution which causes the taps to feed downward a predetermined distance and then withdraw, after which the machine is stopped by a brake. This crank and rack control is employed when it is necessary to tap to an exact depth. A machine of this type may have either fixed or adjustable tap-spindles. This is, of course, a special design and ordinarily would be constructed to meet the particular requirements of a given class of work.

Semi-automatic Multiple-spindle Tapping Machine.— The multiple-spindle tapping machine illustrated in Fig. 13 has spindles located fixed distances apart and is intended for tapping large numbers of duplicate pieces. The machine may be adapted for tapping almost any number of holes grouped within a five-inch circle. The head carrying the tap-spindles is arranged to suit the work. Each spindle is fitted with a special compen-

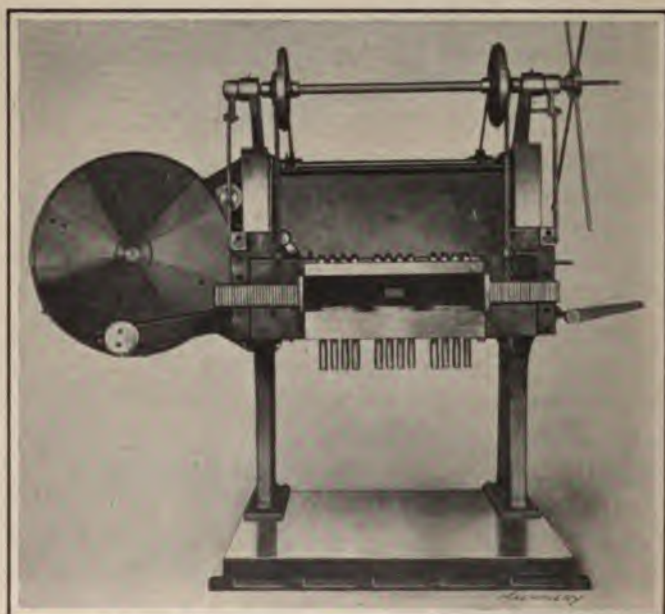

Fig. 12. Moline Multiple-spindle Tapping Machine

sating device which allows every tap in the head to follow its own lead. This feature also permits operating taps of different pitches simultaneously. The main spindle is driven through spiral and spur gearing from a set of three grooved pulleys mounted side by side at the back of the machine near the top. The inner of the three pulleys drives the taps forward and operates the mechanism which raises the machine table at the proper rate for the pitch of tap being used. The outer pulley reverses the taps and also lowers the table at twice the tapping speed.

As soon as the taps clear the work or jig, the machine stops automatically for a long enough period to permit removing the tapped piece and inserting another blank. The driving belt is then shifted mechanically and the cycle of operations repeated. The central pulley is an idler to which the belt is shifted for stopping the machine. This shifting of the belt is controlled by a pilot gear which is driven through change-gears. Adjust-

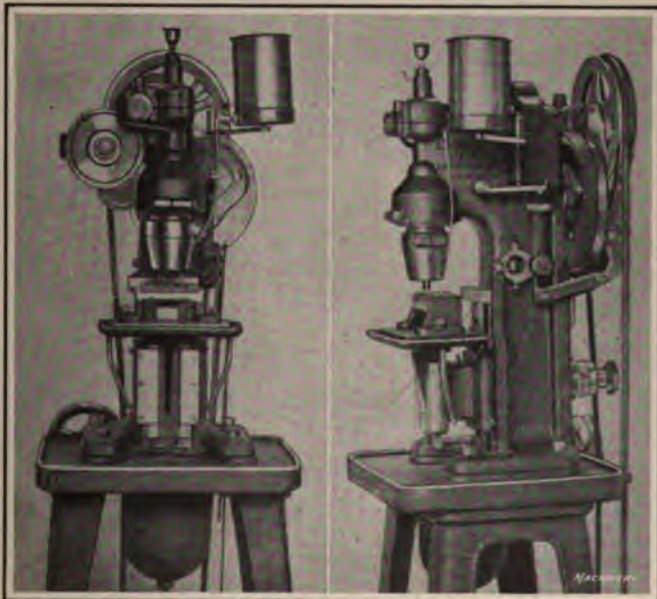

Fig. 13. Langelier Semi-automatic Multiple-spindle Tapping Machine

able dogs on this pilot gear operate the belt-shifting fork. One dog shifts the belt to the idler pulley for stopping the machine and the other one shifts it to the outer pulley for reversing the motion of the taps and the table movement. The position of the dog that shifts the belt to the loose pulley remains the same, but the reverse dog is set with reference to the thickness of the part being tapped. The vertical motion of the table is derived from a face-cam formed on the side of the pilot gear. This machine is made by the Langelier Mfg. Co., Providence, R. I.

Nut-tapping Machines. — Some of the most highly developed and ingenious tapping machines are used for tapping nuts. These machines are made in reversing and non-reversing types and may be hand-operated, semi-automatic, or fully automatic. Reversible machines are used for tapping nuts having closed ends which make it necessary to reverse the tap and back it out. The non-reversible machines may be so arranged that the nuts pass onto a long tap shank from which they are removed periodically, or the tap may be so held and driven that the tapped



Fig. 14. Acme Six-spindle Nut-tapping Machine

nuts pass over it completely without removing it or stopping the machine.

The six-spindle nut-tapping machine illustrated in Fig. 14 is manually operated, a foot-treadle being used to raise the tap-spindle each time a blank is inserted under the tap, which is done by hand as the illustration shows. The spindle and tap feed downward by their own weight and meanwhile the operator is inserting a blank nut beneath the next successive tap, so that the machine operates continuously. The vertical tap-spindles carry gears which mesh with long pinions, allowing the spindles to be raised or lowered without interfering with the drive. A

lever that projects outward in front of each spindle is used for controlling the drive, and enables any one spindle to be stopped independently of the others if necessary. This machine may be used for tapping either square or hexagonal nuts. While nut tappers of this general type have been used extensively, the semi-automatic design to be described represents a more modern type.

Semi-automatic Nut-tapping Machine. — The semi-automatic nut-tapping machine is so arranged that vertical movements of the tap-spindles are controlled mechanically instead of manually. When the six-spindle machine illustrated in Fig. 15 is in operation, the square or hexagonal nuts, as the case may be, are placed by the operator in adjustable chutes. Each of these chutes or magazines holds a sufficient number of nuts to supply the tap which it feeds for some time. The chutes are placed in front of the machine, above the nut storage space provided in the bed, and are at an angle of from 30 to 45 degrees with the axis of the tap-spindle, and a distance to the right depending upon the size of the nut. On the top end of each tap-spindle and revolving with it is mounted a special form of hardened steel worm. This worm performs the work of raising the spindle. When the spindle and tap are in the lower position, caused by the tap feeding through the nut, a finger or key is automatically projected into the space between the worm threads. The finger is stationary in the vertical plane and the worm engaging it travels upward and raises the spindle a distance equal to the length of the worm cylinder. The spindle and tap are then lowered and the tap enters the blank nut, which is in position under and in line with the tap.

An arrangement of adjustable counterweights almost balances the weight of the tap-spindle, so there is no appreciable shock imparted to the tap when entering the nut. The nut is delivered from the base of the chute to the tapping position, by a swinging arm that derives its movement from the mechanically lifted tap-spindle. This swinging arm carries a relief device, so that in the event of any obstruction in the path of the nut the parts delivering the nuts are relieved from undue strain. When the tap shank is filled with nuts, the spindle automatically ceases

to rise, but continues to revolve. This function is controlled by the tapped nuts on the shank of the tap, so that the tap-spindle continues to rise after each nut is tapped until the tap shank is filled. The operator then raises the spindle with the foot-treadle, removes the tap from its socket, empties the nuts from the tap shank, and returns the tap to the socket; the work then contin-

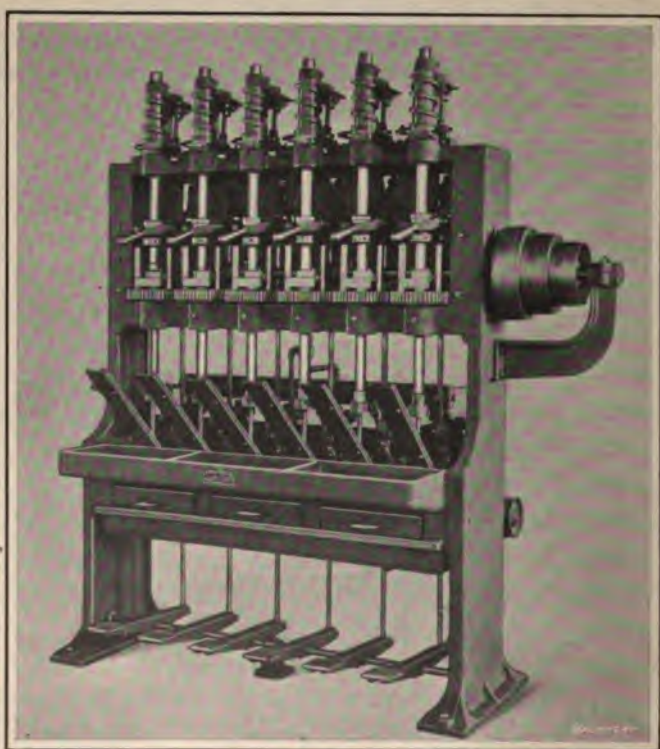

Fig. 15. Acme Semi-automatic Nut-tapping Machine

ues automatically. The sockets or chucks for holding the taps are designed to permit rapid insertion or removal.

The automatic feature of raising the tap-spindle and delivering the blank nut to the tap is an individual one with each spindle, so that when the operator is removing nuts from one tap, the other spindles continue to work automatically. A small latch or lever attached to each spindle enables the operator

to discontinue the automatic lifting function on one or more spindles if desired. The nut-holder plates are fitted with adjustable hardened steel blocks that can be adjusted to suit any size nut within the range of the machine. The front block is attached to the adjustable chute and the chute is fastened to the holder plate. The gear through which each spindle is driven meshes with a long driving pinion and moves vertically over the face of the pinion. This produces an action free from tendency to raise the nut from the holder plate during the tapping operation. Power is transmitted to the machine by means of cone-pulleys, giving a range of speeds necessary for each size nut within the capacity of the machine. A suitable compound is supplied by a rotary pump, each tap having an individual spout and control cock. The machines shown in Figs. 14 and 15 are manufactured by the Acme Machinery Co., Cleveland, Ohio.

Automatic Tapping Machine of Bent-tap Type. — Many attempts have been made to design tapping machines that would operate automatically and continuously. The principal problem has been to separate the tapped nuts from the tap without removing the tap from its holder. One method of securing continuous operation and avoiding the reversal of the tap-spindle is by the use of a tap having a bent or curved shank. This shank is curved to form a right-angle bend of rather large radius and it is held in a groove in the tap-holder. This groove is large enough to allow the tapped nuts to slide over the shank. The right-angled bend of the tap shank causes the tap to revolve with the spindle and the tap is steadied by the nuts which are continually passing over the shank when the machine is in operation. An automatic nut-tapping machine in which the bent tap principle has been utilized successfully is illustrated in Figs. 16 and 17. In Fig. 16 the tap-holder is opened to show how the tapped nuts pass over the curved tap shank before being ejected at the end. The nut blanks are fed automatically from a hopper (see Fig. 17) down through a chute to the tap. The nut blanks are delivered from the hopper to the feed-chute by means of feed vanes and they are carried down by gravity against the plunger or "starter" which starts them onto the tap. There

are four of these feed vanes which are enclosed in a case in the center of the hopper to prevent interference from the mass of blank nuts in the hopper. The vanes are rotated through a ratchet and pawl mechanism. The ratchet is held between friction flanges so that in case there is any wedging in the nut groove and retardation of the feed vanes, the ratchet merely slips and damage to the mechanism is avoided.

The tap-spindle is inclined at an angle as shown in Fig. 16. The starter which transfers the blank nuts from the lower end

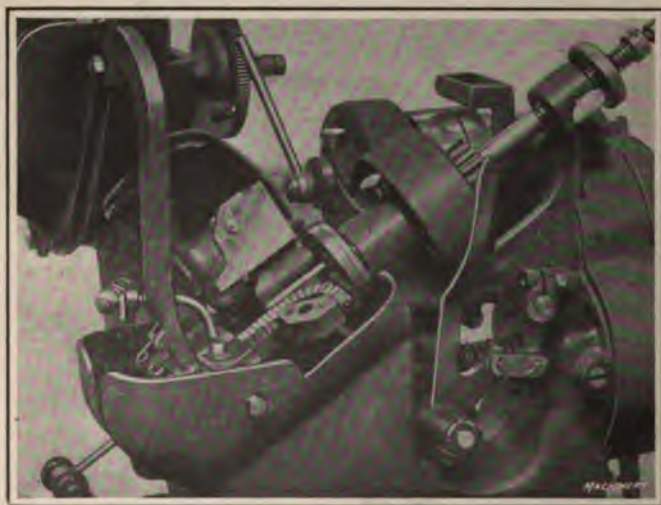

Fig. 16. National Automatic Nut-tapping Machine

of the chute to the tap is also inclined. The nut blanks leave the end of the chute at a corresponding angle so that they are in the proper position for starting on the tap. The tap-spindle has a slight lateral travel or the equivalent of a floating movement. After a blank has been fed part way onto the tap by the starter, the spindle descends during the completion of the tapping operation. With this arrangement the blank is held stationary while being tapped instead of pulling it through a nut-holder or guides. This machine was designed primarily for tapping square nuts, although hexagon nut blanks of good

quality can also be tapped with it. One of these machines may also be arranged for tapping several different sizes, and by making a simple gear change the number of nuts tapped per minute can be regulated to suit the work. For instance, on a $\frac{3}{8}$ -inch machine, forty nuts of "shop" size can be tapped per minute if the stock is free cutting, the holes of the proper size, etc. U. S. standard nuts, which are thicker, require more turns of the tap for each nut, so that the production would be reduced to thirty nuts per minute. A similar reduction would have



Fig. 17. Hopper from which Blank Nuts are fed automatically

to be made if the nut blanks were of tough stock or the holes smaller than they should be. This type of machine is manufactured by the National Machinery Co., Tiffin, Ohio.

Station-type Tapping Machine. — A special design of tapping machine intended for tapping the receivers and bolts of military rifles is shown in Fig. 18. The work-holding fixtures are mounted on the six faces of a central turret, and surrounding this turret are five tapping spindles. This leaves one blank position which is located at the front of the machine for the purpose of removing the finished product and replacing new blanks.

The taps work progressively for tapping the holes to the required depth. The five spindles carry pinions which mesh with a common central driving gear. At the lower end of the central gear shaft there is a combination clutch and bevel gear type of reversing mechanism by means of which the forward and reverse motions for the tapping spindles are obtained. The reversing clutch operates automatically. The rate at which the taps are fed to or withdrawn from the work is governed by independent

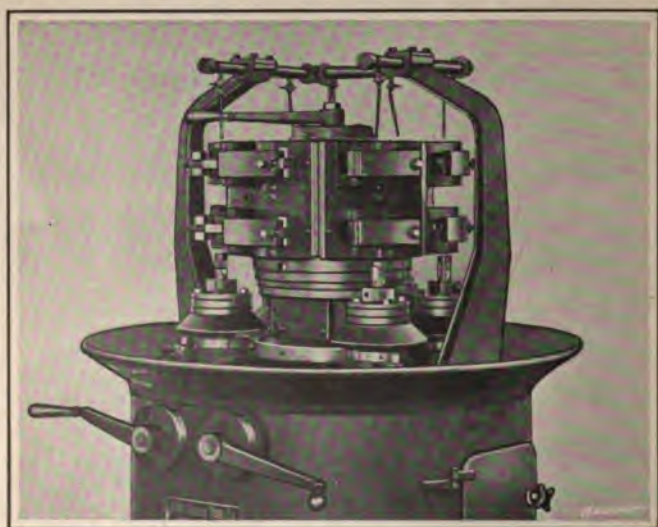

Fig. 18. Baush Station-type Tapping Machine

lead-screws of the proper pitch. The indexing movement of the turret is effected by the hand-lever seen above the turret. When this lever is moved to the right it withdraws a locking bolt and allows the turret to drop onto a ball bearing track over which it is suspended. The same lever is then moved in the opposite direction to advance the work to the next station, after which the locking bolt springs into place. A slight additional movement of the index lever then lifts the turret off the roller bearing track and its upper face comes into contact with the finished face of an aligning block. The fixtures attached to the turret are designed in accordance with the part being tapped. The

usefulness of the machine is not confined to the tapping of rifle parts, as it may be applied to other classes of work. This machine is made by the Baush Machine Tool Co., Springfield, Mass.

Work-holding Fixtures for Tapping.—Parts to be tapped may be held in position during the tapping operation either by their own weight or by some kind of special fixture in the case of comparatively light parts. A simple and effective method of holding pieces on the table of a drilling machine, provided the work is light enough to center itself with the tap, is illustrated by diagram A, Fig. 19. Two parallel strips *a* are bolted to the

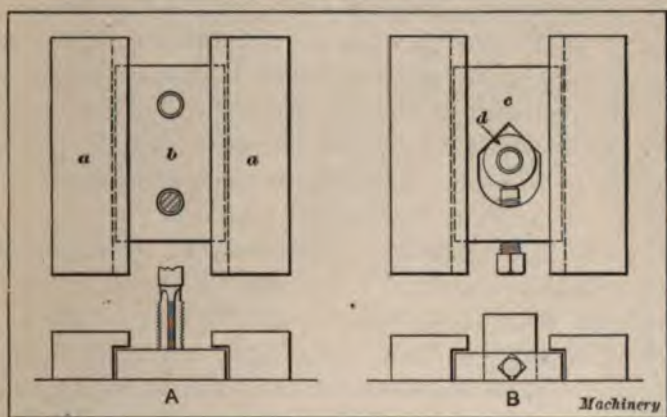

Fig. 19. Simple Methods of holding Work while tapping

table of the machine far enough apart to allow whatever piece *b* is to be tapped to slide freely into position. These parallel strips simply prevent the work from rotating when the tap is entering or backing out of the hole. If the work does not have parallel sides, an auxiliary plate may be used to hold it. This plate may simply have a pocket or depression shaped to receive the work. In any case, the arrangement should be such that the part may be inserted and removed as rapidly as possible. By having the parallel strips under-cut to form a T-slot as shown, the screwing action of the tap cannot lift the work away from the machine table. Parts to be tapped in this way are first drilled and then tapped instead of performing the drilling and tapping operations without rehandling the work, as is frequently

done when tapping pieces that are clamped to the machine table or are too heavy to center themselves when the tap enters the drill hole.

When tapping nuts, small blocks, etc., on a drilling machine, instead of placing one untapped blank at a time between the parallels, there may be an advantage in having a row of parts which is advanced for tapping each successive part, whenever an untapped blank is inserted at the feeding end of the parallels. With this method, the untapped pieces are pushed in between the parallels at one end and the tapped pieces are ejected at the other. These parallels, with whatever modification may be necessary, are often convenient for holding rods, etc., while tapping holes that extend crosswise through the work. The sketch at *B*, Fig. 19, illustrates how an auxiliary plate *c* may be used for holding a cylindrical part *d* when tapping a hole in the end. The work is clamped against the V-shaped side of the plate opening by a set-screw.

The special tapping fixtures sometimes used on tapping machines for holding duplicate parts are, as a general rule, so designed that the work is held by some form of pocket or arrangement of stops so that clamping is unnecessary. It is also important to so construct the fixture that the tap cannot lift or draw the work out of place during the tapping operation. The tapping fixture illustrated in Fig. 20 embodies these fundamental points, and the general features of this construction are found in many fixtures of the class used for holding small duplicate parts which are tapped in large quantities. The small sheet metal part held in this particular fixture is shown at *A*. The fixture is provided with slots or pockets for holding the work in position as indicated at *B*. The flange-shaped member *C*, in which the work-holding slots are formed, is mounted on the end of a spindle *D* which is free to slide through the bearing *E* attached to the stand *F*. The shape of the slot for receiving the untapped blanks may be varied according to the shape of the work. In this particular instance, plain radial slots serve the purpose. Bearing *E* may be adjusted vertically in stand *F* to align the tap clearance hole of whatever fixture *C*

may be carried by spindle *D* with the tap of the machine. Fastened to spindle *D* there is an index plate *G* provided with holes spaced to correspond with the work-holding slots in part *C*. These index holes are engaged by a pin *H*, which is fixed to the rear side of bearing *E*. When this fixture is in use, the operator with his left hand inserts an untapped blank as each slot arrives at position *J*; the spindle *D* is pushed forward or withdrawn by the right hand, which grasps knob *K*. When applied to one design of tapping machine, the spindle of the fixture is pushed forward until the hole has been tapped and engagement with lever

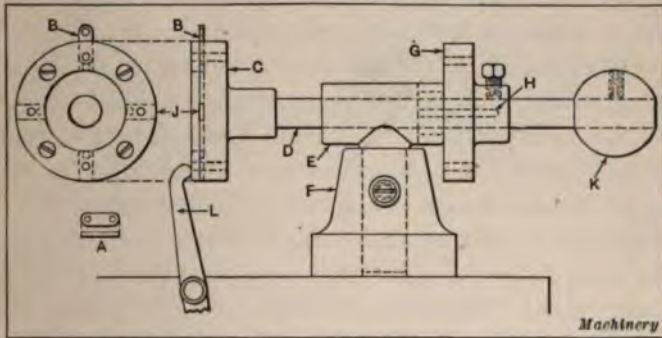

Fig. 20. Design of Fixture which, with Modification, has been extensively used for Holding Small Parts while tapping

L causes a reversal of motion; spindle *D* is then forced backward by the action of the tap, and as soon as the tap is withdrawn from part *C*, the latter is turned one-quarter revolution as determined by the engagement of pin *H* with a hole in plate *G*. This indexing movement locates the blank, previously inserted at *J*, in the tapping position. By means of a foot-treadle, the tap is again reversed so that it rotates in a forward direction and then the cycle of movements is repeated. As the tapped parts are indexed around they fall out of the fixture by gravity. The index pin *H* is of such a length that it will not release plate *G* until the tap clears the end of the fixture. A great many tapping fixtures for small work have been designed on this general principle, the details being modified more or less according to the requirements in each case.

CHAPTER IX

STANDARD AND SPECIAL THREADING MACHINES

WHEN thread cutting is a separate operation or the only one required and particularly where there are large numbers of duplicate parts to be threaded, machines designed especially for this work are often used. These "threading machines" are ordinarily equipped with dies, and they may be designed for hand manipulation or for either semi-automatic or automatic operation. Machines of this general type are used for cutting threads on bolts and studs of various kinds and on the ends of rods, etc. Some of these machines have a single spindle, whereas others are equipped with two or more spindles. Most threading machines are of horizontal design, although some of the more special types have the spindles in a vertical position.

Single-spindle Threading Machine or Bolt Cutter.— The term "bolt cutter" is very generally applied to threading machines of the type used for cutting threads on bolts, studs, rods, and similar parts. A machine of this class having a single spindle is illustrated in Fig. 1. The die-head *A* which cuts the thread is carried by the main spindle, which is driven from belt pulley *K*. In this particular case, the drive to the spindle is through reduction gearing. Many of the smaller sizes of threading machines or bolt cutters have the belt pulley mounted directly on the spindle. The bolt or other part to be threaded is held in a vise or holder *B*, which is mounted upon a carriage. This carriage is traversed along ways and in a direction parallel to the spindle by handwheel *C*. This traversing movement is utilized to enter the bolt or other part into the die and also for withdrawing the work after the thread is cut and the die is opened. As soon as the die has started, the part being threaded and the carriage are traversed automatically by the action of the

die itself, on this particular machine. In some cases, a lead-screw is provided as will be explained later.

The die-head is so arranged that the die chasers are opened or moved outward in a radial direction for clearing the work when a thread has been cut to the required length. This opening of the die is controlled automatically; it is also closed to the working position when the carriage is returned to the starting point for removing the threaded part and inserting a new blank. This automatic opening and closing of the die is a feature common to bolt cutters of different designs. The action of the die is con-

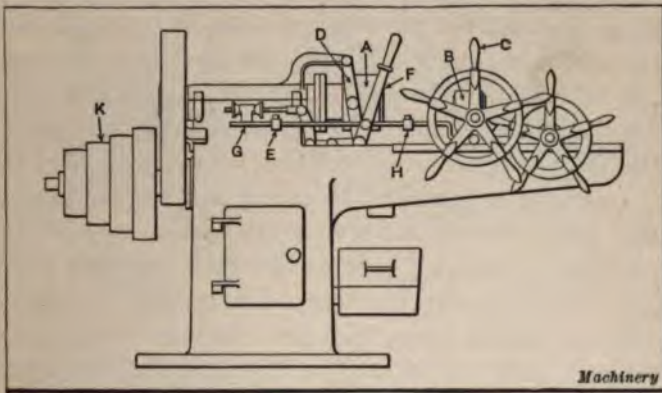

Fig. 1. Single-spindle Threading Machine or Bolt Cutter

trolled by a yoke *D* which is connected with rod *G*. The latter carries two stop-collars *E* and *H* which are adjusted along the rod in accordance with the length of thread to be cut. Thus, when the carriage comes into contact with stop-collar *E* at the completion of the threading operation, the die is opened, and when it engages stop-collar *H* at the end of the return movement the die is again closed. The lever *F* may be used for opening or closing the die by hand.

The spindle of the machine is hollow so that a screw thread of practically any length may be cut. If this length exceeds the traversing movement of the carriage, the latter is shifted backward along the rod being threaded, after it has traversed the full amount. Machines designed especially for cutting threads

on boiler staybolts are practically the same as an ordinary bolt cutter, excepting that the bed is of extra length to permit threading staybolts by taking one continuous cut. Most of the bolts or screws handled by these threading machines are cut with a single passage of the die. If an exceptionally smooth finish is desired, however, or when cutting a thread requiring the removal of considerable metal, a die-head is frequently used that will permit taking roughing and finishing cuts.

While threading machines in general are designed for cutting external threads, they are sometimes used for tapping operations, especially when the number of parts to be tapped is not great enough to warrant the purchase of a special tapping machine. The tap is held in a chuck carried by the machine spindle and the work is held in the vise. When tapping nuts, it is common practice to allow each nut to feed forward onto the shank of the tap, the latter being removed each time the shank is full of tapped nuts. One type of combined threading and tapping machine is provided with a forward and reverse drive which may be engaged by pressing in or drawing back on the work, the same as with a regular type of tapping machine. The machine referred to is equipped with a cone-pulley that provides variations of speed to suit different sizes of taps, and the reverse is obtained by means of back-gearing contained within the cone-pulley.

Multiple-spindle threading machines are used in preference to the single-spindle type where large numbers of bolts, studs, or similar parts are constantly being threaded. Each spindle of a machine of this type has a separate carriage so that, while a thread is being cut on one bolt, the operator can remove the threaded part and insert a new blank in the work-holder of the nearest carriage. Some threading machines are equipped with non-opening dies, in which case the spindle is reversed for backing the die off of the work. This reversal may be obtained by the use of open and crossed belts.

Threading Machine having Speed-changing Mechanism. — The threading machine which is partly shown in Fig. 2 has a geared speed-changing mechanism so that the cutting speed of the die may easily be varied according to the diameter of the

screw being cut. The drive is to a single constant-speed pulley *B* from which motion is transmitted to the spindle through a combination of gearing, the ratio of which depends upon the position of control lever *A*. This lever is located positively by the engagement of a spring plunger which enters one of the holes shown. The position of this lever for dies of different sizes is indicated by figures located above the various holes which represent screw diameters and vary from $\frac{1}{4}$ to $\frac{3}{4}$ inch. The spindle speeds corresponding to these diameters range from 225 R.P.M. for the $\frac{1}{4}$ -inch screw threads down to 90 R.P.M. for

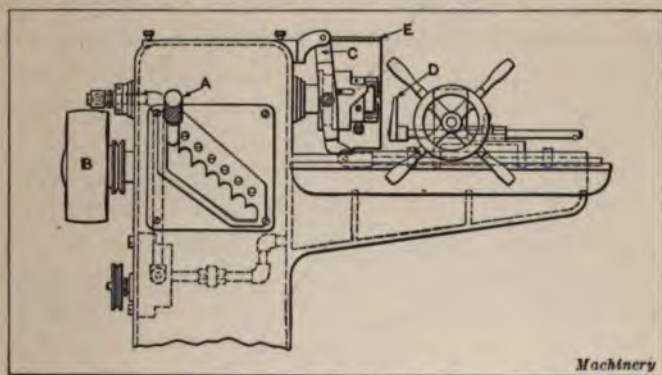

Fig. 2. Gear-driven Threading Machine equipped with Speed-changing Mechanism

the $\frac{3}{4}$ -inch size. These speeds are based on average screw-cutting practice and are subject to variation.

The spindle of the machine carries a style *D* Geometric self-opening and adjustable die-head, which is modified in design to meet the operating requirements. The die-head is held in a cam sleeve which is pivoted in a yoke *C*. This yoke is pivoted at the upper end and at the lower end connects with the rod carrying two adjustable stops which control the opening and closing of the die-head. An adjustable stop *D* is used for gaging the length of the rod, stud, or other part which is held in the vise and insures a uniform length of thread on duplicate pieces. A removable oil-guard *E* surrounds the die-head. This machine is made by the Geometric Tool Co., New Haven, Conn.

Lead-screws for Threading Machines. — Threading machines or bolt cutters are sometimes provided with a lead-screw, the purpose of which is to prevent inaccuracy in the pitch or lead of the screw thread, by imparting to a carriage a positive feeding movement instead of relying on the self-leading quality of the die. Most threading machines are not equipped with a lead-screw, because such an attachment is not necessary for cutting ordinary screw threads, such as the U. S. standard, the V-thread, or the Whitworth thread, unless the threaded part is comparatively long and it is desirable to eliminate as far as practicable the cumulative error. Machines used for threading boiler stay-bolts are commonly provided with lead-screws, and also machines

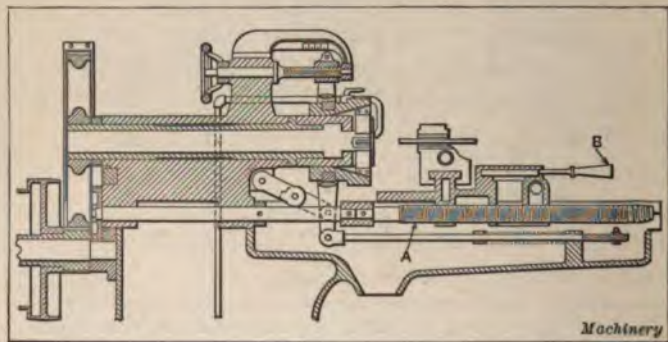

Fig. 3. Threading Machine or Bolt Cutter having a Lead-screw

that are to be used for cutting square threads or threads of special form, such as the ratchet or trapezoidal form, etc.

Whenever a lead-screw is used in conjunction with a die, it is very important to have the positive feeding movement of the carriage and work, per revolution of the die-head, equal to the pitch of the chaser teeth in the die. The function of the lead-screw is simply to prevent the die from either gaining or losing in pitch by so controlling the movement of the carriage that its advance per revolution of the die corresponds to the pitch or lead of the screw thread. The rate of the carriage movement may be controlled either by means of change-gearing, through which the lead-screw is driven from the main spindle, or by the use of a lead-screw which corresponds to the pitch of the thread to be

cut. A sectional view of an Acme bolt cutter (manufactured by the Acme Machinery Co., Cleveland, Ohio) equipped with a lead-screw is shown in Fig. 3. The lead-screw of this machine and the split nut which engages it is of the same pitch as the thread to be cut. The lead-screw *A*, which is comparatively short, is joined to the driving end of the shaft by means of a coupling. This shaft is driven directly from the main spindle through two gears. A machine of this kind may be used either continuously or for a rather extensive period on screw threads of one pitch, so that a different lead-screw in many cases is not

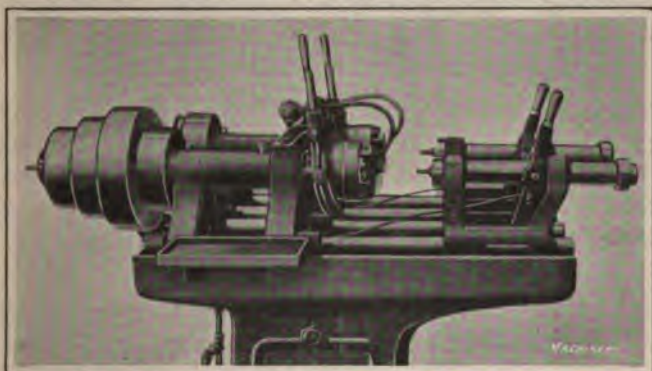

Fig. 4. Two-spindle Threading Machine having Gravity Feed for Work-holding Spindles

often required. The bronze split nut by means of which the carriage is engaged and disengaged with the lead-screw is opened or closed by a cam and hand-lever *B*. The motion of the lead-screw may be reversed for cutting left-hand threads, by moving a slide located on the headstock which changes the gearing.

Threading Machine with Gravity Feed.—An interesting type of threading machine (manufactured by Landis Machine Co., Waynesboro, Pa.), which was designed primarily for cutting threads on hollow safety set-screws or similar parts, requiring a thread the entire length of the piece, is illustrated in Fig. 4. The part to be threaded is held by a spindle which advances toward the die when cutting a thread, while the supporting member or carriage remains stationary upon the machine bed. Each

work-holding spindle is advanced toward the die-head by a weight within the machine column which is connected by a chain to the spindle operating lever. This weight exerts continuously a force upon the spindle in the direction of the die-head, so that it is unnecessary for the operator to feed the stock forward in order to start the threading operation. The spindles are fitted with suitable mandrels for holding the set-screws, and the extent of the forward movement of the spindle is controlled by an adjustable collar on the outer end. When threading set-screws, each screw blank is automatically pushed into the die-head by the action of the weight, and it passes through the die into a tube extending through the spindle. When the next set-screw leaves the die and enters the tube, it forces the finished pieces through the tube so that they fall one at a time from the end into a receptacle. This type of machine may also be utilized for ordinary bolt threading by applying automatic opening and closing attachments for operating the die-heads. For work of this class, the spindles are fitted with sockets to receive the bolt heads.

Single-Lever Control for Threading Machines.—When the blanks to be threaded have heads, holders containing pockets that receive the heads are often used in preference to a vise, because a bolt can easily and quickly be inserted or removed and it is not necessary to operate a separate handwheel or lever for opening and closing the vise. The "Namco" two-spindle threading machine which is partly illustrated in Fig. 5 is equipped with a holder of the type referred to. These holders are attached to slides which are opposite and in line with their respective threading spindles. The blanks to be threaded are inserted in the holders by hand and the pocket that receives the head prevents the blank from rotating with the die. The slide is fed forward by the vertical hand-lever shown until the die begins to cut; the lever is then released and the bolt is advanced by the action of the die itself. When the thread has been cut to whatever length the machine is set for, an adjustable stop engages a fork that engages the spool of the die which is tripped automatically. The backward movement of the slide for extracting the finished

bolt and inserting a new blank closes the die to the cutting position. This machine is applicable only for threading work which may be held by means of formed heads of square or hexagonal shape, and it is not intended for round work.

In order to secure the advantage of the single lever construction when the use of a work-holding vise is necessary, some machines are so arranged that both the vise and carriage or slide are operated by a single lever instead of having one lever or wheel



Fig. 5. Threading Machine provided with Special Blank-holders

for opening and closing the vise and another lever or wheel for moving the slide along the bed. The object of this construction is to reduce the operating time.

The single lever vise and carriage control which is applied to some of the National Machinery Co.'s bolt cutters is illustrated in Fig. 6, which shows a double- or two-spindle machine. The gear *A*, which meshes with a rack on the bed and serves to traverse the carriage, has recesses or notches formed on one side as the illustration shows. The screw for operating the vise jaws carries a disk *B*, which is also provided with notches. The lever *C* is located between this disk and the gear, and by moving

it laterally, it can be engaged either with the disk or gear for opening or closing the vise or traversing the carriage as may be required.

Vertical-spindle Threading Machines.— While most threading machines are of the horizontal type, machines having vertical spindles are used for some purposes. Fig. 17 of Chapter IV illustrates an ordinary drilling machine which has been converted temporarily into a threading machine. The rod to be threaded

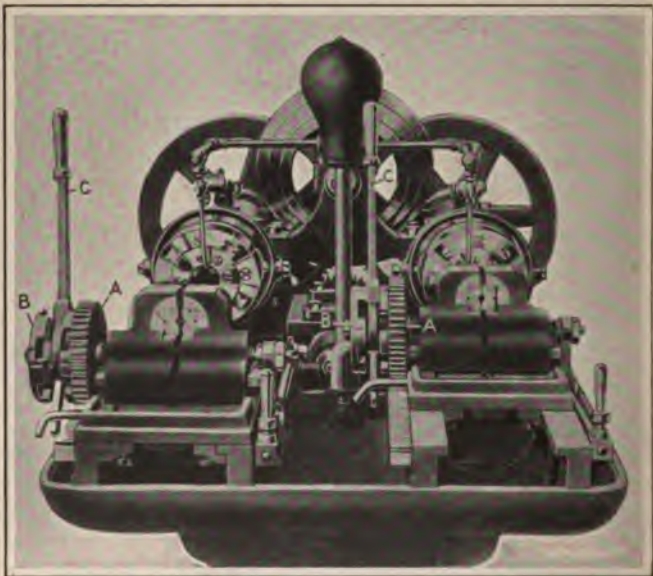

Fig. 6. Two-spindle Bolt Cutter having Single-lever Vise and Carriage Control

is held in the spindle chuck and the thread is cut by a self-opening die. This die-head is supported by a stand of sufficient height to provide clearance for that part of the rod which extends down through the die. When the thread has been cut to the required length, the die is opened by the hand-lever and the drill spindle is raised far enough for inserting another rod.

The upright drilling machine is sometimes used in conjunction with a solid or non-opening die for cutting external threads on plugs or similar parts which have a square or hexagonal end

that can be used for driving. The die is fastened in a frame or baseplate which is placed on the machine table and has enough clearance space beneath it to allow the threaded parts to fall through the die. This die-supporting frame should also have an opening that will permit removing the threaded work easily. The machine spindle is equipped with a socket form of driver that fits over the square or hexagonal end of the piece to be threaded. When cutting a thread, the spindle of the machine is simply lowered as it turns the work down through the die. This is a rapid method when applied to work of the class mentioned.

Upright Tap-threading Machine. —

The vertical machine to be described was designed especially for cutting the threads on taps. The die-head (see Fig. 7) is located beneath the vertical spindle which rotates the tap blank and is fed downward by a lead- or master-screw. The die-head consists of a combination gear and scroll chuck having special jaws and chaser holders. The chasers are of the straight-milled type and are located in a tangential position relative to the work. The spindle is rotated through worm gearing, the worm being carried by a horizontal shaft upon which the cone-pulley is mounted. The lead-screw is in the form of a threaded shell and is located on the upper end

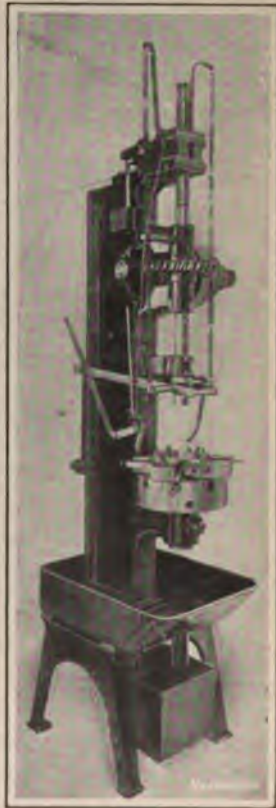

Fig. 7. Special Design of Vertical Threading Machine

of the spindle. The half-nuts which engage this lead-screw when a thread is being cut are opened or closed by a horizontal slide to which is attached a chain and weight. The lower end of the spindle is provided with a holder for driving the tap blank and, when the latter is threaded, it drops through the die.

In operating the machine, the square shank of the tap is inserted with the left hand in the driving dog at the end of the spindle and the latter is pulled down by grasping with the right hand a short cross-handle at the front of the spindle. When the tap enters the die the left hand is free to pull over the lever seen at the side of the machine, which engages the half-nuts with the lead-screw. The tap blank is then turned down through the die, and just after the threaded part leaves the die, a trip operates the arm controlling the half-nuts and releases the spindle, which is

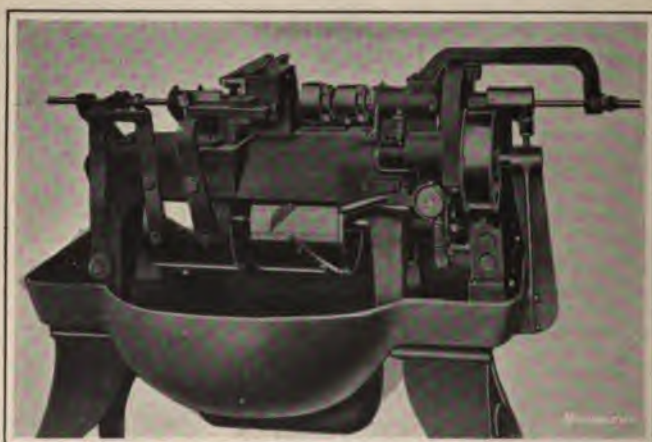

Fig. 8. Automatic Stud-Threading Machine having a Horizontal Magazine

returned to the upward position by the coil springs seen at the side of the machine. The manufacturer of this type of machine (Bickford Machine Co., Greenfield, Mass.) recommends that they be used in pairs, one machine being used for roughing and the other for finishing cuts. The use of a hobbed chaser die is also recommended for taking the finishing cuts. When taking the second cut, the tap should be held very loosely in the driving holder or dog so that it will start properly in the die before the half-nuts engage the lead-screw.

Stud-threading Machines. — The stud-threading machine illustrated in Fig. 8 is an example of the development in the design of threading machines for high-speed operation on one class of

work. This machine is intended especially for cutting the threads on studs. These studs are dropped into a horizontal magazine from which they are fed through a receiving tube by means of a push-rod. When the die is opened, the jaws holding the threaded piece recede, allowing the work to drop out and instantly another blank is fed up to the stop. This stop is supported in the spindle and is held stationary. It is adjusted from the rear of the spindle by a lock-nut. The extraction of the threaded stud and the feeding in of a new blank occur at practically the same time. The thread cutting is done with a

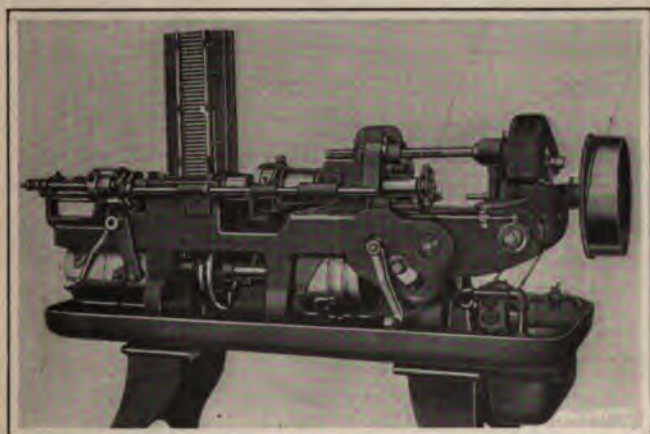

Fig. 9. Automatic Stud-Threading Machine provided with a Vertical Magazine

“ Namco ” self-opening die-head and the work is held stationary, as the threading die revolves. The die is not forced onto the stud, but follows the lead of the thread until the stop set for gaging the length of the thread causes the die chasers to open. The die is next withdrawn from the work without reversing, and it is then closed preparatory to threading the next stud. The rate of production is controlled by a system of change-gears. The movements for feeding, chucking, and extracting the stud blanks and operating the die-head are derived from cam-drums, which may be seen beneath the machine in the illustration. The spindle speed for various diameters of work is controlled by

back-gears arranged to maintain a cutting speed of approximately 35 feet per minute for various diameters. The number of pieces that can be threaded in ten hours with this machine ranges from 6900 to 39,500, the rate of production varying with the diameter of the work. This production is based on a continuous operation of the machine for the time specified. This machine has a capacity for diameters varying from $\frac{1}{4}$ to $\frac{1}{2}$ inch in diameter, inclusive.

Automatic Threader of Vertical Magazine Type. — The automatic threading machine to be described may be used to thread studs which have been finished on one end in a screw machine or for threading both ends of a blank. This machine (see Fig. 9) which has a capacity varying from $\frac{1}{2}$ to 1 inch in diameter, inclusive, may also be applied to other classes of work of the same general size and shape. The single-belt pulley seen at the right-hand end of the machine transmits motion through a system of change-gears to the cam-drums. One of these drums controls the feeding operation and the other the advance of the slide carrying the die. The magazine is of an upright or vertical type, which is loaded at the top by the operator. The stud blanks pass from the bottom of the magazine, one at a time, into a receiving tube located just back of the chuck, this feeding action being derived from a cam-controlled movement of the feed-in slide. Each successive stud is forced from this tube into the chuck by a push-rod working from the rear. As the new blank is being inserted, the threaded one is automatically extracted as the die recedes. The machine is adapted for threading studs of different sizes by equipping it with a die and chuck of suitable capacity and by adjusting the guide walls of the magazine both with reference to the diameter and length of the work. The spindle tube is only changed for the extreme variations in size. The stud-threading machines shown in Figs. 8 and 9 are made by the National Acme Co., Cleveland, Ohio.

CHAPTER X

THREAD MILLING

THE formation of screw threads by means of a rotating cutter or by the milling process has been practiced for nearly half a century, but the real development of thread milling is relatively modern as marked by the introduction of efficient machines constructed especially for doing this work on a manufacturing basis. A great many screw threads that formerly were cut with a single-pointed tool in an engine lathe are now milled. Thread milling has also proved superior to the use of dies or taps for certain external and internal screw-cutting operations. Before considering the relative advantages of the thread-milling process as compared with other screw-cutting methods and the particular classes of work for which thread milling is especially adapted, the different methods of forming screw threads by milling and various types of thread milling machines and attachments will be described.

Milling Threads with Single Cutter. — There are two general methods of forming screw threads by milling, which may be designated as the single-cutter and the multiple-cutter methods. The way a single cutter is used is indicated by the diagram, Fig. 1. The profile of the cutter or the shape of its cutting edge conforms to the sectional shape of the thread groove. This cutter should revolve as fast as possible without dulling the cutting edges excessively, in order to mill a smooth thread and prevent unevenness such as would result with a slow-moving cutter on account of the tooth spaces. As the cutter rotates, the part on which a thread is to be milled is also revolved, but at a very slow rate (a few inches per minute), since this rotation of the work is practically a feeding movement. The cutter is ordinarily set to the full depth of the thread groove and finishes a single thread in one passage, although deep threads of coarse pitch may need two

or even three cuts. For work of this kind a roughing cut is sometimes taken with a special cutter which is somewhat narrower than the finishing cutter.

Whenever a single cutter is used, the axis of the cutter is inclined to some angle α instead of being parallel to the axis of the screw, in order to locate the cutter in line with the thread groove at the point where the cutting action takes place. (Tangent of angle $\alpha = \text{lead of screw thread} \div \text{pitch circumference of}$

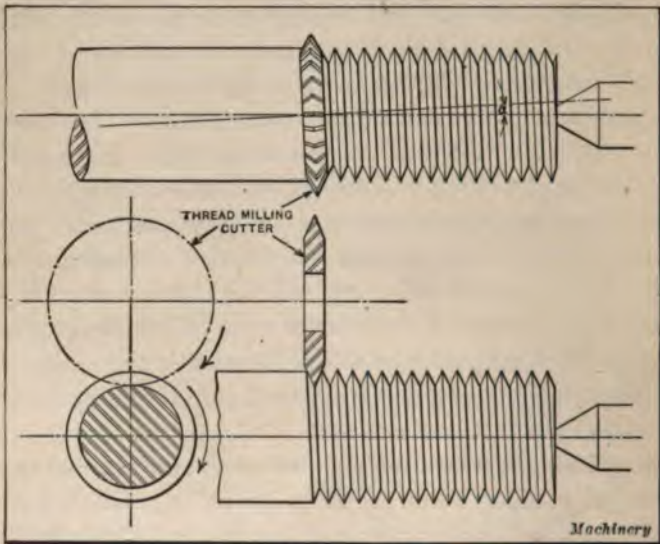

Fig. 1. Diagram illustrating Method of milling Screw Thread with a Single Cutter

screw.) The helical or "spiral" thread groove is generated in practically the same way as when an engine lathe is used. In the case of a thread milling machine, however, the lengthwise traversing movement is applied to the cutter on some machines and to the screw being milled on other machines. For instance, the revolving cutter may be traversed in a direction parallel to the axis of the work a distance equal to the lead of the thread for each revolution of the screw blank, or this order may be reversed, the cutter revolving in one position while the screw blank moves in a lengthwise direction as it slowly rotates.

These variations in the design of different thread milling machines will be considered later. The single cutter process is especially applicable to the milling of large screw threads of coarse pitch, multiple threads, and the heavier classes of work. For fine pitches and short threads, the multiple-cutter method to be described is preferable, because it is more rapid.

Milling Threads with Multiple Cutter. — The second thread milling method referred to, which requires the use of a multiple cutter, is illustrated by the diagrams *A* and *B*, Fig. 2. This multiple cutter is practically a series of single cutters, although

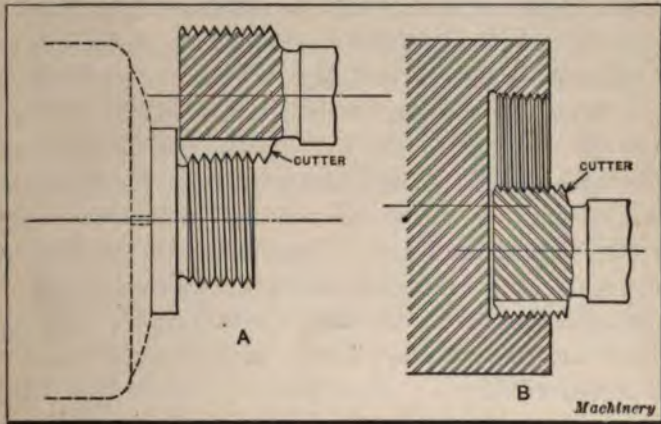

Fig. 2. Examples of External and Internal Thread Milling with a Multiple Type of Cutter

formed of one solid piece of steel, at least so far as the cutter proper is concerned. The annular rows of teeth do not lie in a helical or spiral path, like the teeth of a hob or tap, but coincide with planes which are perpendicular to the axis of the cutter. If the cutter had helical teeth the same as a hob, it would have to be geared to revolve in a certain fixed ratio with the screw being milled, but a cutter having annular teeth may rotate at any desired speed, while the screw blank is rotated slowly to provide a suitable rate of feed. (The multiple cutters used for thread milling are frequently called "hobs," but in this chapter the term hob will be applied only to cutters having helical teeth.)

The object of using a multiple cutter instead of a single cutter is to finish a screw thread complete in approximately one revolution of the work, a slight amount of over-travel being allowed to insure milling the thread to the full depth where the cut joins the starting point. In order to finish the thread complete in one revolution (plus the over-travel referred to), it is necessary to use a cutter which is at least one or two threads or pitches wider than the thread to be milled. When using a multiple cutter it is simply fed in to the full thread depth and then either the cutter or screw blank is moved in a lengthwise direction a distance equal to the pitch of the thread. Since there is an annular row of cutting teeth for each thread groove, this movement equal to the pitch is sufficient to finish the entire thread in one revolution of the work, plus whatever additional movement there might be due to the over-travel. If an exceptionally smooth thread were required, the work might be revolved two revolutions and the cutter be traversed a distance equal to twice the pitch of the thread. During the first revolution the thread would be rough-milled and a light finishing cut would then be taken while the work made a second revolution. Sketch *B*, Fig. 2, illustrates the application of a multiple cutter to internal thread milling.

It is apparent that the length of the thread that can be milled by the multiple-cutter method is limited, because the cutter is supported at one end only and it would be deflected considerably if the length of the cutting end and the "over-hang" were increased to any great extent. As the cutter is milling along the entire screw thread at the same time, the lateral thrust is relatively large as compared with a single cutter operating on a thread of corresponding pitch; therefore, the multiple cutter is used for milling comparatively short threads and usually for medium or fine pitches.

Position of Multiple Cutter Relative to Work. — When using multiple cutters either for internal or external thread milling, the axis of the cutter is set parallel with the axis of the work, instead of inclining the cutter to suit the helix angle of the thread, as when using a single cutter. Theoretically, this is

not the correct position for a cutter, since each cutting edge is revolving in a plane at right angles to the screw's axis while milling a thread groove of helical form. It might be supposed that there would be serious interference between the cutter and the thread, and as a result a decided change in the standard thread form. In practice, however, the defect is very slight and may be disregarded except when milling threads which incline considerably relative to the axis, as when the pitch is large in proportion to the diameter or the thread is of the multiple form and has a large helix angle. Threads which have steeper sides than the U. S. standard or Whitworth forms should ordinarily be milled with a single cutter, assuming that the milling process is preferable to other methods. For instance, when cutting an Acme thread which has an included angle between the sides of 29 degrees, there might be considerable interference if a multiple cutter were used, unless the diameter were large enough in proportion to the pitch to prevent such interference. If an attempt were made to mill a square thread with a multiple cutter, the results would be very unsatisfactory owing to the interference. If a multiple cutter, in any case, were inclined to align it with the thread groove, the same as is done when the single form of cutter is employed, the advantage of the multiple type would be lost, and instead of finishing the thread in one revolution of the screw blank, it would be necessary to traverse the cutter along the entire length of the thread.

Interference between the cutter and work is more pronounced when milling internal threads, because the cutter does not clear itself so well. Experiments have shown that multiple cutters for internal work should preferably not exceed one-third the diameter of the hole to be threaded. A cutter that is one-quarter the diameter of the thread will do very satisfactory work. It is preferable to use as small a cutter as practicable, either for internal or external work, not only to avoid interference, but to reduce the strain on the driving mechanism.

Direction of Cutter Rotation. — It is the general practice when milling threads in steel, cast iron, and brass to revolve the cutter and screw blank so that they are moving in opposite

directions on the cutting side. For some thread milling operations, however, it is preferable to rotate the work and the cutter so that they travel in the same direction on the cutting side. For instance, when milling threads in aluminum castings, celluloid and parts made of fiber, smoother and better threads will be obtained if the cutter and work revolve together, the same as two gears in mesh, except that the cutter revolves quite rapidly, while the part being milled has a slow feeding movement.

Milling Multiple Threads. — If a multiple thread is to be milled with a single cutter, the method followed is practically the same as when using a single-point tool in the lathe. The machine is arranged to give a lengthwise traversing movement equal to the lead of the thread (not the pitch), and then, after a single thread groove is milled, the screw blank is indexed a half revolution for milling the second thread groove, assuming that a double thread is required. Thread milling machines and attachments are commonly provided with means for indexing when cutting multiple screw threads.

Multiple threads can readily be milled with the multiple style of cutter, although in some cases difficulty may be experienced due to interference between the cutter and the sides of the thread. Such interference is more likely to occur in the case of a multiple thread on account of the increased helix angle. In order to mill a multiple thread, it is simply necessary to arrange the machine so that the work is advanced a distance equal to the lead of the thread instead of the pitch, the same as when using a single cutter for milling a multiple thread. In other words, the advance movement of the cutter or work, as the case may be, should be equivalent to the distance that one of the single threads advances in a complete turn. Another way to cut a multiple thread would be to use a cutter having a pitch equal to one-half the pitch of the lead-screw, assuming that the machine was of a type controlled by the direct action of the lead-screw on the spindle.

Classes of Work for Thread Milling Machines. — Determining when the thread-milling process is superior to other thread-cutting methods may be very easy in some cases and very diffi-

cult in others. Each standard method of cutting threads, whether by milling, by means of taps and dies, or by using a single-point tool in the lathe has its own advantages when applied under favorable conditions. The chief competitors of the thread milling machine are the engine lathe, dies for external threads, and taps for internal thread cutting. A thread milling machine may be used (1) because the pitch of the thread is too coarse for cutting with a die, (2) because the milling process is more efficient than using a single-point tool in a lathe, (3) in order to secure a thread which is smoother and more accurate as to lead than would be obtained with a tap or die, (4) or because the thread is so located relative to a shoulder or other surface that milling is superior to any other method if not the only practicable way of doing the work.

When making comparison between thread-cutting processes, it is also essential to consider the relation that may exist between the thread-cutting operation and other operations which may precede it. To illustrate this point, a lathe may be inferior to a thread milling machine for cutting a thread of a certain size and pitch, and yet the lathe may be preferable because cutting the thread is only one of a series of operations, and by doing this work in the lathe the piece is finished at one setting and the thread is accurately located with reference to other machined surfaces. Similar conditions may exist in connection with work done in turret lathes or screw machines. For example; when a part requiring an internal thread is turned and bored in a turret lathe, there is a decided advantage, in most cases, in finishing the part without removing it from the chuck and, ordinarily, some form of tap would be used, or a die in the case of external threads. In view of this close relationship between the method of cutting the thread and the work as a whole, it is apparent that any comparison between thread milling and other thread-cutting processes must be general and subject to modification. The classes of work for which the different thread-cutting methods are particularly adapted also merge into one another and there is no well-defined dividing line to serve as a guide.

Determining the relative merits of different thread-cutting

processes is further complicated by the fact that a comparison between thread milling and the use of a lathe, die, or tap might be based either on the rate of production, accuracy of thread as to diameter and lead, smoothness of thread, or its location relative to other surfaces. The importance of these different features may vary considerably on different classes of work. It might be possible to obtain a much higher rate of production with a die than with a thread milling machine of the single-cutter type, but milling might be preferred in order to secure screw threads having a higher degree of accuracy as to lead than is usually obtained with a die.

Effect of Diameter, Pitch, and Torsional Strain on Method of Cutting Thread. — As the diameter and pitch of threads increase beyond the ordinary sizes, the use of dies for external work and taps for internal work becomes less practicable. If the screw is of large diameter, a die or tap must also be large and cumbersome, and the cost of these tools for cutting one size and pitch of thread may be prohibitive in view of the amount of work to be done. If a large number of duplicate threads are required, dies or taps may be used in preference to any other method, even though the diameter is large, especially if the pitch of the thread is not so coarse as to cause distortion of the work as the result of torsional strain when cutting. Some parts such as sleeves, collar-nuts, etc., are difficult to hold firmly enough for tapping without distortion, but work of this kind can easily be handled on a thread milling machine. As a general rule, the best method of cutting large screw threads of coarse pitch, multiple-threaded screws, or any form or size of thread requiring the removal of a relatively large amount of metal is by means of a thread milling machine equipped with a single cutter. The milling process is particularly desirable if the pitch of the thread and size of the thread groove are large in proportion to the diameter of the screw, because the metal removed by each cutting edge around the circumference of the cutter during one revolution is small and the screw being milled is not subjected to any great torsional strain. When a die is used for work of this kind, the accuracy of the screw may be seriously affected

by the torsional strain or the twisting of the screw blank when cutting the thread. In some cases, duplicate screws large enough as to diameter and pitch to come well within the range of the single-cutter type of thread milling machine are cut by dies, because a greater production is obtained and the finish and accuracy of the threads are within the allowable limits.

Advantages of Thread Milling Machine as Compared with Lathe.—The single-cutter type of thread milling machine is superior to the lathe for cutting threads on lead-screws, worms, etc., because it gives a higher rate of production due to the fact that the action of the milling cutter is continuous and a single cut usually finishes the thread complete. The thread milling machine has little, if any, advantage over the lathe in regard to accuracy of lead since both machines duplicate the controlling lead-screw. The heat generated when cutting the thread may, however, affect a screw cut in the lathe more than one that is milled. When milling a screw, the blank revolves very slowly and the small amount of heat generated by the cutter is localized, so that it can readily be dissipated by using sufficient oil or cutting compound. As the single-point tool moves along more rapidly, there is liable to be a greater expansion of the screw, which, when cold, may not be as accurate in regard to lead as a screw that has been milled. The rotating milling cutter is also more durable than a single-point tool, and it can be used for cutting longer screw threads without sharpening and relocating the tool; moreover, the cutter is superior in maintaining a given diameter.

The accuracy of a milled screw may depend upon several factors, such as the accuracy of the lead-screw on the machine, the condition of the cutter, the quality of the material of which the screw is made, the amount of oil or other cooling medium that is supplied, the accuracy of the diameter of the screw blank, and the rate of feed. According to the Pratt & Whitney Co., lead-screws, when milled under favorable conditions, in most cases will not show an error of over 0.001 inch in any foot of their length. For accurate work of this kind, it is very important to use stock that is uniform in diameter and a good fit

in the follow-rest bushing of the machine; in fact, screws that are to be milled should be ground if they are to run in a follow-rest bushing. Certain kinds of steel which, because of their composition, are difficult to cut smoothly with a stationary tool in a lathe are easily cut by milling.

Thread milling machines as a class have a further advantage, particularly as compared with the engine lathe, in that they are easier to operate and can be handled by unskilled labor. The fact that these machines are usually semi-automatic also makes it possible for one operator to attend to two or more machines on many classes of work. The number of machines that one man can operate to advantage depends partly upon the time required for milling the thread in one machine. For instance, with a certain type of thread milling machine, if the actual milling time exceeds forty seconds, it is possible for an operator to run two or more machines.

Application of Multiple-cutter Thread Milling Method.—As the multiple-cutter type of thread milling machine is applied to different classes of work than a machine having a single cutter, its relation to other thread-cutting methods is quite different. For work within its range, a multiple-cutter machine frequently comes into competition with dies and taps, especially self-opening dies and collapsing taps. For some thread-cutting operations, it is generally conceded that the milling process is superior and more efficient than any other method. There is a decided difference of opinion, however, regarding the relative merits of these methods of cutting threads, particularly as applied to classes of work which are within the range of either the thread milling machine or a die, if the thread is external, and a tap if it is internal. The multiple-cutter type of thread milling machine has been used extensively in preference to collapsing taps when the thread must be cut close up to a shoulder or close to the bottom of a hole, as, for example, when cutting the threads, for the base plugs in shells. The sketches in Fig. 2 represent typical examples of external and internal work for which the multiple-cutter type of thread milling machine has proved very efficient, although its usefulness is not confined to shoulder work

and "blind" holes. The milling cutter is used frequently in preference to a tap, because it produces a smoother thread, especially if the metal has soft stringy spots.

The diameter of the hole to be tapped and its length often have a decided effect upon the preferable method of cutting threads, especially when comparing the multiple type of thread milling cutter with taps. The smaller the hole and the greater its length, the less practicable the milling process becomes. If the cutter is too large in proportion to the diameter of the hole to be threaded, the cutter does not clear itself, and if it is too long in proportion to the diameter, there is not enough rigidity for

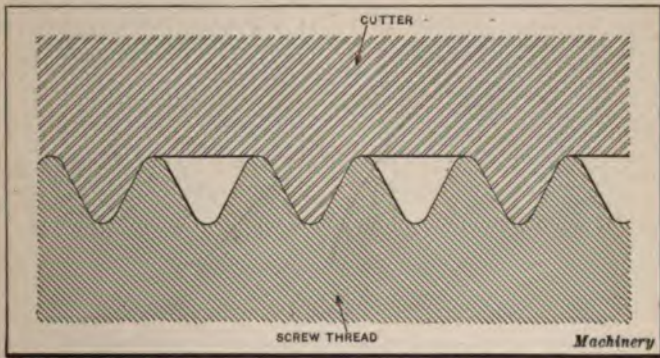

Fig. 3. Enlarged Sectional View, showing Multiple Cutter with Alternate Rows of Teeth removed for Milling Comparatively Long Screw Threads

milling a straight and accurate thread, the cutter being deflected in a lateral direction. The limitations of the milling cutter as regards rigidity are subject to considerable variation and may be affected decidedly by the design of the machine, its condition, and whether the material being milled is hard and tough, or soft and easily cut.

A simple method of increasing the maximum length of thread which can be milled with a multiple cutter is illustrated by the diagram, Fig. 3. Every other row of cutter teeth is omitted, the distance between the teeth being equal to twice the pitch of the thread to be milled. By using a cutter of this kind, the lateral thrust or pressure is greatly reduced and a complete

thread is milled by simply allowing the work to make two revolutions (plus the necessary over-travel) instead of one revolution.

Milling Short Threads Close to a Shoulder.— Very short threads, especially when close to a shoulder, are difficult, if not impossible, to cut by means of taps or dies, particularly when power is utilized for performing the operation. The throat of a die or the chamfer of a tap leaves that part of the thread adjacent to the shoulder unfinished, and if the throat or chamfer are omitted, all of the work is done by the first row of teeth, which is objectionable. The milling process is very effective for this kind

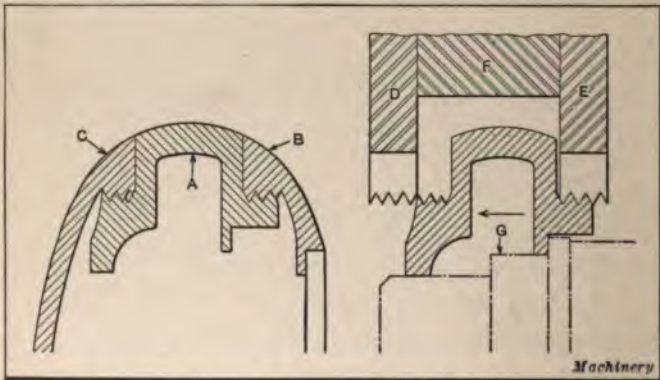

Fig. 4. Use of Duplex Cutter for Milling Very Short Threads close to a Shoulder

of work, even though only two or three threads are required, and the strength of the part will not permit cutting a recess or clearance space at the end of the thread.

An example of work illustrating the possibilities of the thread milling machine for milling very short threads close to a shoulder is shown on an enlarged scale in Fig. 4. The thread milling operation to be described is on the central section *A* of a watch case. This central part requires a thread on both sides for receiving the bezel *B* and back of the case *C*, as indicated by the assembled view. The thread has a pitch of $\frac{1}{54}$ inch (54 threads per inch) and a diameter of 1.800 inch. Each thread makes one and one-half turn approximately, or, in other words, there is one and one-half thread on each side, and both of these threads are

milled at the same time by a duplex cutter of the multiple type. The cutters *D* and *E* are separated by a collar or distance piece *F* which is just wide enough to allow for the necessary feeding movement of the work. This operation is performed on a Thomson semi-automatic thread milling machine similar to the type shown in Fig. 15 of Chapter XI. This machine is so arranged that the work-spindle is moved longitudinally by the direct action of a lead-screw when milling a thread. For this particular operation, the cutter-slide is adjusted so that one of the cutters just clears the shoulder. As the thread is milled, the work-spindle and work move in the direction indicated by the arrow, so that cutter *E* operates from the shoulder outward, whereas cutter *D* moves inward. This is a sharp V-thread having a 60-degree angle. The work is held in position on an expanding arbor *G* having shoulders for accurately locating it. These pieces were milled in this way at the rate of 160 per hour. The back *C* and bezel *B* of the case are also threaded on the same type of machine.

Screw Threads which must Qualify or Register with a Machined Surface. — Thread milling is also especially applicable whenever screw threads on duplicate parts must “qualify” or maintain an exact relation with a fixed point or surface on the work. The external threads on rifle barrels and internal threads in receivers into which the barrels are screwed are examples of work requiring threads accurately located, relative to a shoulder in the case of a barrel and a finished face in the case of a receiver.

Examples of the kind of work that requires great accuracy in regard to the location of the threads are shown in Fig. 5. The thread on the rifle barrel, the end of which is shown at *A*, must not only be accurate as to diameter and pitch, but must qualify or register with the shoulder *a*. The internal thread in the receiver shown at *B* must also be accurately located with reference to the finished face *b*. When the rifle is assembled, the barrel screws into the receiver and if both threads did not register properly, the barrel would not be in the right position when screwed up against the shoulder. For instance, if the thread did not start at the right place and was, therefore, in a

different location relative to the shoulder, the sight on the barrel (or the seat for an attached sight) when the latter is assembled, would not be in a vertical position or at the top.

The receiver shown at *B* has, in addition to the internal thread, an external thread which must qualify with a shoulder *c*. This particular receiver is for a Mauser rifle which has an outer tube or casing surrounding the barrel instead of the wooden grip such as is found on most military rifles. As this outer tube carries the sight, it is essential to have the thread accurately located with reference to the shoulder. For all work of this general nature, the thread milling machine is particularly adapted.

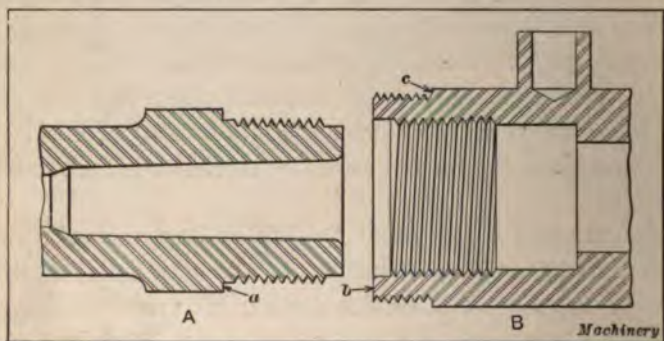

Fig. 5. Screw Threads on Rifle Barrel and Receiver which must qualify or register accurately with Other Surfaces

Cutter Interference when Milling Square Threads. — It is difficult and often impossible to mill a satisfactory square thread, even when using a single cutter, owing to the interference between the cutter and the sides of the thread. The Acme thread, which is superior to the square thread, may be milled very easily with a single cutter, and is now used extensively for lead-screws and on many other parts which formerly had the square thread. The trouble due to cutter interference when milling square threads is more pronounced if the thread is a multiple form and, therefore, has a greater lead angle. The cutter should preferably be set to the helix angle of the thread at a point midway between the top and bottom of the thread groove. If the cutter is set to the angle at the bottom of the thread, the groove will be

milled wider toward the top and have slightly curved sides. On the contrary, if the cutter is set to the angle at the top of the thread, the sides of the thread groove will be under-cut somewhat. A burr may also be formed by the cutter especially after the corners become dull. Trouble due to interference may sometimes be partly avoided by grinding the sides of the cutter slightly tapering or to an angle of from three to five degrees. Interference of the kind referred to does not occur when milling

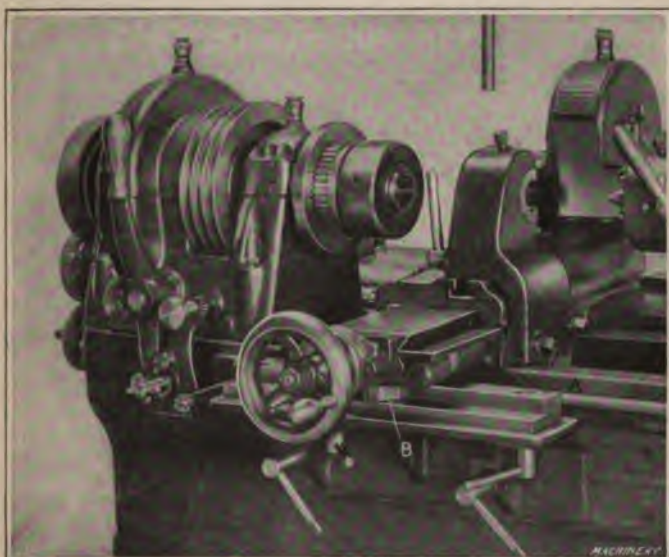

Fig. 6. Taper Attachment applied to a Pratt & Whitney Thread Milling Machine

threads having angular sides, because the cutting edges readily clear the angular sides after leaving the cutting position.

Milling Taper Threads. — The milling of taper screw threads may be done on a single-cutter type of machine by traversing the cutter laterally as it feeds along in a lengthwise direction, the same as when using a taper attachment on an engine lathe. The taper attachment which is applied to some Pratt & Whitney thread milling machines is illustrated in Fig. 6. When the attachment is in use the cutter-slide is controlled by a guide-bar *A*.

This guide-bar is inclined relative to the axis of the screw; it is engaged by a sliding block *B* on the front side and a roller on the rear side, which constrain the cutter to follow an angular or tapering path. This guide-bar is formed of two sections; by setting one of these sections parallel to the axis of the screw and the other to an angle, both tapering and straight screw threads can be milled. This feature is sometimes required when milling the threads on certain classes of taps having tapering

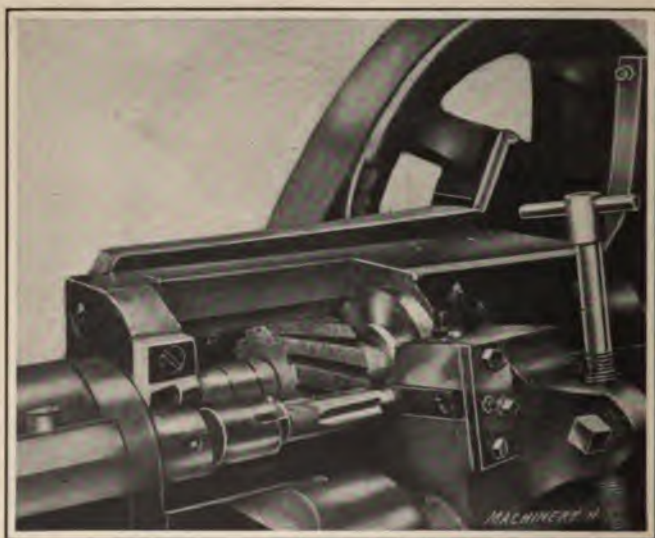

Fig. 7. Milling and relieving simultaneously a Tapering Tap by Means of a Multiple Cutter

ends followed by a straight section. The roller is held into contact with the rear side of the guide-bar by means of a spring which permits the use of a jointed guide-bar.

Taper threading on the thread milling machine can also be done when using the multiple type of cutter. One method of using a multiple cutter on tapering work is illustrated in Fig. 7, which shows a detailed view of a special machine used for cutting threads on taper taps. This particular machine is so arranged that it not only mills a tapering thread, but relieves it at the same time. The cutter is similar to the multiple type previ-

ously described in that it has annular rows of teeth which lie in planes perpendicular to the axis and are not helical like the teeth of a hob; the flutes are helical in this case instead of being straight or parallel to the axis. When a thread is being milled, the tap moves in a lengthwise direction as it revolves, at a rate depending upon the pitch of the thread for which the tap is intended. The teeth of the tap are relieved as the result of an oscillating motion which is given to the multiple cutter. Each time the tap revolves, a complete cut is taken across every tooth so that two or three revolutions provide for both roughing and finishing cuts. The square end of the tap shank is finished before milling the thread so that this end can be inserted in a socket and used for driving the tap, while the other end is supported upon a conical center. This center is adjustable so that the tap can be located at the correct angle relative to the multiple cutter.

Speeds and Feeds for Thread Milling. — The rate of production obtained with a thread milling machine may be affected greatly by the requirements as to accuracy and finish of the milled threads. The quality of the work depends considerably upon the speed of the cutter and its relation to the feed. If the speed of the cutter is too slow for a given feed, the thread will not be finished as smoothly as it would be if a greater number of cutting edges passed the cutting position during a given feeding movement of the screw; therefore, to obtain a high rate of production and, at the same time, a smoothly finished screw thread, the cutter should revolve as rapidly as possible without dulling it excessively, and for this reason high-speed steel cutters are generally used for thread milling operations, although carbon steel cutters are preferable for milling such materials as aluminum, bronze, and fiber, as they will cut smoother threads. The surface speed of the screw blank may not exceed 2 or 3 inches per minute, if the material is tough and especially if the thread is of rather coarse pitch; on the contrary, the surface speed may be increased to 6 or 8 inches per minute when the pitches are finer and the material cut more easily. Faster feeding movements are also used under favorable conditions.

The speed of the milling cutter usually varies from 100 to 125 feet per minute, with slower and faster speeds for some thread milling operations. The design of the machines and the general type may affect the speeds and feeds to some extent. The feeds and speeds recommended by the manufacturer of a single-cutter type of thread milling machine when equipped with a high-speed steel cutter are as follows: A surface speed for the cutter of about 100 feet per minute is a fair average speed for milling threads in machine steel, whereas, for tool steel, the

Speeds and Feeds for Thread Milling

Cast and Tool Steel	Machine Steel and Bronze	Wrought Iron	Cast Iron	Malleable Iron	Gun Metal	Aluminum	Brass
Cutting Speeds (Feet per Minute) for High-speed Steel Cutters							
70-100	135-155	140-160	145-165	155-175	170-190	180-220	200-240
Cutting Speeds (Feet per Minute) for Carbon Steel Cutters							
30-45	50-70	60-80	60-80	70-90	80-100	85-105	90-110
Feeding Movement of Work (Inches per Minute) for High-speed Steel Cutters							
5-8	6-9	8-10	10-15	10-15	15-20	20-30	20-30

speed should be reduced to about 70 feet per minute. When milling threads of moderate pitch such as 5 threads per inch and finer, the rate of feed is regulated somewhat by the quality of the finish desired. When milling threads in machine steel and using a cutter $2\frac{1}{4}$ inches in diameter, a speed of 177 revolutions per minute is considered satisfactory, and a feed of about $4\frac{1}{2}$ inches per minute provided there are 5 threads per inch or more; if the thread is coarser, say, 3 or 4 threads per inch, the feed should be reduced to 3 or $3\frac{1}{2}$ inches per minute, and for 2 or $2\frac{1}{2}$ threads per inch, to 2 or $2\frac{1}{2}$ inches per minute. When milling tool steel, slower feeds are recommended; when milling brass, much higher speeds and feeds may be employed. According to another manufacturer, a speed of about 125 feet per minute is approxi-

mately the maximum speed for tool-room work in steel, whereas for manufacturing operations, especially when milling soft steel, the speed may be considerably higher. When milling lead-screws or other accurate screws, it is preferable to feed rather slowly so that the stock may be thoroughly cooled, in order to avoid errors due to expansion and contraction. The cutter must also be kept sharp to prevent expansion or distortion of the stock due to the swaging action and the friction generated by the dull teeth. The condition of a cutter should be noted before beginning to mill a long screw, so that it need not be changed until the milling operation is finished.

A manufacturer of a thread milling machine of the multiple-cutter type recommends a feed of 6 inches per minute and a cutting speed of from 75 to 80 feet per minute when milling threads in soft steel. In fact, the feed and speed mentioned have been used when milling 8 threads per inch or more in steel containing 0.55 per cent of carbon. The feed for this work has also been increased to 9 inches per minute with satisfactory results. When milling threads of $\frac{1}{4}$ inch pitch in nickel steel, a feed of 2 inches per minute and a cutting speed of about 50 feet per minute were utilized. While this is exceptionally heavy work for a multiple-cutter machine, the possibilities and limitations in any case may vary greatly, since the rigidity of a machine, its condition, and the relation between the diameter of the cutter and its length are very important factors.

The speeds and feeds recommended by still another manufacturer of a multiple-cutter type of machine are given in the accompanying table which applies to a number of different materials, ranging from tool steel to brass. It is claimed that the speeds and feeds for a thread milling machine may be from 20 to 40 per cent faster than could be used when milling flat surfaces in connection with regular milling machine work. If the best results are to be obtained, cutters must be kept sharp as they will last longer, consume less power, and produce more and better work. As form cutters are used, the face of each cutting tooth should be ground radial to obtain the correct form of thread.

CHAPTER XI

THREAD MILLING MACHINES AND SPECIAL ATTACHMENTS

THREAD milling machines may be classified according to the kind of cutter used, that is, whether single or multiple, and also with reference to the method of obtaining a lengthwise feeding movement for generating the thread. Some machines are so designed that the cutter-slide or carriage is traversed along a horizontal bed by a lead-screw which is connected to the work-spindle through change-gears, the arrangement being practically the same as on an engine lathe. With this general type of machine, the cutter (which may be single or multiple) moves along one side of the work, while the latter rotates but remains in one position. This order is reversed in another general type of milling machine which is designed to move the part on which a thread is to be milled, in an axial or lengthwise direction, while the cutter-slide remains stationary, except when it is traversed laterally or at right angles to the screw thread for moving the cutter in or out of the working position. A machine of this kind may have a work-table which is traversed by a gear-driven lead-screw, or the traversing motion may be imparted to the work-holding spindle either by the direct action of a lead-screw or by a lead-screw and gearing combined. When a lead-screw is applied directly to the work-spindle, the lead of its thread is the same as the lead of the thread to be milled, and different lead-screws are used for milling threads of different pitches. Some of these "duplicating" machines are designed especially for milling threads on large numbers of duplicate parts, and they are less complicated than a machine equipped with change-gears and arranged for milling threads of different pitches. Other machines which derive the traversing motion directly from a lead-screw are so constructed that one lead-screw may easily be replaced with another of different pitch.

Such machines are intended for general application, but lead-screws are changed for milling threads of different pitch, instead of change-gears, as in the case of the other general type of machine mentioned. Thread milling machines embodying the general principles of operation outlined differ, of course, in regard to the arrangement as well as to the details of construction, as shown by the following descriptions.

Pratt & Whitney Thread Milling Machine.— One design of thread milling machine having a gear-driven lead-screw and a

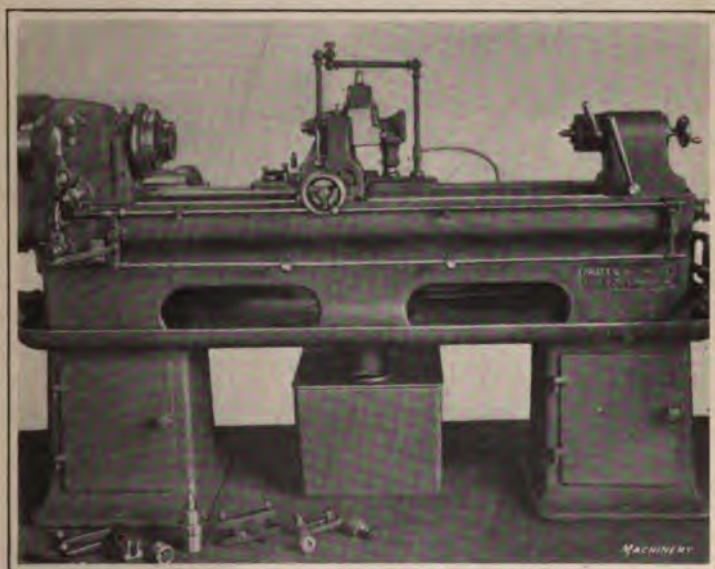

Fig. 1. Pratt & Whitney 6-by 48-inch Thread Milling Machine

traversing cutter-slide is shown in Fig. 1, which illustrates a 6-by 48-inch machine manufactured by Pratt & Whitney Co., Hartford, Conn. This machine is driven by a belt connecting with a cone-pulley carried by a horizontal shaft extending along the rear side of the bed, as shown in Fig. 2. This shaft drives the work-spindle through a gear-box which provides for the necessary speed changes. The lead-screw for traversing the cutter-slide is connected to the work-spindle by change-gears selected with reference to the pitch or lead of the thread to be

milled. The rear view illustrates how motion is transmitted from the driving shaft to the cutter-spindle through bevel gearing and suitable connecting shafts. The main driving shaft at the rear is splined to permit the cutter-slide to move along the bed. The cutter-slide has a rapid traversing movement and automatic stops for controlling the length to which a thread is milled.

The work-spindle is indexed when cutting multiple screw threads by a notched ring attached to the inner section of the

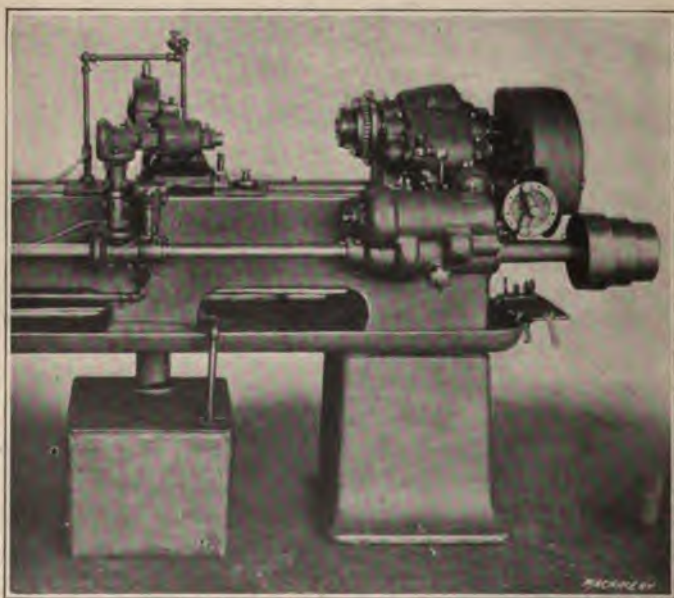

Fig. 2. Rear View of Pratt & Whitney Thread Milling Machine

compound work-spindle. The outer section of this spindle is normally locked to the inner part by a pawl which engages a notch in the ring referred to. In order to index a screw requiring a multiple thread, the pawl is disengaged and the inner part of the spindle is turned whatever fractional part of a revolution may be required. For instance, if a double thread were being milled, the indexing movement would equal one-half revolution, whereas for a triple thread it would be necessary to index one-

third revolution, and so on. As a machine of this type is used for many other helical milling operations other than screw threads, the index ring is provided with forty-eight notches for accommodating other classes of work.

When it is necessary to mill helical grooves of exceptionally long lead, it might not always be practicable to drive the lead-screw from the work-spindle in the usual manner, because of the excessive stresses to which the change-gears would be subjected. One method of avoiding this difficulty in connection with lathe practice has been to drive the work-spindle from the lead-screw. The drive can be changed in this same way when using the thread milling machine shown in Fig. 1, by simply shifting clutches which, for work of the class mentioned, make the lead-screw the driver and the work-spindle the driven member. These machines are sometimes provided with what is known as a "backing-out attachment." This is simply an arrangement for gradually withdrawing the cutter at the end of a thread so that the thread groove will gradually taper from the full depth out to zero, instead of abruptly rising from the bottom to the top of the thread groove. When this attachment is in use the cutter withdraws while the work is making three turns. This method of finishing the end of a screw thread is desirable when screws are subject to severe shocks, as, for example, the screws of rock drills.

The style of milling cutter used on the Pratt & Whitney thread milling machine is shown in Fig. 3. This is a special form of cutter having staggered teeth. The teeth do not extend across the cutter, but are arranged to cut only on one side, each cutting edge being midway between the adjacent edges on the other side. One tooth is left full for the purpose of gaging. The cutter is made in this way so that the oil or cutting compound has free access to the cutting edges and the chips readily escape or are washed away by the lubricant. A special automatic grinder is used for sharpening these cutters. This grinder has three wheels, two of which are for grinding the angular sides; after the sides are finished, the third wheel is used for sharpening the points of the teeth.

Lees-Bradner Thread Milling Machine. — The thread milling machine shown in Fig. 4 is another example of the type which mills a screw thread by traversing a cutter along the work while the latter revolves but remains in the same lengthwise position. The change-gear mechanisms for controlling the lead of the thread to be milled, the speed of the work-spindle or the feeding movement, and the cutter speed are incorporated in the design of the headstock. All movable parts are driven from a single belt pulley at the rear. Motion is transmitted to the cut-

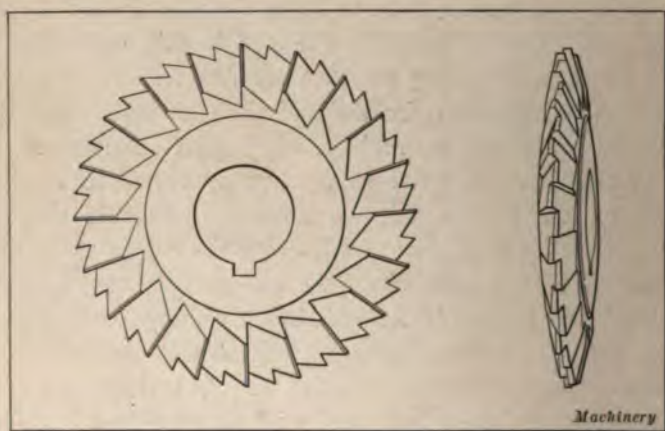

Fig. 3. Kind of Cutter used on Pratt & Whitney Thread Milling Machine

ter-spindle *A* by means of a splined shaft which extends along the rear side of the bed and is connected to the cutter-spindle through suitable gearing. The cutter-head is of cylindrical design and can be swiveled 180 degrees for aligning the cutter with a thread groove or any other helical groove. The angular position of the cutter-spindle is indicated by graduations and a vernier scale. The lateral position of the cutter is controlled by handwheel *B*. The depth of the cut is indicated by a micrometer dial and it may be regulated positively by an automatic adjustable stop which is used either when milling duplicate screw threads or multiple threads.

The traversing movement of the cutter carriage along the bed may be controlled automatically by stops *C* and *D* and also

by hand-lever *E*, with which the trip-rod *F* is connected. The machine is idle when clutch lever *E* is in the neutral position shown in the illustration. When this lever is shifted to the right, thus engaging the positive feed clutch, the carriage travels to the left until it engages stop-collar *C*, which is set in accordance with the length of thread to be milled. After the cutter is withdrawn from the work, the carriage may be rapidly re-

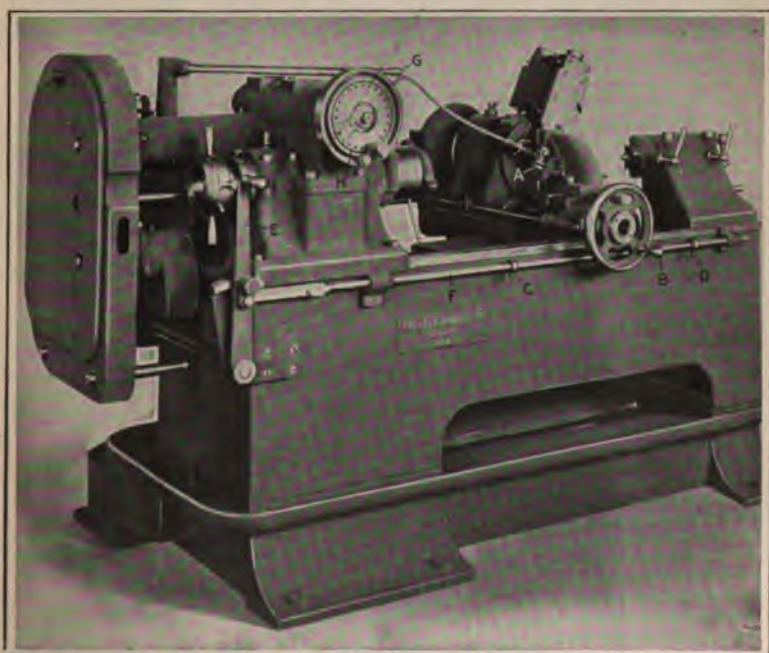

Fig. 4. Lees-Bradner Thread Milling Machine

turned to the starting position by throwing lever *E* to the left, which engages a friction clutch. The return movement of the carriage is arrested by collar *D*, which swings lever *E* to the neutral position again. The operating parts of the machine are started or stopped by lever *G*.

The work may be held between centers or in a collet chuck at the headstock end and on a center at the tailstock end, if this additional support is necessary. The collet chuck should

be used if possible. The work may be turned independently by means of the indexing mechanism at *H*, which is used when cutting multiple screw threads or for relocating the cutter with a previously milled thread groove.

When threads of fine pitch are to be milled, a multiple form of cutter is used, instead of a single cutter, in order to finish a thread complete in practically one revolution of the spindle. The detailed view, Fig. 5, shows a multiple cutter milling a thread on one section of a spindle. The steadyrest shown in

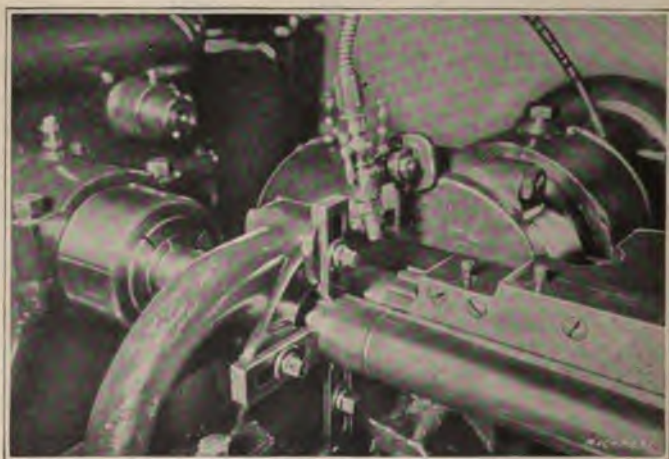

Fig. 5. Detail View of Lees-Bradner Machine milling Screw Thread with a Multiple Type of Cutter

this illustration and in Fig. 4 is used for supporting all flexible parts. While this machine is designed primarily for milling such parts as lead-screws, worms, etc., it may also be employed for milling either spiral or spur gears. It is manufactured by the Lees-Bradner Co., Cleveland, Ohio.

Moline Thread Milling Machine. — The machine shown in Fig. 6 differs from the designs previously described in that it has a traversing work-table and a cutter which revolves in one position when milling a thread. The work-table carries the headstock and tailstock spindles for holding the work between centers, and is traversed at the proper rate for generating a

thread of the required lead by means of change-gears, seen at the end of the machine, which connect the main or headstock spindle with the lead-screw. This machine is adapted for milling threads of coarse pitch or large worms. The cutter can be adjusted to the helix angle of the thread as well as laterally for feeding it in to the depth of the thread or away from the work.

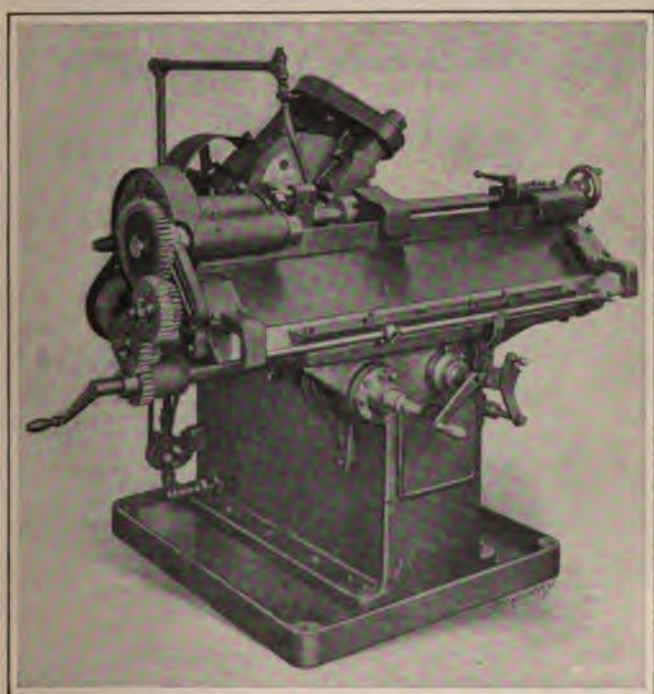

Fig. 6. Moline Thread Milling Machine

This machine has an indexing mechanism for use when cutting multiple threads. This device consists of an index plate attached to the driving gear of the main spindle and having suitable holes which are engaged by a plunger. The work may either be held between the centers, as shown in the illustration, or in a collet chuck or jaw chuck screwed onto the spindle. When parts are held between centers, a steadyrest block, provided with bushings, may be used for supporting the work.

This machine has a maximum swing of 8 inches and will hold parts 30 inches long between the centers. The spindle is hollow and a $3\frac{1}{2}$ -inch shaft may be passed through it. This machine is made by the Moline Tool Co., Moline, Ill.

Waltham Thread Milling Machine.—The thread milling machine illustrated in Fig. 7 is intended for small precision work. The cutter-slide of this machine is traversed along the bed by a lead-screw connecting with the work-spindle through change-gearing. The machine is driven from a constant-speed

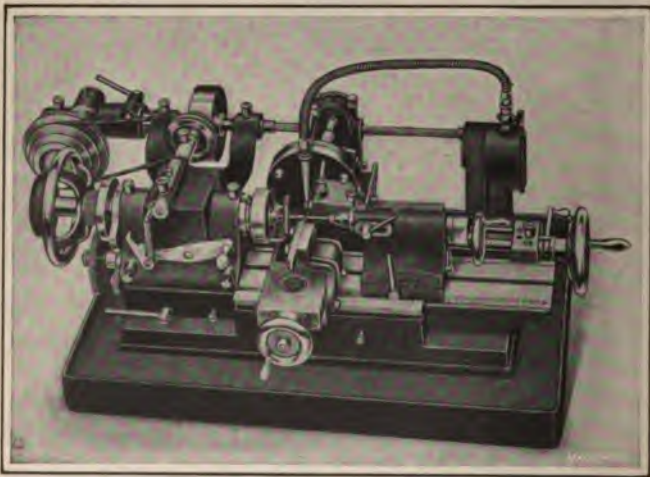

Fig. 7. Waltham Thread Milling Machine

shaft mounted in brackets on the rear side. This shaft drives the work-spindle through the cone-pulleys shown and worm-gearing. The four-step cone-pulleys are interchangeable and provide the necessary speed changes. The milling cutter spindle is set at the helix angle of the thread as shown by graduations on the circular base of the swiveling member. When a thread has been milled to the required length, the machine is stopped automatically by the disengagement of a clutch on the work-spindle. Oil or some cutting compound is supplied to the cutter by means of a pump driven from the constant-speed shaft at the rear of the machine. Tapering threads may be milled by using a taper

attachment which is similar in principle to the attachment found on engine lathes. This machine also has a compensating bar for obtaining slight variations in the lead of a screw thread to compensate for shrinkage in hardening, as when making thread gages or taps. A pointer attached to the swiveling bar extends through to a graduated index at the front of the machine and shows the amount of increased lead that can be obtained. The angular position of the compensating bar can be changed by means of two thumb-screws at the front of the

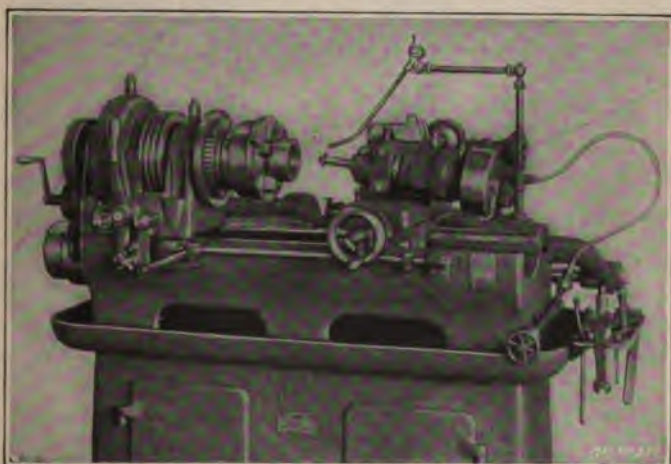

Fig. 8. Pratt & Whitney Internal Thread Milling Machine

machine. The right-hand bearing of the lead-screw is threaded, and this bearing can be rotated by a lever to change the location of the cutter carriage in relation to the thread groove. This fine longitudinal adjustment may be used for setting the cutter to match a thread groove that has previously been milled. This machine is made by the Waltham Machine Works, Waltham, Mass., and is intended for tool-rooms and experimental laboratories, as well as for universal use on work within its range.

Internal Thread Milling Machine of Single-cutter Type.— The Pratt & Whitney internal thread milling machine shown in Fig. 8 is adapted particularly for milling threads of moderate pitch in holes varying from $1\frac{1}{4}$ inch in diameter up to

about 6 inches. The work-spindle and cutter-spindle are both driven from a horizontal shaft at the rear carrying a three-step cone-pulley. The speed of the work-spindle is varied by means of a gear-box at the rear of the machine, eighteen speed changes being obtained for each of the three positions of the belt on the cone-pulley. The cutter-spindle is driven through gearing from the shaft referred to, and, in order to eliminate

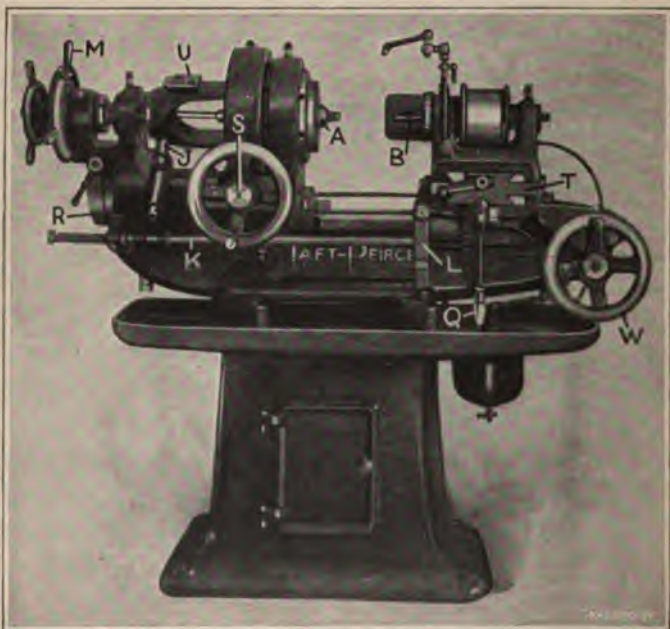

Fig. 9. Taft-Peirce Thread Milling Machine of Multiple-cutter Type

any tendency on the part of the cutter to chatter, owing to lost motion in the driving gears, use has been made of a fly-wheel which is mounted in bearings that are independent of the spindle. The cutter-spindle head is so constructed that the angular adjustment of the cutter for aligning it with the helical thread groove does not disturb the central relation between the cutter and the thread being milled. The lateral position of the cutter may be regulated by means of a microm-

eter dial and a positive adjustable stop. The latter enables the cutter to be withdrawn from the screw thread and returned for cutting a thread groove of the same depth. The spindle of this machine is provided with a notched index ring and a pawl which holds the inner and outer spindle sections together, as described in connection with the machine illustrated in Fig. 1. When cutting a multiple thread, the work is indexed by simply releasing the pawl and turning the inner spindle whatever fractional part of a revolution may be required.

Taft-Peirce Thread Milling Machine. — A thread milling machine of the multiple-cutter type which completes a thread in practically one revolution of the work is shown in Fig. 9. This machine is manufactured by the Taft-Peirce Mfg. Co., Woonsocket, R. I. The cutter-spindle and work-spindle are driven by separate belts leading from the same countershaft. The work is held in some form of chuck or fixture at *A*, and the cutter, which is partly enclosed by a guard for the protection of the operator, is located at *B*. When a thread is being milled the cutter is set transversely for milling the thread to the proper depth, and the work-spindle then advances a distance equal to the pitch or lead of the thread as it turns one revolution plus a slight amount of over-travel. The work is held either in a self-centering chuck or a special fixture which may be fitted to the counterbore *A*, Fig. 10, on the front end of the work-spindle. This spindle is of the open yoke design and is driven from a cone-pulley at the rear of the machine, from which motion is transmitted through bevel gears to worm-shaft *E* and a worm to a worm-wheel on the work-spindle. This drive is controlled by the engagement of a sliding clutch operated by a rod *F* extending through the hollow worm-shaft. On the front end of this rod there is a knob *S*, Fig. 9, used for engaging or disengaging the clutch. The teeth in the worm-wheel are not of the usual concave or curved form, but extend in a straight path diagonally across the face of the worm-wheel, so that the work-spindle will be free to move longitudinally when milling a thread. This longitudinal movement is derived from a master nut *D* and a lead-screw *C*, Fig. 10. The lead-screw is made in two

parts, and when assembled in the master nut there is a space between the two sections which provide a means for compensating for wear. The lead-screw and work-spindle rotate together and the master nut *D* and handwheel *M* are held stationary, when milling a thread, by lock-pin *N*, so that the work-spindle moves longitudinally. The pitch of the thread in the lead-screw and master nut must correspond with the pitch of the thread to be cut.

The cutter-spindle slide is mounted on an intermediate slide *T*, Fig. 9, which rests upon the lower slide. The upper cutter-

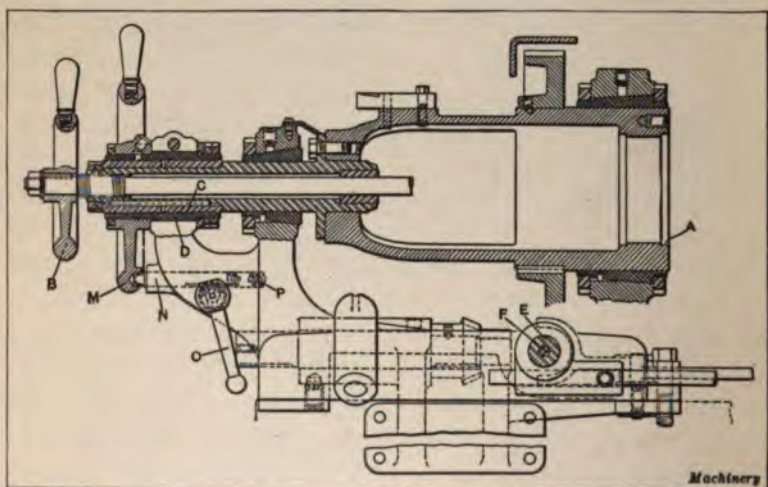

Fig. 10. Sectional View of Headstock of Machine shown in Fig. 9

slide is adjusted transversely by a screw. A positive stop is provided to insure returning the cutter-slide to the same position. The intermediate slide also has a transverse movement for withdrawing the cutter at the completion of a cut or for returning it to the working position. After the work-spindle completes one revolution, a cam *U* on the work-spindle engages a trip pin *J* and through a bell-crank mechanism operates the horizontal shaft *K* which releases the knock-off lever *L*. When this lever *L* is withdrawn, a spring throws the cutter-slide back so that the cutter is removed from the work; the work-spindle

and feed motion are also stopped at the same time. The cutter-slide and cutter are returned to the working position by pulling up lever *Q*. After the cutter-slide has advanced to the right location, the lever *L* drops into place and holds the slide until another thread has been milled.

The saddle which rests on the bed and carries the cutter-slide may be adjusted longitudinally along the bed by turning handwheel *W*, the shaft of which carries a pinion meshing with a rack. For most external thread milling operations this saddle is locked in position and is seldom adjusted, but for most internal work it is necessary to move the cutter-slide along the bed for withdrawing the cutter from the work so that the piece can be removed from the chuck or holding fixture. A stop is provided on the bed against which the saddle is located in the operating position in order to maintain the same relation between the position of the cutter and the face of the fixture or work. When the parts to be threaded are inserted through the opening in the work-spindle at the rear of the front bearing for internal thread milling, it is not necessary to move the saddle when a part is completed.

Parts $3\frac{1}{4}$ inches in diameter by 10 inches long may be held in a spring chuck, and if a regular lathe chuck is used, it is possible to hold work up to $4\frac{7}{8}$ inches in diameter by approximately 18 inches long. When a lathe chuck is applied to this machine it is fitted to the counterbore *A*, Fig. 10, at the front end of the work-spindle. Special chucks or fixtures for holding flanges, etc., may be as large as 18 inches in diameter, which represents the full swinging capacity of the machine. Pneumatically operated chucks are recommended for use in this machine, as it is possible to increase the production from 20 to 50 per cent as compared with hand-operated chucks. The handwheel shown at *B* is used for operating chucks of the spring or collet type.

This type of machine is especially designed for milling comparatively short internal or external threads located at or near the ends of parts. The length of thread which can be milled depends upon the pitch of the thread and the kind of material that is to be cut. Some examples of work milled on the Taft-

Peirce machine are shown in Fig. 11. The internal threading operation on the small brass parts shown at *A* was done at the rate of 90 pieces per hour; the thread in this case is $1\frac{3}{16}$ inch in diameter and 20 pitch. The internal threading operation on the part shown at *B* was done at the rate of 55 pieces per hour, the threads being $1\frac{3}{8}$ inch in diameter and 6 pitch. The brass part illustrated at *C* has a thread 2 inches in diameter and 14 pitch, and was milled at the rate of 60 per hour. The pressed aluminum piece shown at *D* has an external thread $1\frac{3}{8}$ inch in

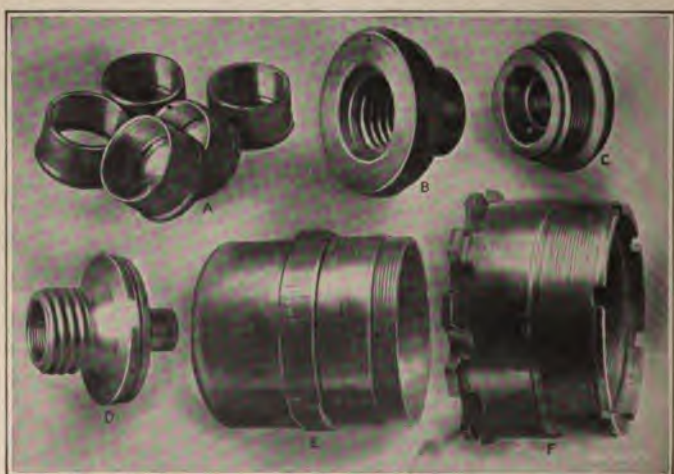

Fig. 11. Miscellaneous Examples of Thread Milling performed on Machine shown in Fig. 9

diameter and 6 pitch; the thread is the Whitworth form and these parts were milled at the rate of 70 per hour. The clutch housing shown at *E* has a 3-inch thread of 16 pitch, and 26 housings were milled per hour. The internal threading operation on the part shown at *F* was performed at the rate of 30 pieces per hour, the thread being $3\frac{1}{4}$ inches in diameter and 16 pitch; the external thread on this same part is $4\frac{1}{2}$ inches in diameter and 16 pitch, and was milled at the rate of 25 pieces per hour. The different rates of production referred to are not given as representing the maximum, but the output under normal conditions in regular manufacturing practice.

Lees-Bradner Multiple-cutter Type of Thread Milling Machine.—The Lees-Bradner special or “collet type” thread milling machine shown in Fig. 12 is the type having a multiple cutter and a lead-screw driven through change-gears selected with reference to the pitch of the thread to be milled. The work-spindle is driven through suitable gearing from a single

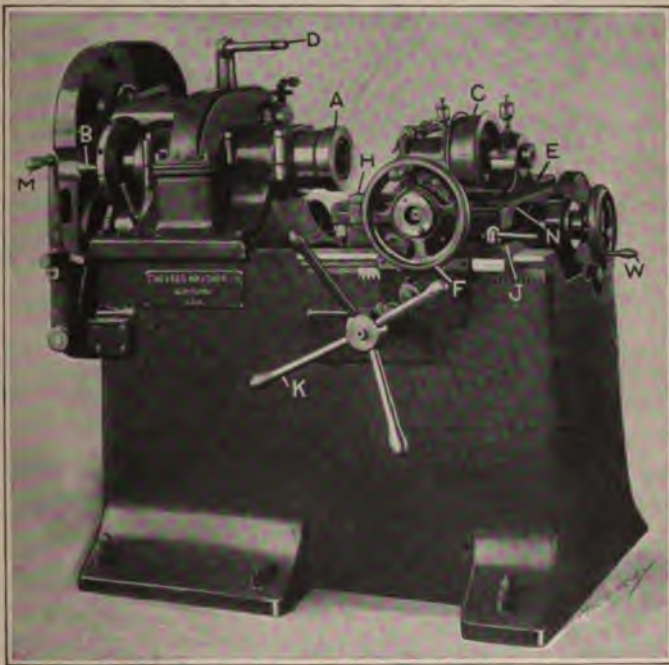

Fig. 12. Lees-Bradner Collet or Multiple-cutter Type of Thread Milling Machine

constant-speed belt pulley at the rear, and the cutter-spindle is revolved by a belt operating on pulley *C*. The rotation of the work-spindle as well as the feeding movement of the cutter-slide may be started or stopped by operating hand-lever *D*, which serves to engage or disengage a friction clutch.

The cutter-spindle is carried by a slide *E* (see also the sectional view, Fig. 13), which, in turn, is mounted on an intermediate slide *N*, supported by a bottom slide or main saddle

J, which rests upon the ways of the machine bed. The main saddle *J* may be adjusted along the bed by handwheel *K* for locating the cutter in the right lengthwise position relative to the work, and this saddle may be locked to the bed. The intermediate slide *N* connects with a short lead-screw *R*, Fig. 13. This lead-screw is driven through gearing by a splined shaft *S*, which is revolved by means of change-gears selected according to the pitch of thread to be milled. The upper slide which carries the cutter-spindle may be adjusted in a cross-wise direction by means of handwheel *F*, Fig. 12, to suit the diameter of the work and depth of thread to be milled. When

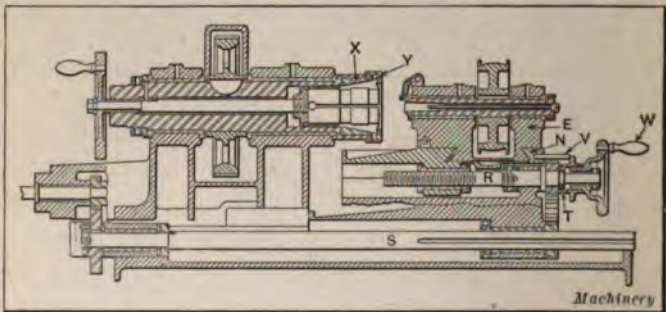

Fig. 13. Sectional View, showing Important Features of Machine illustrated in Fig. 12

the feed-lever *M* is pulled over to the place marked "feed" on the quadrant, the cutter-slide *N* operates, assuming that lever *D* is in the right position. When lever *M* is thrown in the opposite direction as far as it will go, the work-spindle may be revolved with a rapid reverse motion.

Motion is transmitted to the intermediate cutter-slide by the splined shaft and lead-screw referred to, in order to avoid a reversal of the rotating parts each time a thread is milled and the resulting loss of time which would occur while waiting for any backlash or lost motion in the transmission to be taken up. When milling a thread, the intermediate and upper slides with the cutter-spindle are traversed along the bottom slide or main saddle *J* a distance equal to the pitch of the thread plus a slight amount of over-travel. This traversing movement is away from

the chuck for internal milling and toward the chuck for some external milling operations. If ten threads to the inch were being milled, the traversing movement of the intermediate slide on the bottom slide would equal approximately $\frac{1}{10}$ inch for each thread milling operation. As the intermediate slide has a total travel on the main saddle of about five inches, obviously threads could be milled on about fifty pieces before it would be necessary to return the intermediate slide to the starting point. The number of parts that could be milled before it becomes necessary to reverse the lead-screw and return the slide depends upon the pitch of the thread. When the intermediate slide has reached the limit of its travel, the clutch at *T*, Fig. 13, through which the lead-screw *R* is driven, is disengaged by pin *V*. The operator then revolves the lead-screw in the opposite direction by means of handwheel *W*. The quick-return lever *M*, Fig. 12, may also be used to control the return of the slide to the other end of its travel preparatory to milling another lot of parts. Any movement of the main slide on the bed which may be necessary for inserting the work in the chuck or removing it does not necessitate disengaging the lead-screw clutch or reversing its driving mechanism.

The crosswise position of the cutter is indicated by an adjustable micrometer dial reading to thousandths of an inch which is located just back of handwheel *F*. This dial is set at the zero position when the cutter just touches the part to be milled. The micrometer dial is then locked in position and the handwheel turned far enough to move cutter-slide *E* an amount depending upon the depth of the thread to be milled. When the cutter has been fed in to the right depth, a stop on the handwheel should be adjusted so that it is in contact with stop *H*. The latter may be adjusted by means of a binder screw operating in cutter-slide *E*, so that stop *H* will intercept the stop on the handwheel *F* when slide *E* is in position for milling a thread. The engagement between the two stops referred to is such that stop *H* moves far enough during one revolution of handwheel *F* to clear the stop on the wheel. When the cutter-slide is returned to the milling or working position,

stop *H* will again engage the handwheel stop automatically and locate the cutter at whatever depth it was previously set to.

The collet chuck *A* in which the work is held is opened or closed by handwheel *B*. This collet chuck (see sectional view, Fig. 13) is an ingenious design so arranged that the collet is positively actuated both when opening and closing. This collet is made of machine steel and the jaws are casehardened, but the flexible part is left unhardened. When the collet is drawn back against the tapering seat *X* in the spindle, it grips the

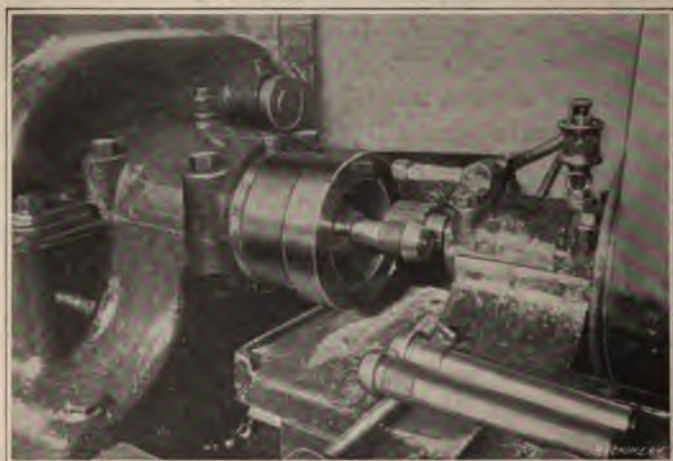

Fig. 14. External Thread Milling on Multiple-cutter Type of Machine

work, and when moved in the opposite direction one side of a V-shaped groove on the outer end engages another tapering seat in ring *Y*, thus positively forcing the collet jaws outward. The amount of this expansion is regulated by the distance the ring *Y* is screwed on or off the end of the spindle. With this arrangement it is unnecessary to have a spring temper in the flexible part back of the jaws. The detailed view, Fig. 14, shows one of these machines milling external threads on shell fuses.

Thomson Thread Milling Machine.—The multiple-cutter type of thread milling machine shown in Fig. 15 is designed for

milling threads on such parts as rifle barrels, rifle receivers, bronze primers, fuse bodies, the nose pieces for the smaller shells, automobile parts, watch cases, or whenever a short thread of a pitch not greater than 12 threads per inch (in steel) is required. When a thread is being milled, the work-spindle of the machine is advanced as it revolves by a short lead-screw which is mounted

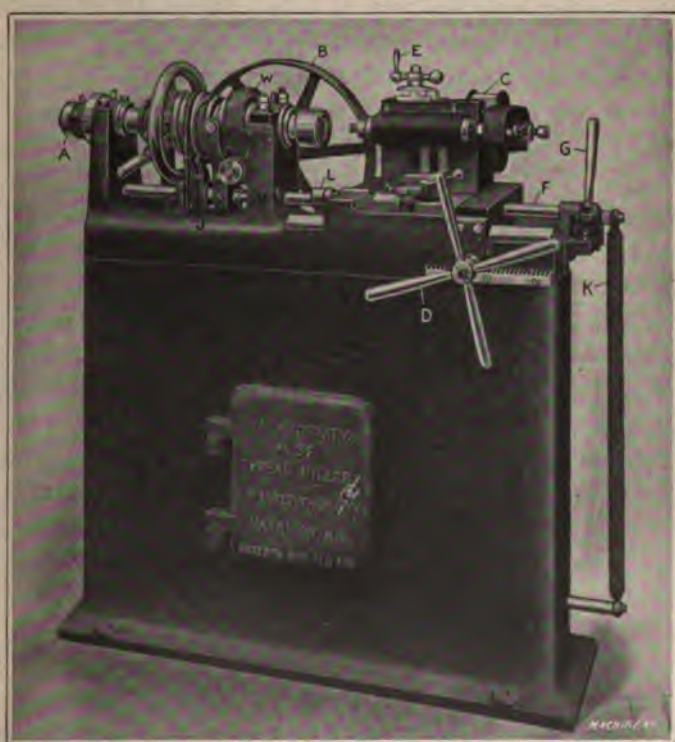

Fig. 15. Thomson Thread Milling Machine of Multiple-cutter Type

on the spindle and engages an adjustable nut *A*. The work-spindle and the cutter-spindle each have a separate driving belt. The large pulley *B* back of the headstock is for driving the work-spindle and transmits motion to it through worm-gearing. The belt pulley *C* drives the cutter-spindle by means of a silent chain. The cutter-spindle is carried by a vertical sliding head, which, in turn, is mounted on a carriage that can be moved along the

horizontal ways of the machine bed by the handwheel *D*. The cutter is adjusted for the right depth of cut by means of handle *E* attached to the adjusting screw and equipped with a micrometer dial reading to thousandths of an inch. After the cutter is once set in the right position, it is advanced and withdrawn from the work by the action of a cam on the horizontal shaft *F*, which is turned by hand-lever *G*. One movement of this lever moves the cutter up to the cutting position and, at the same time, engages a clutch with the worm-wheel *W*, which revolves loosely on the work-spindle except when a thread is actually being milled. As the work-spindle revolves, it also advances at a rate depending upon the pitch of the lead-screw thread, which must correspond to the pitch of the thread to be milled. Attached to a drum on the work-spindle there is a wire cable *H*, which connects with a spring drum located inside of the machine base. This cable is slowly wound upon the work-spindle drum as the spindle revolves, until a sleeve attached to cable *H* comes into contact with trip lever *J*. When this lever is raised, shaft *F* is released and turned backward by the tension spring *K*, thus withdrawing the cutter from the work and stopping the spindle. The mechanism is so arranged that this tripping action occurs after the work has made a little over one revolution and the thread is completed. When milling internal threads, the cutter-slide is withdrawn by means of handwheel *D* after each operation, in order to remove the work from the chuck. An adjustable stop-rod *L* on the cutter-slide comes into engagement with stop *M* and serves to relocate the cutter after it has been withdrawn for removing work having internal threads. The cutter-slide is locked to the machine bed when a thread is being milled. This machine is made by the T. C. M. Mfg. Co., Harrison, N. J.

Smalley-General Thread Milling Machine.—The thread milling machine illustrated in Fig. 16 is arranged especially for shell work, although it can be equipped for general thread milling by removing the special shell-holding chuck and attaching some other form of chuck. This machine (manufactured by the Smalley-General Co., Bay City, Mich.) has a multiple cutter

for finishing a thread in practically one revolution, and the particular machine illustrated is equipped for milling threads in the bases of 9.2-inch high-explosive shells. The chuck for holding these shells is pneumatically operated, and by the use of liners the adapter and plugs for these shells may also be threaded in this machine. The cutter-spindle is mounted on a carriage which is traversed along the bed by a gear-driven lead-screw when milling a thread. The carriage can also be traversed by turning the large handwheel seen at the front of the machine.

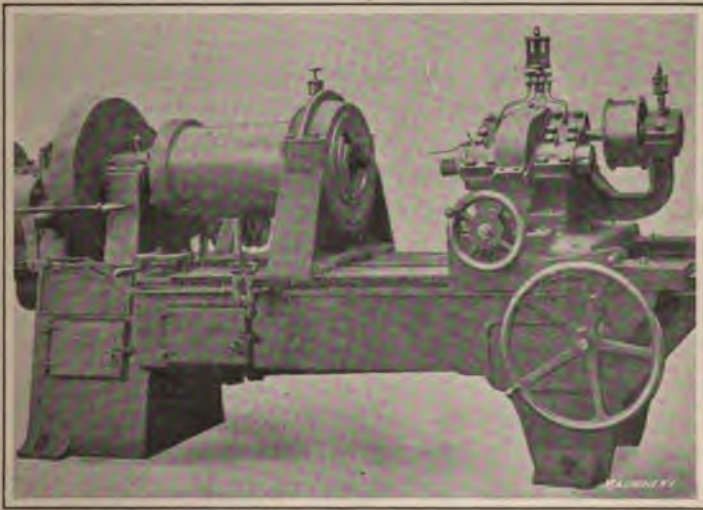

Fig. 16. Smalley-General Thread Milling Machine equipped with a Special Chuck for Shell Work

The cutter-spindle and the work-spindle are driven independently by separate belts. The drive to the spindle is so arranged that the comparatively slow speed required for thread milling can be increased sufficiently for turning operations. In order to perform operations of this kind where a surface or shoulder must be absolutely true with a milled thread, the machine is equipped with a turning tool. This tool is located near the milling cutter and is used on the 9.2-inch shells referred to for finishing a recess at the end of the shell.

The tool is so located that the thread milling cutter can be

used without moving the turning tool, or the latter can be used without removing the cutter. The normal feed for thread milling, which is about six inches per minute, is increased to twenty-five feet per minute for turning. The single-belt pulley which drives the main spindle transmits motion to it through a worm-gear and spur-gear. The high speed for turning is obtained by driving direct through the spur-gearing, and the speed is reduced for thread milling by driving through the worm-gearing. This change of speed is obtained by shifting a lever located on the main head, which operates a clutch. This lever is held in either the high-speed, low-speed, or neutral position by a notched quadrant. The gear on the main spindle which drives the train of change-gears is free to slide in or out of mesh for disengaging the lead-screw drive.

One of the special features of this machine is the method of engaging the lead-screw nut with the cutter-slide or carriage. On the lead-screw there is a nut which is attached rigidly to a wedge bar which moves along with the nut whenever the lead-screw is in motion. On the bottom of the cutter-slide there are two wedge blocks. One block is fixed and the other is controlled by means of a lever which is located just above and back of the large handwheel for traversing the cutter-slide or carriage along the machine bed. These two wedge blocks engage grooves on each side of the wedge bar for transmitting motion from the lead-screw to the cutter-slide. The advantage claimed for this arrangement is that the operator does not have to wait for the lead-screw to engage a split nut. By means of an extra idler gear, which may be inserted in the train of change-gears, the lead-screw is made to rotate in the right direction for milling either right- or left-hand threads. The cutter-spindle of the particular machine illustrated is driven through herringbone gears from the belt-pulley shaft. Machines used for comparatively light work have the belt pulley mounted directly on the cutter-spindle.

To illustrate the method of using this machine, it will be assumed that an internal thread is to be milled and a shoulder faced off true with the thread. After the work is chucked, the

cutter-slide is traversed along the bed by the large handwheel until the "hob" or thread milling cutter is properly located in a lengthwise direction, the feed-lever for engaging the lead-screw being released. The cutter is usually located by means of a depth gage or by moving it in against a shoulder which serves as a locating point. The main spindle should be revolving at the slow speed of five or six inches per minute. The cutter-spindle is also revolving, and after the cutter-slide is connected to the lead-screw by means of the feed-lever, the cutter is immediately fed into the work. The proper depth of cut is indicated by a micrometer dial on the cross-feed screw and the work should revolve until the cutter passes the point at which it started to cut to the full depth of the thread. When the thread is completed the cutter is withdrawn and the drive to the lead-screw is disengaged by means of a control lever provided for this purpose. The main spindle is now revolved at the higher speed for turning, and the turning tool is used for facing the shoulder true.

A larger machine designed along the same general lines as the one illustrated in Fig. 16 has been used for milling threads having a pitch of $\frac{1}{4}$ inch, a length of $4\frac{7}{8}$ inches, and a diameter of $9\frac{1}{2}$ inches. Threads of this size were milled in nickel steel armor-piercing shells.

Reed-Prentice Thread Milling Machine. — Fig. 17 shows a single-purpose thread milling machine designed especially for milling external threads on rifle barrels and the internal threads in rifle receivers. The machine, as illustrated, is arranged for the thread-milling operation on the receivers. The special work-holding fixture is designed to hold each receiver in the same position so that the thread will start at a predetermined point, thus making all the receivers interchangeable. When the machine is used for milling the external threads on rifle barrels, the receiver fixture shown in the illustration is removed and a special collet chuck is used which grips the barrel at the breech end close to the part that is to be threaded. The barrel extends through the hollow spindle of the machine and provision is made for accurately locating each barrel so that the threads

start at a fixed point and are interchangeable with the receivers. The muzzle end of the barrel is supported by a special cam-action closer which holds the muzzle end concentric with the breech end. When a thread is being milled, the carriage upon which the cutter-spindle is mounted is traversed along the bed by a lead-screw, which is driven through change-gears. This lead-screw is engaged by a split nut, the arrangement being

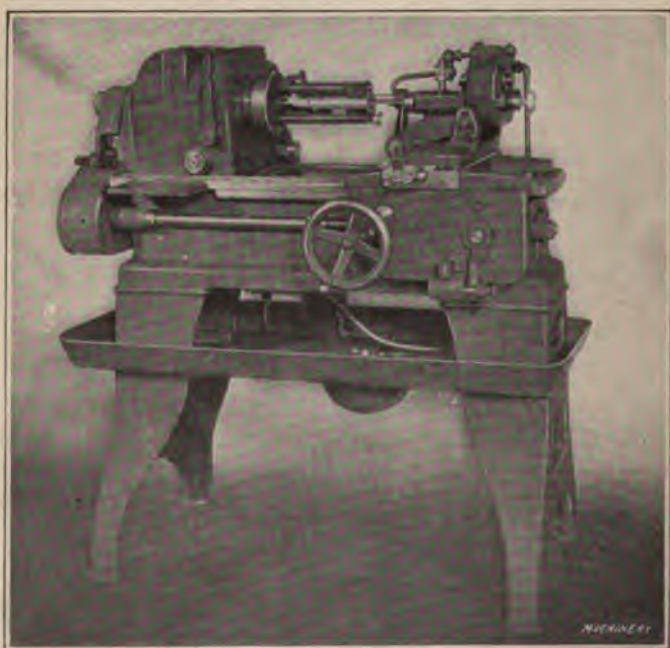

Fig. 17. Reed-Prentice Thread Milling Machine arranged for Internal Work

similar to an engine lathe. The bearing or bracket carrying the cutter-spindle is pivoted at one end, so that the cutters can be set in line with the angle of the thread, an adjustment of 5 degrees each side of the perpendicular being provided for. This machine is made by the Reed-Prentice Co., Worcester, Mass.

Bilton Worm Milling Machine. — A machine designed especially for milling small worms or similar parts is shown in Fig. 18. This machine is semi-automatic in its operation, the machine

stopping automatically after the worm thread is milled. The work is held in a collet chuck *A* (see detailed view, Fig. 19) and is additionally supported by a center *B* which may be either male or female. The spindle to which the chuck is attached is provided with a lead-screw or master worm *C* which is a duplicate as to lead or pitch of the thread to be milled. This lead-screw is revolved when milling a thread, through worm-gearing which connects by means of a telescopic shaft and universal

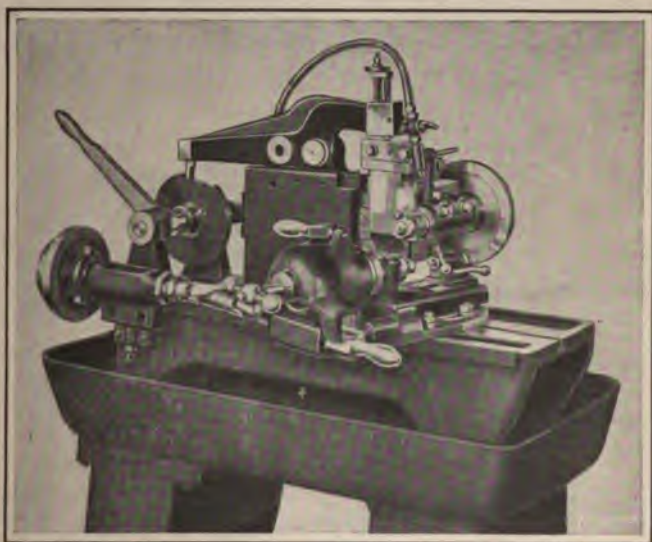

Fig. 18. Bilton Semi-automatic Worm Milling Machine

joint with a belt pulley seen at the left of the machine in Fig. 18. The cutter-spindle is carried by a slide which is moved downward for locating the cutter in the proper position by the hand-lever which is also seen at the left of the illustration. The required movement is imparted to the cutter-spindle slide by a cam on the hand-lever shaft which operates a lever that extends forward to the cutter-slide. The work-holding fixture illustrated in Fig. 19 is set to the helix angle of the thread as indicated by graduations on the base at *D*. When a thread has been milled to the required length, the trip dog *E* comes into engagement with the adjustable stop *F* which releases

lever *G* and allows the worm to drop out of mesh with the worm-wheel. The lead-screw and work-spindle are then returned to the starting point by means of handle *H*. This machine may be used for milling single, double, triple, and quadruple threads. The spindle is indexed for milling multiple threads with a single cutter, by means of index plate *J* which has holes engaged by a plunger or pin connecting with the operating lever *K*. For milling some double threads, a duplex cutter is used, so that both thread grooves are milled simultaneously and indexing is

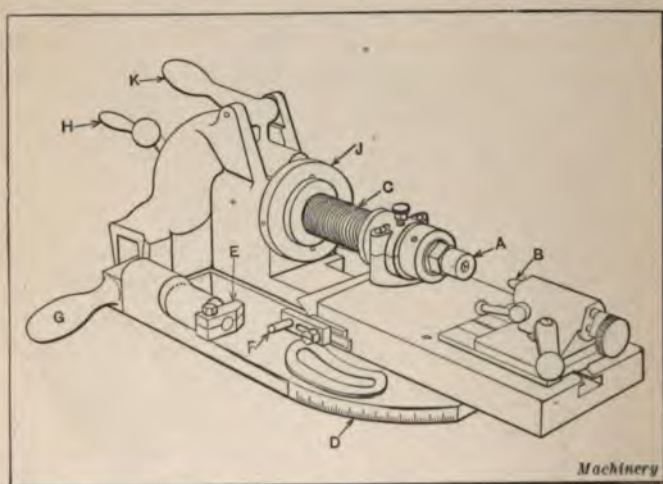

Fig. 19. Detail View, showing Lead-controlling, Indexing and Automatic Trip Mechanism of Machine illustrated in Fig. 18

unnecessary. This machine has a capacity for work $1\frac{1}{2}$ inch in diameter and $1\frac{1}{2}$ inch long, but it has been used more extensively for milling the small worms required in phonographs, auto-horns, organs, etc., which usually vary from about $\frac{1}{4}$ to $\frac{3}{8}$ inch in diameter.

Thread Milling on Standard Milling Machines. — Thread milling is frequently done on machines designed for general milling operations, such as the plain and universal milling machines of the column-and-knee type. There are two general methods of milling threads on ordinary milling machines. In the first place, the screw thread may be generated by using the

spiral or dividing head the same as when performing any helical or spiral milling operation. The spiral head is geared to the lead-screw of the machine for traversing the table and work a distance per revolution corresponding to the lead or pitch, and the cutter is held and driven by some attachment such as a vertical spindle, universal or spiral milling attachment, the alignment of the cutter with the thread groove being obtained either by swiveling the work-table or by adjusting the cutter driving attachment. While this method is commonly employed for a variety of helical or spiral milling operations, its application to thread milling is largely confined to the milling of worms or relatively short screws of coarse pitch, especially when such work is not done on an extensive scale.

The second general method of milling threads on ordinary milling machines is by equipping the machine with a special attachment designed for this work exclusively. These attachments are usually designed for milling threads on duplicate parts in connection with manufacturing, and they are arranged to hold the work and rotate it along a helical path while a cutter held either directly in the machine spindle or on an ordinary arbor mills the thread groove. The simplest form of attachment consists principally of a base or frame which carries a spindle and a lead-screw connecting either with a hand crank or some combination of gearing for imparting a rotary motion to the spindle and work.

A fixture intended for milling threads of fine pitch, especially in materials that are easily cut, may have a hand crank attached directly to the end of the work-spindle. With this arrangement, as the crank is turned, the lead-screw which passes through a nut attached to one of the fixture bearings causes the work to advance at the proper rate for milling a thread. The lead-screw is a duplicate of the thread required, as far as its lead or pitch is concerned. While such a fixture may be used for the lighter classes of work, in general it is preferable to transmit motion to the work-spindle through worm-gearing. The worm-wheel may be carried by the work-spindle which is splined to permit end-wise movement through the worm-wheel, whereas the hand

crank is mounted on the end of the worm-shaft. Some of these hand-operated thread milling attachments are provided with indexing plates for milling multiple threads. Fixtures of the general type referred to may be used in conjunction with a single cutter, or a multiple cutter may be employed for finishing a thread in one revolution of the work. If a multiple cutter is used, it is particularly desirable to have the work-spindle rotated through worm-gearing in order to obtain a more powerful turning movement.

Hand-operated Thread Milling Fixtures. — The simple form of thread milling fixture shown in Fig. 20 is intended for use on

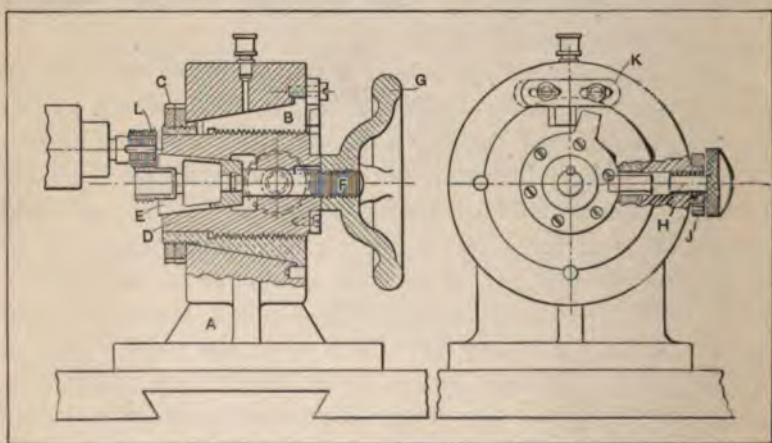

Fig. 20. Hand-operated Type of Thread Milling Fixture

an ordinary column-and-knee type milling machine. A multiple-cutter *L* is used for milling the thread and the work is held in a spring chuck or collet *E* which is opened or closed by turning handwheel *G*. The threaded part *D* serves as a lead-screw and passes through a tapering split bushing *B* which is held in position and adjusted by nuts *C*. The plunger *H* prevents the lead-screw from rotating when tightening or loosening the chuck. After the part to be milled is fastened in the chuck, plunger *H* is withdrawn and is held in the outward position by a small pin at *J*. The cutter is next fed in to the correct depth as determined by suitable stops and then the lead-screw *D* and work

are advanced by turning handwheel *G* through one revolution. This turning movement is controlled by a sliding stop *K* which has elongated holes that permit it to move from one side of the vertical center line to the other, so that the lead-screw can make one complete turn. After a thread is milled, the cutter is withdrawn and the spindle rotated back to its starting position. The chuck is then loosened by handwheel *G* after engaging the locking plunger *H*. This attachment is intended for milling fine threads which are easily cut.

The hand-operated thread milling attachment illustrated in Fig. 21 is equipped with worm-gearing for revolving the work-

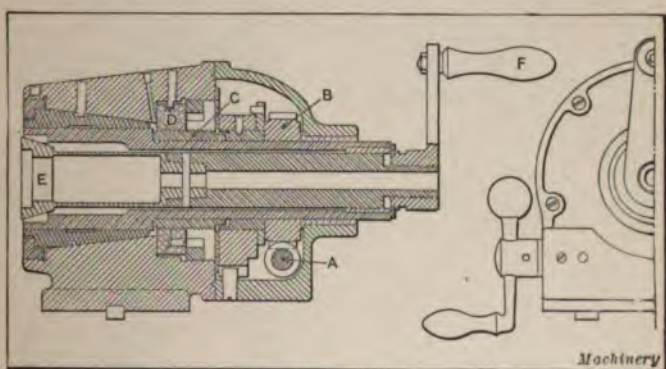

Fig. 21. Hand-operated Thread Milling Attachment having a Worm-gear Drive

spindle. The worm-wheel shaft *A* carries a crank at its outer end which is revolved to impart a feeding movement to the work. The worm-wheel on shaft *A* meshes with worm-wheel *B* which revolves the work-spindle. A threaded sleeve *C* attached to the work-spindle passes through the nuts *D* and serves as a lead-screw. The parts to be threaded are held in the collet chuck *E* which is opened or closed by turning crank *F*. This crank is also used to return the work-spindle to the starting position after a thread is milled. This attachment is used in conjunction with a multiple cutter so that the thread is finished in practically one revolution. It is manufactured by the Hall Gas Engine Co., Inc., Bridesburg, Philadelphia, Pa.

Thread Milling Attachments for Engine Lathes. — Engine lathes equipped with special attachments have been used to some extent for cutting threads by the milling process especially in connection with shell work. The special mechanism for converting a lathe into a thread milling machine usually consists of an auxiliary slide which is mounted on the carriage and is arranged to carry the revolving cutter-spindle and, in addition, some form of drive for reducing the speed of the work-spindle

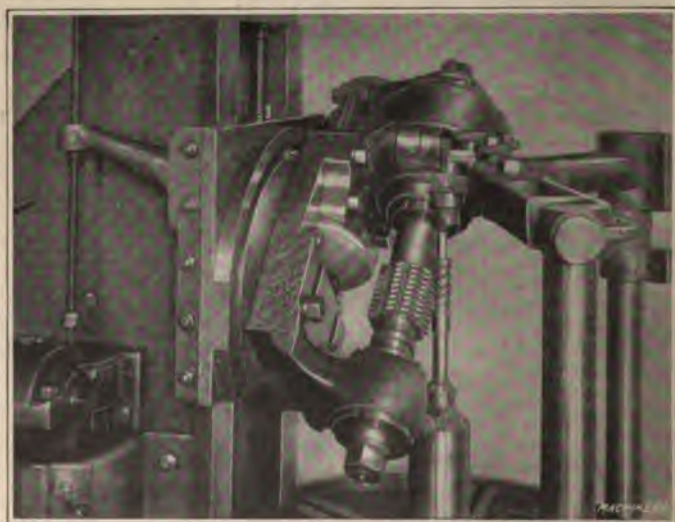

Fig. 22. Milling the Threads of a Multiple-threaded Screw by Means of a Hob and a Regular Gear-hobbing Machine

so that the surface speed of the thread being milled will be only a few inches per minute.

Hobbing Method of Thread Milling. — A hob is sometimes used in conjunction with a gear-hobbing machine for milling multiple screw threads. A hob used for this purpose has teeth which lie along a helical path, like a hob intended for cutting spur or helical gears, and it must be geared to revolve with the work at a definite speed ratio, the same as when hobbing a gear. The hobbing method is particularly efficient for cutting worms having several threads, because the hob finishes the different

threads simultaneously. A hob having teeth of special form must be used for milling worms or other screw threads in order to generate threads having sides which are, at least, approximately straight. Fig. 22 shows a Farwell gear-hobbing machine milling a five-threaded worm. A single-threaded hob is used and the threads are cut much more rapidly than when an ordi-

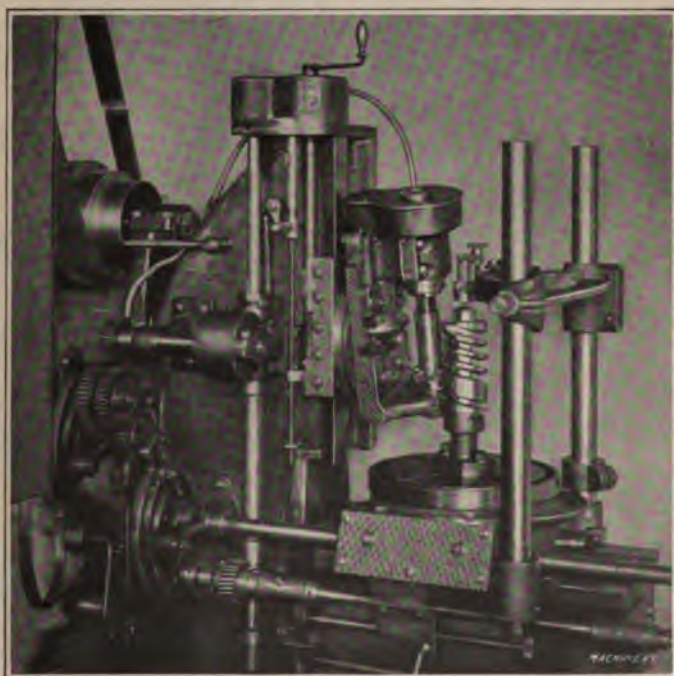

Fig. 23. Milling a Double Thread on a Farwell Gear-hobbing Machine equipped with a Single Milling Cutter

nary milling cutter is employed. The sides of the threads are not exactly straight, but the curvature is slight. Multiple-threaded worms having four threads or more may often be milled to advantage with a single-threaded hob by the general method illustrated in Fig. 22, but if the worm has only a single thread or a double thread, it should preferably be milled by using a single milling cutter as illustrated in Fig. 23, instead of employing a hob. When a single cutter is used on this machine,

the work-table of the machine is geared to the down feed so that a screw thread of the required lead will be milled, but without reference to the speed of the cutter which may be regulated to suit the thread milling operation. When a screw thread is milled in this way, the gear-hobbing machine is practically a thread milling machine, so far as the principle of its operation is concerned.

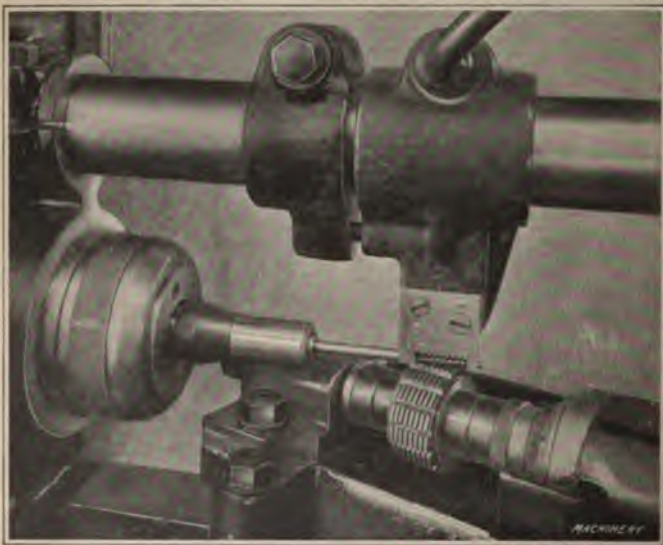

Fig. 24. Barber-Colman Gear-hobbing Machine milling a Worm Thread on the End of a Slender Spindle

An unusual and interesting application of a gear-hobbing machine to thread milling is illustrated in Fig. 24, which shows a No. 3 Barber-Colman machine cutting a worm thread on the end of a rather long and slender spindle. Owing to the flexibility of this spindle, a special form of work support was required. This consists of a plate supported by the overhanging arm and having two bearing surfaces which engage the screw thread at the ends, as the illustration shows.

CHAPTER XII

THREAD ROLLING

THE rolling process of forming screw threads may be defined as an impression or displacement method, since the thread grooves are not cut by an edged tool but are formed by means of a die or roll having threads or ridges which are forced into the metal and, by displacing it, produce a thread corresponding to the required shape and pitch. The plain blanks upon which threads are to be rolled are somewhat smaller in diameter than the finished thread, because the rolling process displaces a certain amount of metal which is forced up above the original surface of the blank, thus producing a screw thread which is larger in diameter than the original blank. The increase in diameter is approximately equal to the depth of one thread. No material whatever is removed by the rolling process, the metal from the depression formed by the die simply being forced up on either side.

Screw threads may be rolled (1) by using a circular disk or roll having a threaded periphery or (2) by rolling the blank between dies which may be either flat or circular in form. A circular roll is employed when screw threads are rolled on automatic screw machines or turret lathes, and the dies referred to are used when thread rolling is done by machines designed exclusively for this work. Thread rolling is done in automatic screw machines when a thread is required behind a shoulder or other intervening part, which makes it impossible to cut the thread by using a regular thread-cutting die. The advantage of rolling the thread in such cases is that a second operation is avoided. The important commercial application of the thread-rolling process is found in the shops and factories using the machines designed especially for this work. These machines are extensively employed in certain lines of manufacture for

threading such parts as bolts, screws, studs, rods, etc., especially where such threaded parts are required in large quantities. Screw threads that are within the range of the rolling process may be produced more rapidly by this method than in any other way, which accounts for the use of thread-rolling machines in connection with bolt and screw manufacture and wherever thousands of duplicate threaded parts are required. After describing the method of forming a thread by rolling a cylindrical

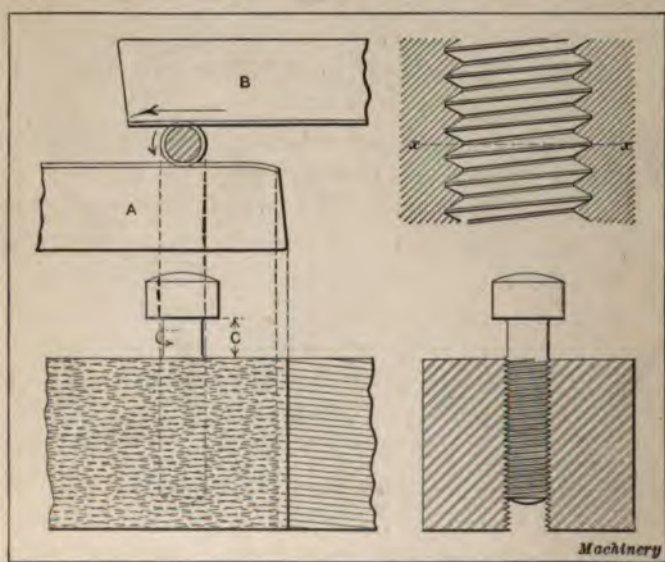

Fig. 1. Diagram illustrating how Screw Thread is rolled between Flat Dies

blank between flat dies, some of the different designs of thread-rolling machines and their method of operation will be considered.

Thread Rolling between Flat Dies. — Most of the machines designed exclusively for rolling screw threads are equipped with flat dies. There are two of these flat dies on a machine, as shown by the diagram, Fig. 1, which illustrates the general principle of the flat-die method of rolling threads. One die *A* is stationary and the other die *B* has a reciprocating movement. The face of each die has parallel grooves and ridges of practically the same cross-sectional shape as the thread to be rolled,

and are spaced to correspond with the required pitch. These ridges, which represent a development of the thread the dies are intended to roll, incline at an angle equal to the helix angle of the thread, so that, as the screw blank rolls between the two dies, a screw thread of the same pitch and helix angle is reproduced on it. The thread is formed in one passage of the bolt, rod, or other part to be threaded, the work being inserted at one end so that it simply rolls between the die faces until it is ejected at the other end. When the thread is not required along

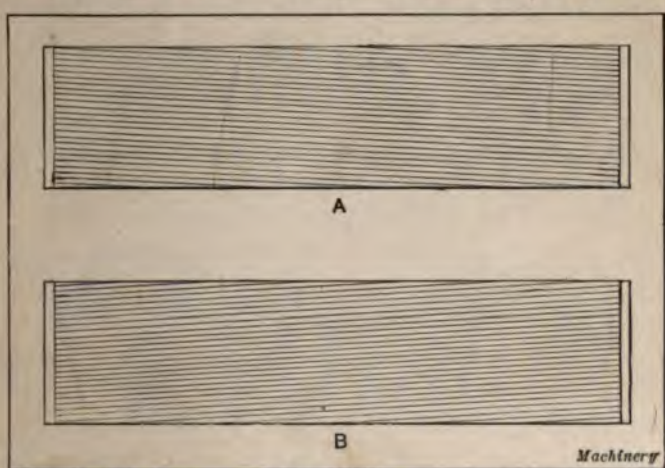

Fig. 2. (A) Die for Rolling Right-hand Threads. (B) Die for Rolling Left-hand Threads

the entire body of the bolt or screw, the work is started between the dies with the head a distance C above the top edges of the dies. The ridges on both dies incline in the same direction when viewed from the rolling sides or faces, but when the dies are in the thread-rolling machine, the ridges incline in the opposite direction and are, therefore, in alignment with the thread groove on the work at the two lines of contact. The face of a die for rolling a right-hand thread is shown at A in Fig. 2. The die shown at B is intended for a left-hand thread and, for that reason, the ridges incline in the opposite direction. So far as the inclination of the ridges is concerned, each of these dies is a duplicate of its mating die, as seen from the face side.

Relative Positions of Dies and Work. — The relation between the position of the dies and a screw thread being rolled is such that the top of the thread-shaped ridge of one die, at the point of contact with the screw thread, is directly opposite the bottom of the thread groove in the other die, at the point of contact, as indicated by the line $x-x$ of the enlarged sectional view, Fig. 1. This relation between the dies and the screw thread must be maintained throughout the thread-rolling operation, and it is essential to start the work between the dies when the movable die is in the right position. If the blank to be threaded is started at exactly the right time, the groove rolled into it by one die will engage or match with the ridges on the other die when the blank has turned a half revolution; therefore, since the two dies engage the screw thread on opposite sides and as one-half turn of the screw corresponds to one-half of the pitch, the ridges on one die must be one-half the pitch above or below corresponding ridges on the other die in a plane intersecting the axis of the screw thread being rolled.

In order to form the thread gradually, the two dies may not be set exactly parallel, but a little farther apart at the end where the rolling operation begins, so that, as the screw blank moves from the starting end through the dies, the thread is formed by a progressive rolling action. This method of setting dies is sometimes reversed, the dies being set a little closer together at the starting end. A full thread is then formed more rapidly at the beginning of the rolling operation. The object is to form the thread as quickly as possible so that there will be comparatively little pressure between the work and the die during the remainder of the stroke, in order to obtain a planishing effect and a smooth finish. There is a difference of opinion among the users and manufacturers of thread-rolling machines regarding the relative merits of these two methods of adjusting the dies. In any case, the adjustment from a parallel position is very slight.

Thread-rolling machines are equipped with some form of mechanism which insures starting the screw blank at the right time and also square with the sides of the dies. These machines

differ in regard to the position of the dies and the arrangement of the mechanisms which operate the moving die, the blank starting device, and other parts. Machines of this general class also vary in that some have automatic blank-feeding mechanisms, whereas others of simpler construction require the constant attention of an operator for feeding each blank between the dies by hand.

Diameter of Blank before Thread is Rolled. — The diameter of the screw blank or cylindrical part upon which a thread is to be rolled should be less than the required screw diameter by an amount that will just compensate for the metal that is displaced and raised above the original surface by the rolling process. If the screw blank is too large before rolling, there will be an excessive amount of metal and the screw will be larger than the standard size. On the contrary, if the blank is too small, either an incomplete thread will be formed or, if the dies are adjusted to roll a full thread, the diameter will be smaller than standard. While the blank diameter can be determined mathematically, it may be necessary to make slight changes in the calculated size in order to secure a well-formed thread. If the diameter is first calculated by using a rule or formula which is known to be at least approximately correct, the results should be verified by actual trial, if possible. The importance of determining accurately what blank diameter is required to form a full or complete thread depends somewhat upon the class or quality of the threaded work. For instance, in some plants where screw threads are rolled on ordinary bolts, etc., it is the practice to use blanks which are slightly smaller than the pitch diameter of the screw thread, and in many cases the threaded ends of the screws or bolts are a little smaller than the standard diameter, so that nuts tapped with standard taps will screw on easily. A full thread may be formed when using a blank that is less than the pitch diameter, but if this is done, the screw will be slightly under size. When completely formed screw threads of standard diameter are required, the blanks must be a little larger than those used on the less accurate classes of work.

Aside from the question of accuracy, the blank diameter is

affected to some extent by the nature of the material of which the screw blanks are made; that is, whether it is hard and offers considerable resistance to displacement, or is soft and easily formed by the threading roll. For instance, threads may be rolled in either brass or steel, but the action of brass is different from that of steel. The condition of the surface of a steel blank may also affect the diameter. When a thread is rolled on drawn stock, there is little, if any, compression of the metal as it is displaced to form a thread, because the surface is already quite dense as the result of the cold-drawing operation. If this dense outer surface, however, is removed by a cutting tool, the metal will then be subject to slight compression as it is displaced; consequently, a larger blank diameter is required for a turned piece than for one which was drawn to size. Brass blanks for screws of a given size should be a little larger than those made of steel for the same reason; that is, because there is a slight compressive effect and need for a little more stock to offset this action. The variations in blank diameters due to this cause are very slight, but should not be disregarded if accurate thread rolling is to be done.

Determining the Blank Diameter. — The blank diameter may be determined quite easily by actually rolling threads on blanks the sizes of which are changed as may be required to produce a well-formed thread. While this is the most reliable method, it cannot always be applied, because the stock from which the blanks are to be made is not at hand; in fact, it may be necessary to order the stock from the mill long before it is needed, and then the blank diameter is either determined by calculation or by reference to blank sizes previously tabulated for different screw thread diameters. There are several different rules and formulas for calculating blank diameters, but inasmuch as this diameter is affected by the accuracy required for the rolled thread, the kind of material to be rolled, its composition, and by any decided variation in the physical condition of the surface metal (as, for example, when the "skin" of cold-drawn stock is removed by turning) the impracticability of deducing a rule or formula that may be generally applied is apparent.

According to the practice in different plants where thread rolling is done, there are three general classes of blank sizes, including: (1) Those which are a little larger than the pitch diameter; (2) those which are approximately equal to the pitch diameter; and (3) those which are slightly less than the pitch diameter. The sizes in the first class are intended for screws which are to be rolled as accurately as possible. The difference between the blank diameter and the corresponding pitch diameter varies somewhat for screw threads of different sizes, but, according to average practice, as near as this can be determined, the relationship is about as follows: The blank diameters for screws varying from $\frac{1}{4}$ to $\frac{1}{2}$ inch are from 0.002 to 0.0025 inch larger than the pitch diameter, and for screws varying from $\frac{1}{2}$ to 1 inch or larger, the blank diameters are from 0.0025 to 0.003 inch larger than the pitch diameter. Threads of the second class mentioned, or those rolled from blanks which are equal to the pitch diameter, are sufficiently accurate for many purposes. Blanks of the third class, or those which are slightly less than the pitch diameter, are intended for bolts, screws, etc., which are made to fit rather loosely, a comparatively free fit being desirable in many cases. Blanks for this grade of work, according to common practice, are from 0.002 to 0.003 inch less than the pitch diameters for screw threads varying from $\frac{1}{4}$ to $\frac{1}{2}$ inch, whereas, for screw thread sizes larger than $\frac{1}{2}$ inch, the blank diameters are frequently from 0.003 to 0.005 inch less than the pitch diameter. The blanks for screw threads smaller than $\frac{1}{4}$ inch are usually from 0.001 to 0.0015 inch less than the pitch diameter for ordinary grades of work, and about the same amount larger than the pitch diameter for more accurate screw threads.

The reason why the blank diameter should be somewhat larger than the pitch diameter when a full thread of standard size is to be formed is that the volume of the thread groove extending inside of the pitch line or surface as at *A*, Fig. 3, is less than the volume of the section *B* of the thread extending outside of the pitch surface, the mean radius of section *B* being larger than the radius of *A*. If the blank is made somewhat larger than the pitch diameter, as indicated by the dotted line

above the line representing the pitch diameter, this will offset the difference between the volumes of sections *A* and *B*.

Reciprocating Type of Thread-rolling Machine. — The thread-rolling machine illustrated in Fig. 4 is a horizontal reciprocating type which operates on the general principle illustrated by the diagram, Fig. 1. This machine is one of the designs and sizes manufactured by the Waterbury Farrel Foundry & Machine Co., Waterbury, Conn. The stationary die is securely held at *A* and the movable die *B* is attached to a slide connecting with a pitman *C*. This pitman is operated by a large crank-gear *D* which is driven from a pinion mounted on the driving pulley shaft. This particular machine is arranged for

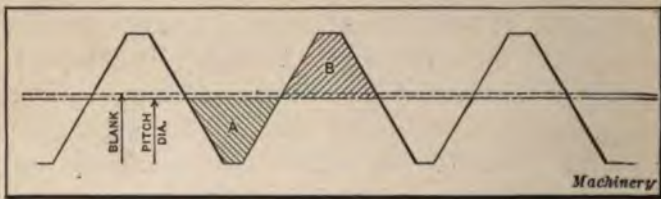

Fig. 3. Diagram showing Relation between Diameter of Blank and Pitch Diameter of Rolled Screw Thread

feeding the blanks by hand, so that it is comparatively simple in design. The blanks to be threaded are placed, one at a time, in the feeding position, the lower end resting against a stop which may be adjusted vertically and insures rolling threads of equal length on the different blanks. Each blank is placed in position, while the slide is returning, and when the moving die has advanced to the right position relative to the stationary die, a "push-finger" starts the blank between the dies. As soon as the blank is caught, it is rolled along between the die faces until it has passed clear across the stationary die; the thread-rolling operation is then completed and the bolt or screw falls into a receptacle. The push-finger is operated by a cam located on the opposite side of the machine from that shown in the illustration. This cam transmits motion through a shaft and lever *E* to the slide carrying the push-finger or "starter," as it is sometimes called.

When exceptionally long blanks are being threaded, a special holder or clip is applied to machines arranged for hand feeding to insure locating the blanks square with the dies. In rolling threads on shorter blanks, such an auxiliary device is not necessary, because the vertical face of the push-finger tends to start a blank square, even though it may be slightly inclined when the push-finger moves forward. On some of these machines, the movable die has a vertical concave groove or pocket cut across the teeth or ridges near the starting end. This groove, which

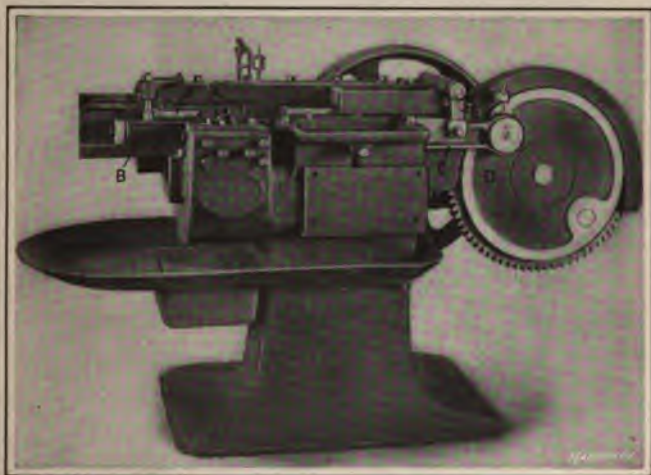

Fig. 4. Reciprocating Type of Screw-thread Rolling Machine arranged for Feeding Blanks to Dies by Hand

has a depth approximately equal to $\frac{1}{2}$ the thread depth, is opposite the end of the fixed die just before the rolling operation begins, and the blank enters it as the push-finger advances. The object of this vertical groove or pocket is to insure starting each blank square with the dies. Most thread-rolling machines are equipped with a pump, tank, and suitable piping for flooding the work with a lubricant.

Another screw-thread rolling machine of the horizontal reciprocating type is shown in Fig. 5. This machine is one of the designs made by the E. J. Manville Machine Co., Waterbury,

Conn. The driving mechanism of this machine is quite similar in its general arrangement to that previously described in connection with the machine shown in Fig. 4. The reciprocating slide which carries the movable die receives its motion from a large crank-gear, as in the former case, which meshes with a pinion on the flywheel shaft. The crank-gear is connected to the reciprocating slide by a pitman. This machine is known as

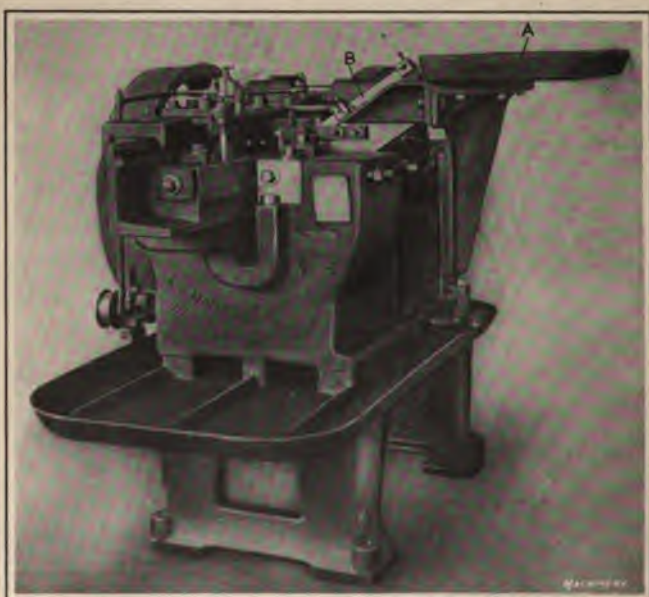

Fig. 5. Reciprocating Screw-thread Rolling Machine equipped with Semi-automatic Feeding Mechanism

the "direct-drive type" to distinguish it from the earlier designs having a crank-gear revolving about a vertical axis and driven through bevel gearing from a horizontal shaft connecting with the belt pulley. The arrangement of the stationary and moving dies and the method of starting each screw blank between the dies at exactly the right time is shown by the diagram, Fig. 6, which represents a plan view. The moving die *A* is carried by the reciprocating slide *B* and the stationary or short die *C* is clamped into an adjustable holder *D*. This holder may be ad-

justed toward or away from die *A* as may be required by the diameter of screw thread to be rolled. The moving die is shown at one end of the stroke. As die *A* moves toward the left, the blank to be threaded is pushed between the two dies by the starter *E*. This starter or push-finger ordinarily is operated by an adjustable cam which transmits motion to it through a mechanism so arranged that either a positive or yielding pressure may be given to the blank as it enters between the dies.

At the starting end of die *C* there is a short blank space which is cut down level with the bottom of the grooves in the rest of the die face. This space provides room for inserting a blank and enables another blank to be placed in position as soon as

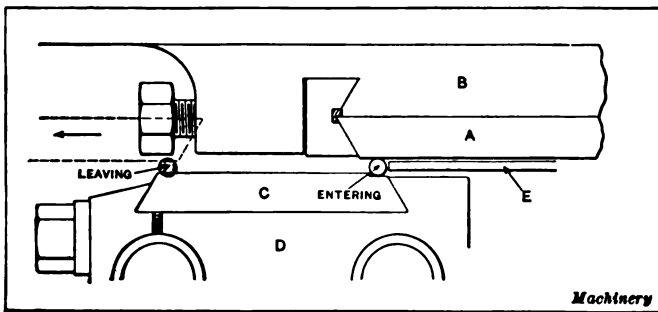

Fig. 6. Plan View of Thread-rolling Dies

starter *E* has withdrawn far enough, without danger of the second blank being dragged in by the moving die before the latter is in position to receive it. It is essential to have the dies properly located relative to each other, and the action of the starter must also be timed so that the blank is pushed forward at the right instant.

Adjustment or Timing of Blank Starter. — The blank starter on the Manville machines is set by first placing the moving slide at the extreme end of its stroke towards the right and then moving it forward about one-eighth inch. The starting cam is then set on its highest point and the starter is adjusted endwise until its end is in line with the ends of the threads on the stationary die. After these approximate adjustments have been made,

a blank is inserted in front of the starter and the machine is turned far enough to revolve the blank forward about half a revolution. The machine is then turned backward and the blank removed to see if the thread rolled by one die coincides with those rolled by the other die. If the thread grooves do not match properly, the position of the starting cam is changed so that it acts either earlier or later, thus forcing the blank between the dies when the latter are in the correct position relative to each other. Another method of remedying this trouble is by slightly raising or lowering one of the dies.

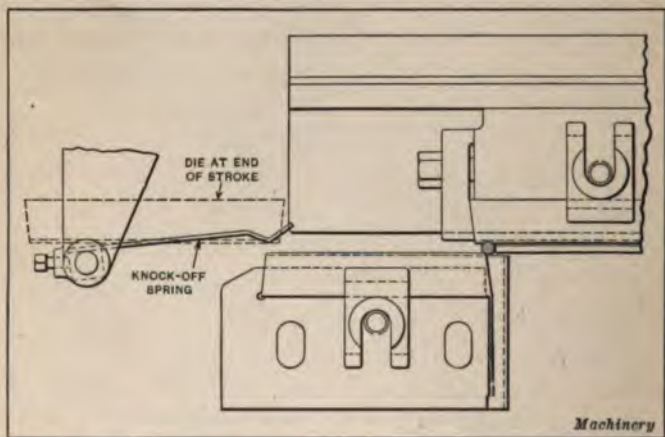

Fig. 7. Plan View showing Relation between Thread-rolling Dies and Knock-off Spring which ejects Threaded Blank at End of Stroke

Ejector of Thread-rolling Machine. — Bolts or screws sometimes stick to the movable die after the thread is rolled. In order to prevent a screw from being caught between the dies on the return stroke, the simple form of knock-off or ejector shown in Fig. 7 is used. A flat spring having a bent end is attached to the frame of the machine in such a position that the screw forces the spring back while it is still between both dies and is firmly held. When the spring returns to its normal position, it pushes the blank forward and away from the movable die so that it cannot be caught between the dies at the beginning of the return stroke. This knock-off is located at *F* on the machine

shown in Fig. 4. The same general type is also used on the machine illustrated in Fig. 5.

Semi-automatic Feeding Mechanism. — Most thread-rolling machines are either arranged for feeding blanks to the dies by hand or are equipped with an automatic feeding mechanism. In some cases, however, a semi-automatic feed is employed, and this type will be referred to before describing the kind which is entirely automatic in its operation. The particular thread-rolling machine shown in Fig. 5 illustrates how this semi-automatic feeding arrangement is applied to some of the Manville machines.

As previously explained, when blanks are fed to the dies entirely by hand, each blank must be placed in the feeding position. This method has proved very satisfactory, because the operator soon becomes so expert that the feeding is done almost as regularly as when some form of mechanical feeding device is employed. The hand-feeding method, however, requires the constant attention of the operator, which is not the case with the semi-automatic type. When the latter is applied to a machine, the operator, instead of inserting a blank between the dies for each stroke, simply transfers a number of blanks from the shallow pan *A*, Fig. 5, to the inclined tracks *B* which convey the blanks down to the dies. The blanks feed down these tracks, by gravity, to a mechanism which automatically presents each successive one to the thread-rolling dies for every stroke of the machine, the same as when an automatic feeding mechanism is used; therefore, when the machine has a semi-automatic feed, it is simply necessary for the operator to keep the chute or tracks loaded with blanks. This type of feeding mechanism is especially adapted for certain classes of blanks which are not readily lifted and caught by a slotted swinging plate, such as is used with the automatic feeding mechanism. When the heads of the blanks are comparatively large and the shanks short, or if the shanks are unusually long, difficulty may be experienced with a feeding mechanism which is entirely automatic.

Automatic Feeding Mechanism. — Many of the thread-rolling machines now in use are equipped with an automatic feeding

mechanism which is so arranged that the blanks to be threaded are transferred from a hopper to the dies entirely by mechanical means. A machine made by the Waterbury Farrel Foundry & Machine Co., which is equipped with an automatic feeding mechanism, is illustrated in Fig. 8. The entire feeding mechanism is mounted upon a hinged or pivoted member so that it can be swung to one side as illustrated by Fig. 9, in case it is desir-

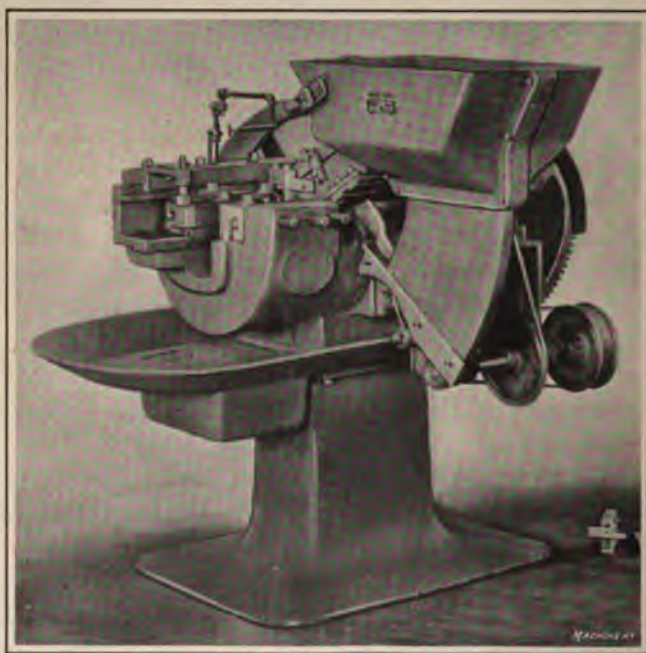

Fig. 8. Thread-rolling Machine provided with Automatic Feeding Mechanism

able to feed the machine by hand. For instance, if only a few thousand screws or bolts of given size were required, the hand feed would doubtless be preferred to the automatic feed, because the latter requires more or less adjustment for adapting it to work of a different size.

A large number of the blanks to be threaded are placed in the hopper *A*, Fig. 9, and extending vertically through this hopper there is a blade *B*. This blade is pivoted at the inner end and

swings up and down through the mass of blanks when the machine is in operation, the swinging movement being derived from a roller *C* attached to the gear *E*. A vertical slot or opening extends along the upper edge of the blade and this slot is a little wider than the diameter of the screw blank bodies; consequently, as the blade moves up through the mass of blanks in the hopper some of them fall into the slot and are caught by the heads. When the blade reaches the top of its stroke, it remains

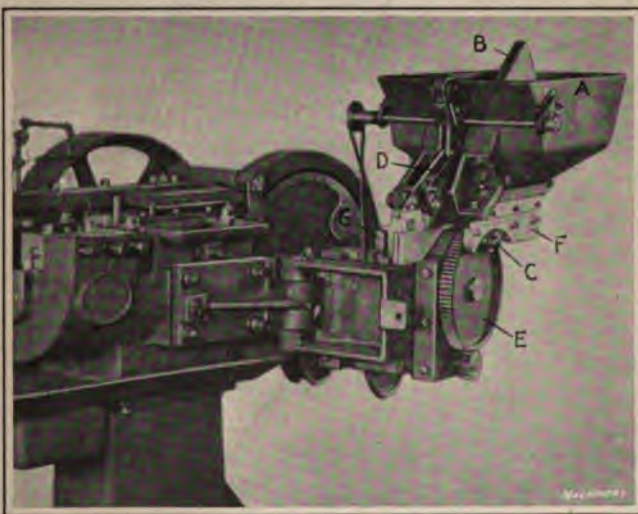

Fig. 9. Feeding Mechanism of Machine shown in Fig. 8 swung out of the Way to permit Hand Feeding

stationary for a short time, and as the upper edge is inclined considerably, the blanks which were caught slide down to the lower end of the blade and then pass into the chute *D* which leads down to the dies when the mechanism is in the feeding position. The plate *F* attached to the oscillating blade or "center-board" of the hopper has a circular section which is concentric with the path of roller *C* and provides the dwell of the blade at the top of the stroke. The blade remains stationary long enough for all the blanks to slide down into the chute. Near the point where the blanks leave the blade, there is a

rapidly revolving toothed wheel which is so located and formed that any blanks which are not suspended by the heads and in the proper position are dislodged and thrown back into the

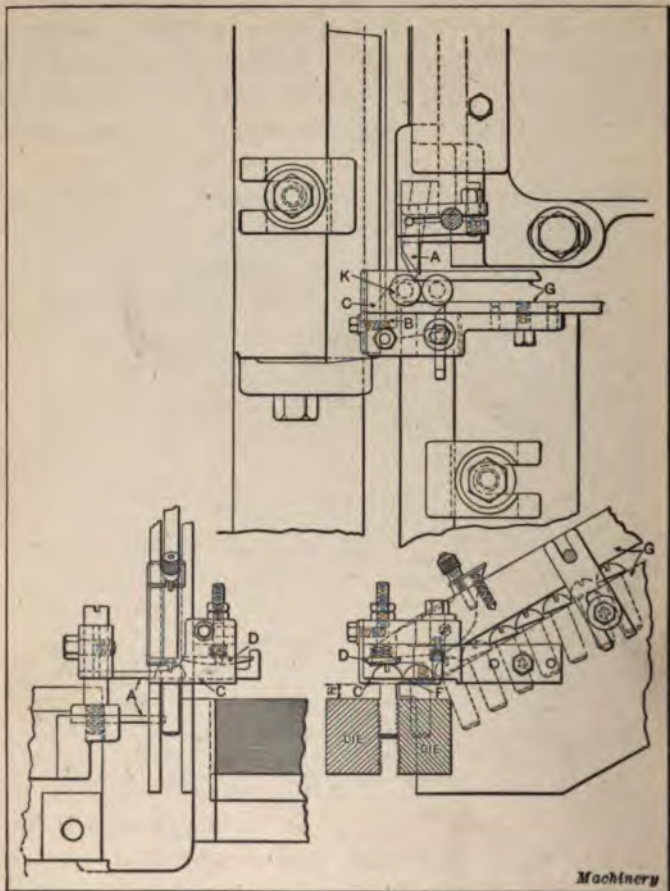

Fig. 10. Escapement or Cut-off Mechanism at Lower End of Feed-chute for Feeding Blanks One at a Time to Dies

hopper. In this way, the entrance to the chute is kept clear and clogging prevented.

One of the interesting features of this mechanism is the escapement at the lower end of the chute which automatically feeds one blank at a time to the dies. At the lower end of the

chute there is a V-shaped cut-off finger *A*, Fig. 10, which moves in at the proper time and separates the lowest blank *K* from the others in the chute. This cut-off finger derives its movement from a cam surface on the main slide. The blank which is separated from the others by the cut-off finger is placed in front of the push-finger *B* which at the proper time advances it to a point where it is caught between the dies. The action of the cut-off finger is so timed that it remains in the inner position and prevents the column of blanks from descending until the push-finger is in position to serve as a stop; the cut-off finger then withdraws and the blanks descend far enough to allow the lowest one to be separated from the others as the cut-off finger again advances on the next succeeding stroke. The blank passes around a corner after leaving the cut-off finger, so that its movement is then parallel to the thread-rolling dies. While the blank passes through this parallel section of the guide plate *C*, the head is held downward upon the guide by a spring plate *D* above. This feeding mechanism is so arranged that the blanks are suspended by their heads from the time they are caught by the swinging hopper blade until they are gripped between the threading dies, unless it is necessary to roll a thread close up to the head. In that case, the guide plate which holds the blank after it leaves the cut-off finger is changed. The surface of plate *C* is beveled and plate *F* on the opposite side is reversed, so that the blank is lowered to a point where the under side of the head is level with the upper edges of the dies. When the thread does not need to be rolled close up to the head, each blank is suspended from the head until it is pushed forward and is caught between the dies; consequently, the length of the thread part depends upon the vertical distance x between the guide plate and the dies. This distance (which is very small for threading close to the head) may be varied for rolling threads of different length by adjusting the entire feeding mechanism vertically. The screw for making this adjustment is located at *G*, Fig. 9.

In adapting this mechanism to different sizes and shapes of blanks, a certain amount of adjustment is necessary, as previ-

ously mentioned. In some cases, it may also be necessary to alter the end of cut-off finger *A*, Fig. 10, as, for example, when the blanks have countersunk or oval heads. For instance, in the case of a countersunk head, the edge of finger *A* would be provided with a groove for engaging the blank heads, in order to prevent any tilting action. The chute *G* leading from the hopper to the dies is adjusted in accordance with the diameter of the work, and the "pick-up" blade in the hopper has a removable top which can be replaced if necessary. A given width of

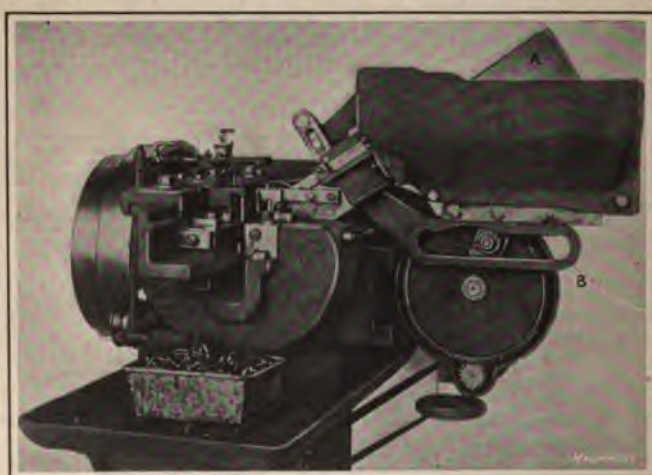

Fig. 11. Side View of Automatic Feeding Mechanism applied to Thread-rolling Machine

slot can be used for a limited range of blank diameters without change. The automatic feeding mechanism of a machine intended for comparatively light blanks is equipped with what is known as a "vibrator." This vibrator consists of a rotating shaft carrying pins inserted in a flange and arranged to strike fixed pins, thus causing a rapid succession of light blows. This vibrator is to prevent the blanks from sticking in the feed-chute, as they sometimes tend to do when very light, and especially if covered with oil.

The automatic feeding mechanism of a thread-rolling machine made by the E. J. Manville Machine Co. is shown in Fig. 11.

The slotted blade which oscillates through the center of the hopper and its operating mechanism is clearly shown in this illustration. The lower edge of this blade *A* is bolted to the swinging arm *B* which derives its motion from the crank-pin roller *C* attached to gear *D*. This blade has a positive upward and downward motion, the roller engaging a slot formed in the arm. The blade is shown at the upper end of its stroke, the roller being in contact with the circular concentric surface of the swinging arm. This mechanism, like the one previously described, is so arranged that the descending row of blanks is held back by a cut-off device until, at the proper instant, the lowest blank is separated from the others and forced outward in front of the pusher slide which then starts it between the stationary and moving dies. In conjunction with this feeding mechanism, there is also a simple mechanical device which automatically throws back into the hopper all blanks that are not hanging in the right position as they pass into the inclined tracks leading to the dies.

Feeding Mechanism for Headless Blanks.—The thread-rolling machine illustrated in Fig. 12 has a magazine feeding attachment that is designed for feeding automatically headless blanks which may require a screw thread on one end, both ends, or a thread extending the entire length. The blanks are placed horizontally in the magazine or hopper by the operator. At the lower end of the incline in the magazine hopper, there is an agitator arranged to prevent the blanks from becoming clogged. The lower blank at the end of the incline is transferred to the dies or starting position by an oscillating segment, which, as each successive blank is transferred, changes it from a horizontal to a vertical position. This segment has a notch that receives the lower blank which is in a horizontal position when it leaves the magazine. The blank is then placed in a vertical position after which it drops by gravity from the segment and in front of the starting slide plate. The position of the blank relative to the dies is controlled by an adjustable depth gage, and, at the proper time, it is pushed forward and gripped by the moving die and is then rolled through the die in

the usual manner. The turning of the segment for changing the position of the blank from horizontal to vertical is effected by a spring, and the return movement is positive, being derived from a cam. This arrangement is to avoid any damage to the machine in case a blank should become lodged partly in the segment and partly in the magazine. The notch in the segment which receives the blank has a spring finger so arranged that, when the segment swings the blank to a vertical position, if the blank should fail to drop out of the segment or drop only part

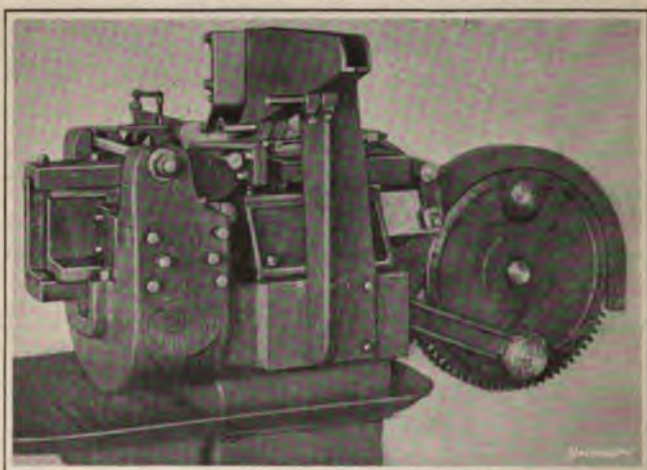

Fig. 12. Machine provided with Magazine Feeding Attachment designed for Handling Studs or Headless Blanks

way, no damage can occur to the machine or to the feeding mechanism.

This design of magazine feed is adapted especially for threading parts such as are found in harvester machinery, various forms of special bolts, turnbuckle screws, skate screws, etc. One end of a piece may have a right-hand thread and the other end, a left-hand thread, but, whenever threads are rolled simultaneously on both ends of the blanks, the diameter and pitch must be the same. A few examples showing, in a general way, the kind of work for which this thread-rolling machine may be used are illustrated in Fig. 13. The part illustrated at *A* has a

thread rolled on one end only. The rod *B* has a right-hand thread on one end and a left-hand thread on the other end. The piece shown at *C* is an example of work requiring a thread the entire length of the blank, and sketch *D* shows a lag-screw thread and a gimlet type of point. When threads are to be rolled simultaneously on each end and an unthreaded portion is to remain between the threaded sections, as illustrated at *B*, the dies are separated by one or more fillers, according to the length of the unthreaded part. The special thread-rolling ma-

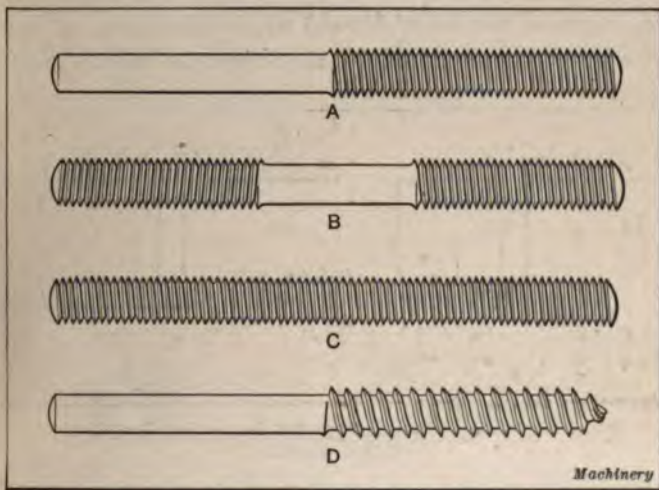

Fig. 13. Examples of Work threaded by Machine shown in Fig. 12

chine illustrated in Fig. 12, equipped with the magazine just described and extra deep dies, is made by the Waterbury Farrel Foundry & Machine Co.

Regulating Length of Rolled Thread. — The maximum length of thread which can be rolled in any one machine depends upon the size and design of the machine. In general, the maximum length of the thread is nearly equal to the full face width of the deepest die the machine is capable of using. It is not practicable to roll a thread the entire depth of the dies, as an allowance of about $\frac{1}{8}$ inch should be made. The thread-rolling machines made by the Waterbury Farrel Foundry & Machine Co. for

rolling exceptionally long threads have one or two tie-rods extending across the frame above the dies to take part of the strain when threads are being rolled. The machine illustrated in Fig. 12 is provided with one of these tie-rods. This reinforcement prevents the dies from springing apart when rolling exceptionally long threads and insures accurate work. A tie-rod does not interfere with the operation of an automatic magazine feeding mechanism nor with feeding the machine by hand, although the work must not project above the dies far enough to strike the tie-rod.

The length of the rolled thread within the range of any one machine may be regulated in three general ways: First, by

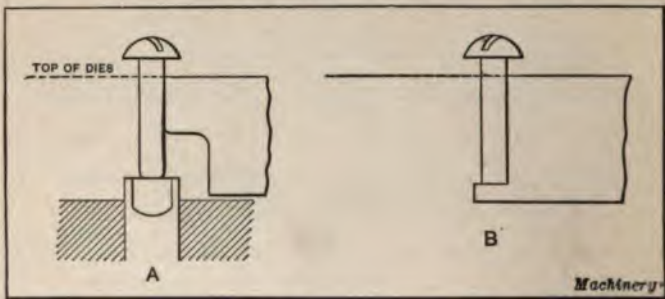

Fig. 14. Two Forms of Stops for Regulating Length of Rolled Thread

placing the end of the blank against some form of stop which is located below the top of the dies a distance equal to the length of thread to be rolled; second, by suspending the blanks for screws, bolts, etc., from the heads; and, third, by cutting away the ridges or "threads" on the dies down to a point from the top equal to the length of the unthreaded section. When a thread-rolling machine is fed by hand, the lower end of each blank ordinarily is placed against some form of stop, except when a thread is required close up to the head, in which case the under side of the head serves as a stop and drops down to the level of the dies. A stop may be in the form of an adjustable depth gage as indicated at A, Fig. 14, or the vertical position of the blank relative to the dies may be controlled by a

projecting end or shoulder on the starter or push-finger, as illustrated at *B*. The latter has the disadvantage of not being adjustable.

With a machine of the design shown in Fig. 8, which has an automatic feed, the length of the thread is adjusted, as previously mentioned, by simply raising or lowering the entire feeding mechanism by means of a single screw. This method of regulating the length is possible because the blanks are suspended by the heads until caught between the dies, except when the lower end of the mechanism is changed for rolling a thread close up to the head, in which case the blank is pushed down to the level of the dies.

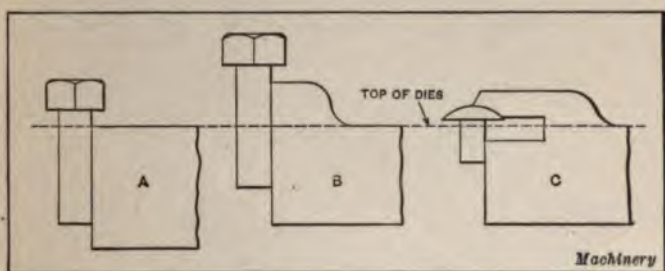

Fig. 15. Push-fingers or Starters for Thread-rolling Machines

Shape and Location of Blank Starters. — The blank starter or push-finger of a thread-rolling machine is usually in the form of a rectangular plate having a vertical edge which comes into contact with the body of the blank and pushes it squarely between the dies at the proper time. A simple form of push-finger is illustrated at *A*, Fig. 15. The width of this starter should be a little less than the space between the dies. It is essential to use a starter which tends to hold the blanks square or perpendicular to the line of travel of the movable die. One that is not properly formed or located relative to the blank may, by acting against one end, tilt the blank from a vertical position. If a comparatively short thread is to be rolled and the blank extends considerably above the dies, an offset starter may be required (see sketch *B*) to secure greater contact along the blank body.

In some cases, a plain vertical edge on the starter is not sufficient, and it is necessary to make a special form. An example is illustrated at *C*. In this case, the blank is very short, and, as a space is required to clear the guide plate of the automatic feeding mechanism, the starter is made with an upper section or extension which bears against the oval head of the blank as the illustration indicates. By supporting the blank at both ends, it can be pushed forward without tilting it. The

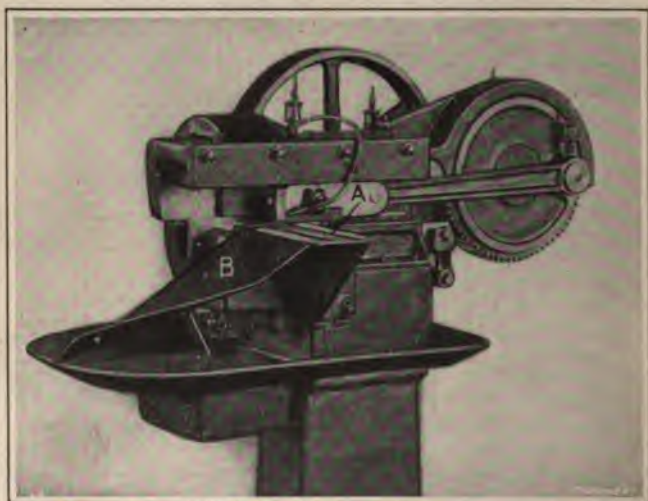

Fig. 16. Side-feed Type of Thread-rolling Machine designed for Rolling Threads on Ends of Slender Wire Rods, etc.

exact shape and position of these special starters depend upon the length of the blank and the shape of the head.

Side-feed Type of Thread-rolling Machine. — The design of thread-rolling machine shown in Fig. 16 is intended especially for rolling threads on the ends of comparatively long slender parts, such as wire rods, the spokes of wire wheels, and other similar classes of work which cannot be handled to advantage in a machine in which the work is held vertically while the thread is being rolled. With the side-feed type of machine, the work is rolled while in a horizontal position so that long slender parts can be operated upon without difficulty. When

this machine is in operation, the blanks to be threaded are placed against edge *A* on the table bracket and against a depth gage which may be adjusted for any length within the capacity of the machine. The part to be threaded is then started between the dies automatically by means of a push-finger the

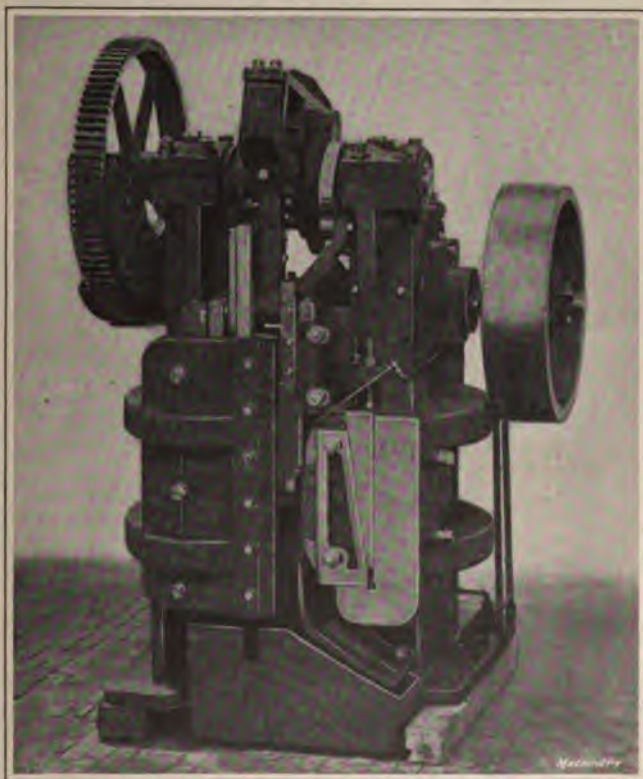

Fig. 17. Vertical Type of Thread-rolling Machine

same as on the machines previously referred to. As each threaded part leaves the dies it rolls down the inclined plate *B* and into a receptacle.

Vertical Thread-rolling Machine.— The thread-rolling machine made by the National Machinery Co., Tiffin, Ohio, is a vertical design. This machine (see Fig. 17) occupies a comparatively small floor space and it is claimed that the dies,

which are also in a vertical position, last longer than horizontal dies, because the scale and foreign matter are more readily washed away by the lubricant, which continually floods the dies. The front and side elevations of the machine shown in Fig. 18 illustrate the arrangement of the different parts. The stationary die is located at *A* and is provided with adjustments at the side and back. The reciprocating slide which carries the

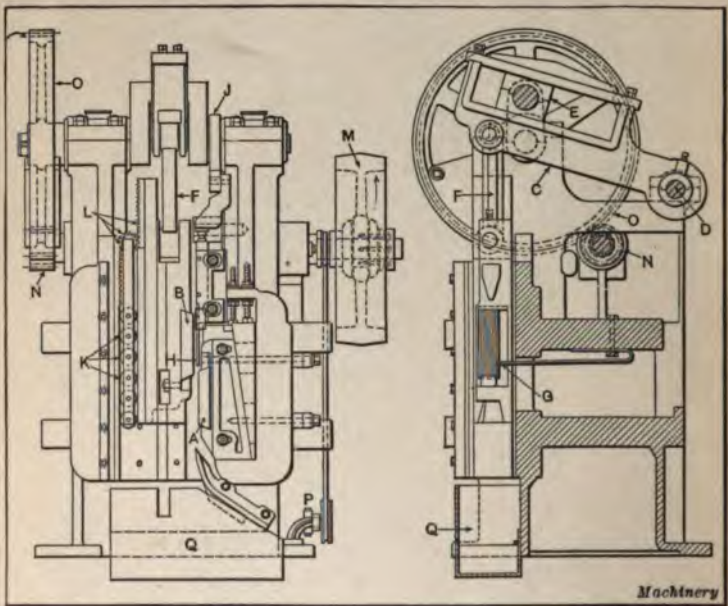

Fig. 18. Front Elevation and Sectional View of Vertical Machine shown in Fig. 17

moving die *B* is operated by a yoke *C* connecting with the crankshaft of the machine. This yoke is pivoted at *D* and engages block *E* mounted on the crankpin. The oscillating motion of yoke *C*, which connects with the reciprocating slide by rod *F*, gives a slow downward stroke to the die and a quick return movement.

The blank upon which a thread is to be rolled is inserted horizontally in a gap between the dies at the top and against the end of a gauge *G* at the rear. Then the starter *H*, which derives

movement from a cam *J* on the main shaft, pushes the blank between the dies at the right moment, after which the downward motion of the moving die causes the blank to roll between the dies until it drops out at the lower end with a complete thread formed on it. In order to reduce friction and wear to a minimum, the movable slide is backed by a train of hardened steel rollers *K*. The frame carrying these rollers is moved up and down by the double rack and pinion mechanism shown at *L*. The machine is driven by a belt operating on the flywheel pulley *M* which drives the crankshaft through pinion *N* and gear *O*. This flywheel is not positively connected to its shaft, but drives through frictional surfaces which act as a safety relieving device for the machine. For instance, if the dies should become loose through neglect on the part of the operator or the machine should stall as the result of some accident, the flywheel would slip between friction flanges and thus dissipate its excess energy so as to avoid damaging parts of the machine. A lubricating pump *P* connecting with the oil reservoir *Q* keeps the dies flooded continually with oil, thus removing scale and dirt from the grooves in the die faces.

Rotary Thread-rolling Machine. — The rotary thread-rolling machine made by the Acme Machinery Co., Cleveland, Ohio, differs radically in its design from the types previously described. This rotary machine, which is illustrated in Fig. 19, is so called because one of the dies revolves continuously in one direction. This revolving die is cylindrical, forming a complete circle, whereas the other die is the segment of a circle. This segment-shaped die remains stationary. The part upon which a thread is being rolled passes between the revolving die and the fixed die. The adjustment of the distance between the two dies for securing diameter variations is regulated by means of the handwheels shown. The segment-shaped die is carried by a heavy casting that is eccentric to the shaft. By loosening one of the handwheels and tightening the other, the segmental die is advanced toward or withdrawn from the circular die. The bolt or other part to be threaded is placed in a holder, and the operator, by moving a handle, moves the work forward to a point where it is

caught between the dies. Just as soon as the thread-rolling operation begins, the carriage or holder drops back into the feeding position. There are four opportunities for feeding a blank between the dies for each revolution.

A number of advantages are claimed for the rotary type of machine. In the first place, the bolt or rod is fed into the machine while in a horizontal position, so that long rods such as

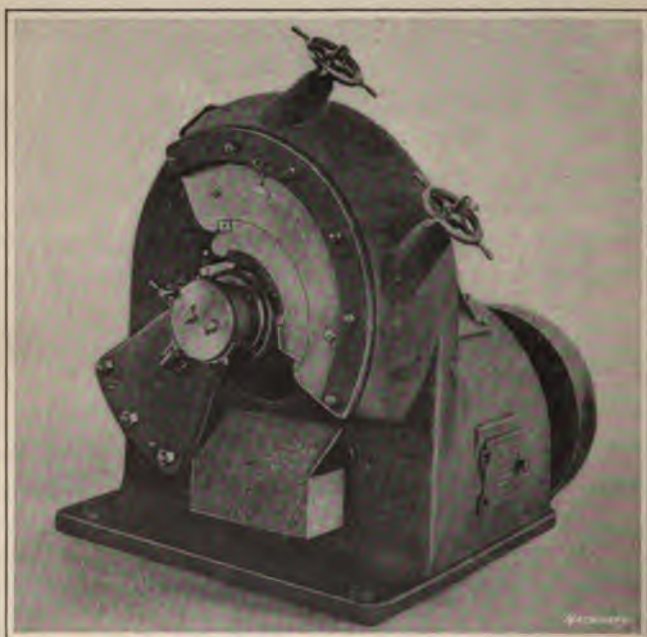

Fig. 19. Rotary Type of Thread-rolling Machine

are required for car trusses, bridges, etc., can be threaded with this machine. Other advantages claimed by the manufacturer are as follows: The massive compact construction adapts the machine for rolling larger sizes than has generally been considered possible heretofore. The machine is exceptionally durable, because it has a rotary motion constantly in one direction and, for that reason, runs much easier and will last longer than a machine having a reciprocating motion. The circular dies are more durable than straight or flat dies, because when a bolt

is rolled between two flat dies the rolling process always begins at the same point, but with circular dies the bolt enters and the rolling begins at different points; consequently, the breaking down process or the beginning of the thread-rolling operation is not confined to one particular place on the dies, the result being that the wear is general and uniform over the entire die surface. A further advantage is claimed in regard to the speed of the machine, the contention being that there are four chances in each revolution for feeding a blank so that the machine does not need to run nearly as fast as when there is but one chance to feed a blank for each revolution. At the rear of the main spindle of this rotary machine there are two spiral springs and means for putting them in tension. This is regarded as an important feature, because it keeps the round die in pitch with the segmental die and, at the same time, provides a certain amount of elasticity for the shaft.

Sizes of Screw Threads formed by Rolling. — Thread-rolling machines are especially adapted for small and medium sized screws, although some machines are capable of rolling fairly large threads. The machines listed by several different manufacturers have nominal rated capacities for screw thread diameters varying from $\frac{1}{16}$ up to 2 inches. These rated capacities do not represent the maximum diameters for which the machines can be used. For instance, a 1-inch machine is sometimes used for rolling $1\frac{1}{4}$ -inch diameters or even larger sizes. The rated capacity represents what manufacturers believe to be the largest size of thread for which the machine should be used if the best grade of work is desired. The maximum diameter may depend upon the depth of the dies used. For example, if a machine has a rated capacity of $\frac{1}{2}$ inch, this applies to dies of standard depth, but if the "maximum depth" dies are used, naturally the largest diameter that can be rolled is diminished accordingly. The machines shown in Figs. 4 and 5 have a rated capacity of $\frac{1}{2}$ inch. Fig. 8 shows a $\frac{3}{8}$ -inch size, and Fig. 11 a $\frac{1}{4}$ -inch size. The vertical machine illustrated in Fig. 17 has a rated capacity of 1 inch. This same design is also made in $1\frac{1}{2}$ - and 2-inch sizes. The rotary machine shown in Fig. 19 is made in $\frac{1}{2}$ -, 1-, and 2-inch sizes.

An interesting type of thread-rolling machine, made by the Waterbury Farrel Foundry & Machine Co., intended for rolling threads on very small blanks having short shanks, is illustrated in Fig. 20. The rated capacity of this machine is $\frac{1}{8}$ inch. The important feature of the design is that the die faces are located at right angles to the chute of the automatic feeding mechanism, so that the blanks enter between the dies at the lower end without changing from the inclined position in which they lie in the feed-chute to a vertical position. With the ordinary arrange-

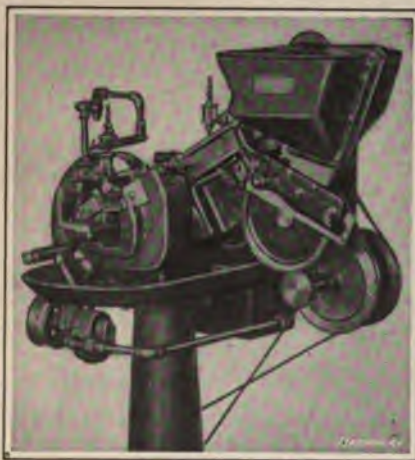

Fig. 20. Machine of Reciprocating Type designed for Very Small Work

ment, it is necessary for the blanks to assume a vertical position after leaving the feed-chute, because the die faces are vertical instead of being inclined. By locating the dies in the inclined position, short and very small blanks may be fed automatically, and it is not necessary to use a separator or cut-off blade at the foot of the chute, thus simplifying the construction. The pick-up blade

in the hopper is provided with a groove or channel along its top instead of a slot for handling the short blanks.

Time required for Rolling Screw Threads. — The time required for rolling screw threads or the rate of production varies greatly for machines of different sizes. For instance, the machine shown in Fig. 20, which has a rated capacity of $\frac{1}{8}$ inch, is capable of threading screws at the rate of 125 per minute, whereas a 1-inch machine of the same make will roll threads on about 30 pieces per minute. In a general way, these figures represent approximately the maximum and minimum rates of production for thread-rolling machines, the rate of production increasing as the size of the machine decreases. For instance, a $\frac{1}{4}$ -inch ma-

chine may roll 70 or 80 screw threads per minute; a $\frac{1}{2}$ -inch machine, 45 or 50 per minute; and a $\frac{3}{4}$ -inch machine, about 35 per minute. A comparison of these figures with the rates of production attained by other methods of forming screw threads will indicate the superiority of the thread-rolling machine for work within its range.

Advantages and Range of Thread-rolling Process. — The principal advantage of the thread-rolling process is that it is the most rapid and economical method of forming screw threads, assuming that the work is suitable for a thread-rolling machine. Thread-rolling machines are used very extensively for threading machine screws and various forms of special screws, track bolts and bolts for numerous other purposes, wood-screws, lag-screws, slender wires in a great variety of lengths and sizes requiring long or short threads and, in general, almost all small and medium-sized screws and bolts which are required in quantities large enough to warrant the use of a thread-rolling machine. Aside from the speed or efficiency of the thread-rolling process, one of the important advantages claimed for rolled screw threads is their strength as compared with threads formed by cutting. Extensive experiments conducted at one of the leading universities showed that the average rolled thread tested had an elastic limit 13 per cent higher than the elastic limit of a cut thread of corresponding size and material. The following explanation of the comparative effects of the rolling and cutting processes on the elastic limit and ultimate tensile strength of screw threads is given by the E. J. Manville Machine Co.

“In rolled or drawn round stock, the fiber or grain of the steel is usually parallel with its axis, its weakest section being at the center of the rod. The outside section of cold-rolled or drawn steel acts as a cover for the inner fibers and preserves the strain developed during the process of drawing or rolling to size. To cut into this wall or outside covering, it is apparent that the strain within is somewhat released by cutting the threads, which tends to sever the fibers; therefore, the threaded part of a piece of drawn or rolled steel is of lower tensile strength than the unthreaded portion. In rolling threads on the same material, the

blank is subjected to very severe treatment in the operation of cold forging, which produces a weaving or crimping of the fibers within, thus adding strength and toughness to the material. It is, therefore, evident in a comparative test of two threaded pieces of the same size and material that the rolled thread blank is invariably of higher tensile strength than the cut thread."

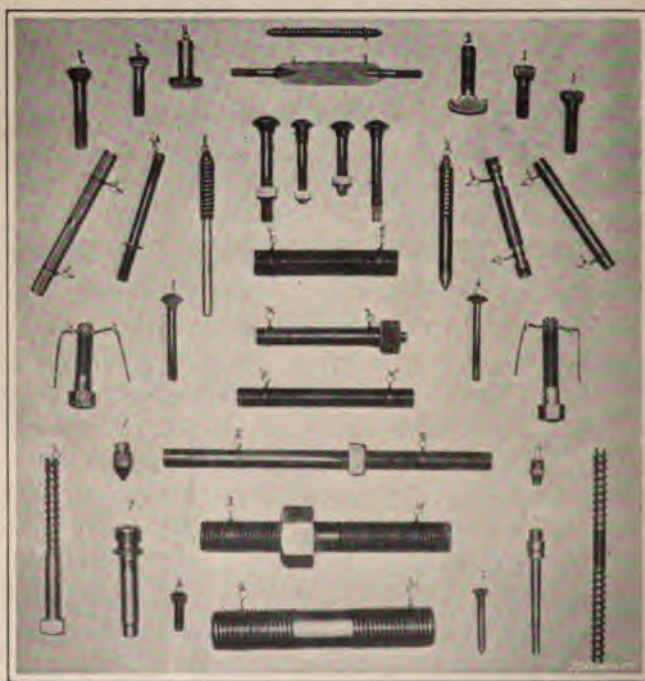

Fig. 21. Miscellaneous Examples of Rolled Screw Threads

Another advantage of the rolling process which may be of considerable importance in some cases is that no stock is wasted as when a thread is cut, because a blank smaller in diameter than the required screw thread is used when the thread is formed by rolling. The surface of a rolled thread is also harder than the surface of a cut thread, especially if the outer part of the stock has a scale which is rolled into the thread, thus making the surface harder and better able to withstand wear.

A general idea of the range of work which can be threaded to advantage by the rolling process is indicated by Fig. 21, which shows a variety of samples of different shapes and sizes. While thread-rolling machines are designed primarily for producing screw threads, they may be used to advantage in some cases for knurling, lettering, marking, grooving, and even for such operations as forming the teeth of small pinions. When these special operations are performed, the machine must, of course, be equipped with suitable dies. While thread-rolling machines are used principally for threading the ordinary commercial quality of screws, bolts, studs, etc., accurate screw

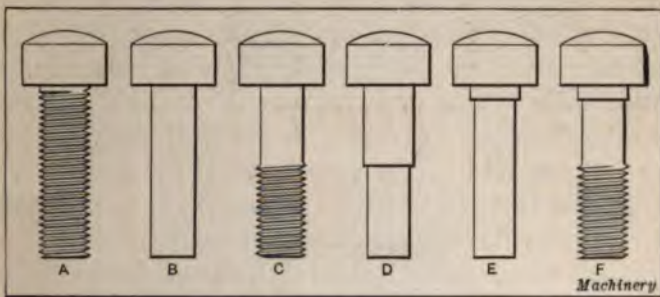

Fig. 22. Three Methods of making Blanks for Machine Screws

threads may be produced by the rolling process, which has even been employed for making screws for micrometers.

Blanks for Machine Screws. — When the threads of machine screws are to extend close to the head as illustrated at *A*, Fig. 22, the screw blank *B* is simply made to whatever diameter will enable a thread of the required size to be produced by the rolling process. If the body of the machine screw is only to be threaded part way, which is the usual practice, the finished screw will appear as illustrated at *C*, provided the form of blank shown at *B* is used. The thread in this case is larger in diameter than the unthreaded body of the screw, simply because the upper section of a rolled thread is formed by forcing the metal above the original surface of the blank as previously explained. While the form of screw shown at *C* may be used for many purposes, it is objectionable for some classes of work, and in such

cases it is necessary to make the body of the screw full size between the head and the threaded portion. The form of blank shown at *D* may be used to secure a body having the same outside diameter as the screw thread. A modification of blank *D* is shown at *E*, and the threaded screw at *F*. In this case, there is simply a short bearing surface beneath the head, which is full size or as large in diameter as the threaded part. While a machine screw of this kind is inferior to the form obtained with blank *D* for general use, it may be satisfactory in some cases and has the advantage of being easier to produce in the header.

Stock for Thread Rolling. — The stock suitable for thread rolling is soft steel and may contain from about 0.07 to 0.12 per cent of carbon. Iron of ordinary quality is not adapted to the thread-rolling process, because of its fibrous structure, which makes it liable to split or fracture as the result of the pressure due to thread rolling. According to the E. J. Manville Machine Co., a "liquor-finished" soft steel wire is the stock to use for obtaining the best results with a minimum of wear on both the header and the thread-rolling dies. A good grade of annealed and cleaned wire is recommended if the liquor-finished wire cannot be obtained. The stock recommended by the Waterbury Farrel Foundry & Machine Co. is of the following composition: Carbon, from 0.08 to 0.12 per cent; manganese, from 0.35 to 0.45 per cent; phosphorus, from 0.03 to 0.04 per cent; and sulphur, from 0.03 to 0.04 per cent. This material has a tensile strength of about 56,000 pounds per square inch.

Making Flat Thread-rolling Dies. — The grooves in the rolling faces of flat dies may either be planed or milled. A simple method is to plane one groove at a time in a shaper. The tool used should be shaped on the cutting end to conform to the cross-sectional shape of groove required; the distance between the grooves is made equal to the pitch of the thread. While the dies can be made in this way, it is preferable to mill the grooves by using a milling machine equipped with a multiple cutter. The form of cutter or "hob" commonly used has teeth which are relieved like a form milling cutter and are not helical like the teeth of a tap, but are ar-

ranged in annular or parallel rows that are perpendicular to the cutter axis. When the parallel grooves are being milled in the face of a die, the latter must be inclined relative to the cutter, so that the angle α , Fig. 23, of the groove will correspond to the helix angle of the screw thread at the pitch diameter. The tangent of this angle equals the pitch of the thread divided by the circumference of the blank to be threaded, which corresponds approximately to the pitch circumference of the screw.

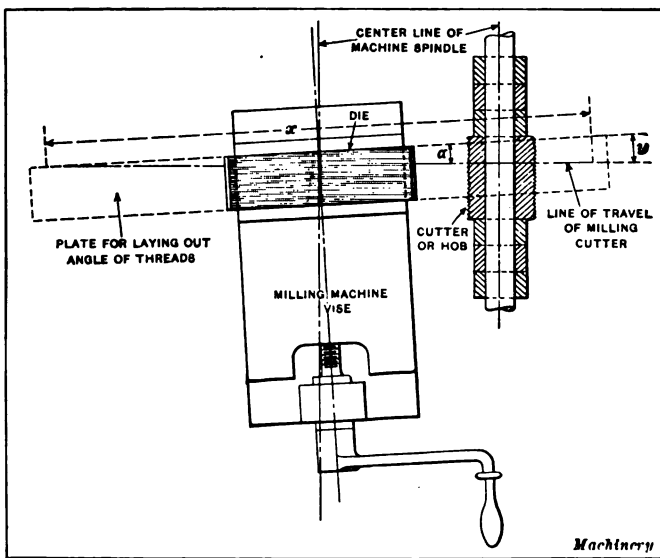

Fig. 23. Plan View illustrating how Teeth of Flat Thread-rolling Dies are milled

The angle may also be determined without calculation in the following manner: Multiply the circumference of the blank to be threaded by any number that will give a product equal to approximately three times the length of the die, and lay off this distance x , Fig. 23, along the edge of a parallel strip or plate which is clamped in the machine vise. The outline of this parallel strip is indicated by the dotted lines in the illustration. The pitch of the thread is next multiplied by the same number previously used to obtain dimension x , and a dimension y equal to the product is laid off at right angles to the parallel strip. A

diagonal line connecting the points located in this way will represent the angle α to which the milling machine vise should be set. By traversing the diagonal line past the sharp end of a pointer clamped to the cutter-arbor, the angular adjustment may easily be made. The reason for increasing dimensions x and y as previously explained is to reduce by one-third any error of the angle. If the die is wider than the cutter, the entire face of the die may be milled by simply taking two cuts across it. When the die is milled in this way, it is very essential after taking one cut across the die face to accurately match the milling cutter with the grooves previously machined.

The teeth of dies used for rolling U. S. standard threads, V-threads, or Whitworth threads have a uniform cross-sectional shape from one end of the die to the other, with the possible exception of a short length near the ends which is relieved. This relief is provided at the ends so that the work will roll off of the die without being marked by the corner. The teeth of dies intended for rolling square threads or those of special form, such as are found on large screws, are not of uniform cross-sectional shape, but are made V-shaped at the starting end so that the formation of the thread groove is gradual. If dies for rolling threads of the classes referred to were made with teeth of uniform section throughout their length, the flat tops of the teeth would tend to compress the metal inward in a radial direction, instead of displacing it to form a thread, and the blank would be elongated by the rolling process.

The accuracy of a rolled thread depends very largely upon the accuracy of the die and the cross-sectional shape of its teeth. The included angle of these teeth is one of the essential points. This angle should be somewhat less than the included angle of the thread to be rolled. For instance, dies for rolling U. S. standard threads should have teeth with an included angle of about $58\frac{1}{2}$ degrees instead of 60 degrees, in order to produce a 60-degree rolled thread. This reduced angle is necessary on account of the elasticity in the stock, the effect of which is to cause the lower part of a rolled thread to spring back slightly after leaving the die, thus increasing the angle so that it is 1 or $1\frac{1}{2}$

degree larger than the angle of the die teeth. Aside from this modification of the angle, the teeth or ridges are of the same cross-sectional shape as the corresponding thread groove.

Thread Rolling in the Screw Machine. — The circular threading roll or disk that is used when threads are rolled in an automatic screw machine or turret lathe has a thread on its edge or periphery which corresponds as to shape and pitch with the thread to be rolled, and this roll is forced against the screw blank while the latter is revolving. Fig. 24 illustrates how a

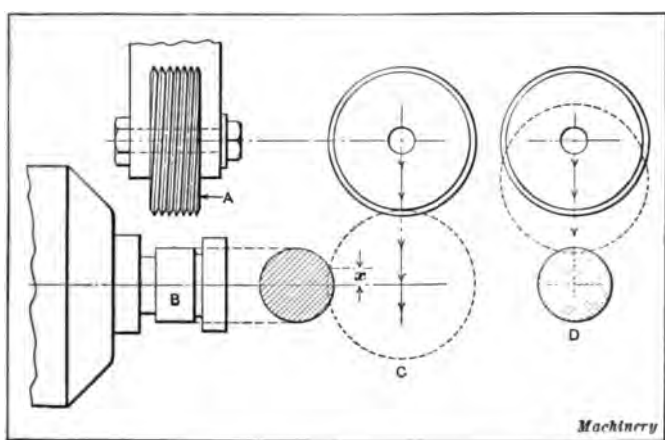

Fig. 24. Methods of rolling Screw Threads on Automatic Screw Machines

circular roll may be applied. The unthreaded blank is held in the machine chuck and revolves about its axis. In screw machine practice, the threading roll *A* is usually mounted in a holder attached to the cross-slide of the machine. The roll is mounted on a pin or bolt so that it is free to revolve when brought into contact with the rotating piece to be threaded. A thread is formed (in this case on surface *B*) when the roll is forced against the work with sufficient pressure to leave an impression of its thread.

The roll may be presented to the work in either a tangential direction, as illustrated at *C*, or radially, as shown at *D*. A satisfactory thread may be rolled in either way. When the roll

is applied as shown at *C*, it gradually comes into contact with the periphery of the work and completes the thread as it passes across the blank surface in the direction indicated by the arrow. When the roll is presented in this way, the threaded piece should be cut off from the bar of stock before the roll is returned to its starting position, to prevent injury to the finished thread. This is done by simply mounting a cutting-off tool on the cross-slide in such a position that it severs the finished piece after the thread is rolled. The cam operating the cross-slide is arranged to quickly move the roll inward until it is nearly in contact with the surface of the blank; the cross-slide and roll are then given a slow feeding movement usually varying from about 0.002 to 0.004 inch per revolution of the work, while the roll is moving a distance x from the point of contact to the central position. The roll is then moved rapidly past the work in order to bring the cutting-off tool into position.

When the roll is in a radial position, as illustrated at *D*, it is simply forced against one side of the work until a complete thread is formed, the roll and work rotating together the same as two gears in mesh. Some roll-holders, instead of being held rigidly, are carried by a swinging arm which receives its motion from some form of cam. The exact method of applying the roll to the work and of holding it in position may depend, to some extent, upon the relation between the thread-rolling operation and other machining operations.

Diameter of Threading Roll. — The diameter of the threading roll may be about the same as the diameter of the screw thread it is intended to roll, or some multiple of the screw thread diameter. If the thread to be rolled is larger in diameter than, say, $\frac{3}{4}$ inch, a roll may be used which is approximately equal to the diameter of the work, but if the required screw thread is much less than $\frac{3}{4}$ inch in diameter, the roll may be made twice as large, or some multiple of the screw diameter. When the roll and the screw thread are of about the same diameter, they are practically alike so far as the pitch and diameter of the thread are concerned. For instance, the roll for a $\frac{3}{4}$ -inch screw thread might also be $\frac{3}{4}$ inch, minus a slight amount, in order to obtain a better

rolling action, as explained later. If the screw thread to be rolled were $\frac{1}{2}$ inch in diameter, the roll might be two or three times as large.

Whatever the relation between the size of the screw thread and the roll, it is essential to use a roll having threads that mesh with or follow the threads on the work as the two revolve together. This means that the roll thread must have the same pitch as the screw thread and about the same helix angle. Now when the threads on the roll and work are practically duplicates as to diameter, the roll for a $\frac{3}{4}$ -inch single screw thread would also have a single thread, as shown at *A*, Fig. 25. If the roll is twice as large as the screw, it cannot have a single thread, because, for a given pitch, any increase of the roll diameter reduces the angle between the thread and a plane perpendicular to the axis; therefore, if the diameter of the roll is made twice as large as the screw thread, it is necessary to use a roll having a double thread, as illustrated at *B*, instead of a single thread. The pitch of the double thread remains the same, but since the lead equals twice the pitch, the helix angle of the thread is the same as for a single thread of one-half the diameter. If a roll three times the size of the screw thread were used, it would require a triple thread, and so on.

If it is assumed that a roll is used having the same diameter as the thread after rolling, it will rotate at a slower rate than the work at the beginning of the rolling operation, because the roll is larger than the unthreaded screw blank and is driven by the blank. As the roll sinks into the blank, its speed gradually increases until, under ideal conditions, the speed is practically the same as that of the thread being rolled. It has been found in practice that better results are obtained when a roll is used that is slightly smaller in diameter than the diameter of the screw thread to be rolled. For instance, if the work has a $\frac{3}{4}$ -inch U. S. standard thread, a single-threaded roll used for this operation might have a diameter of, say, 0.660 inch instead of 0.750 inch. If a larger roll having a double thread were used, its diameter would equal $2 \times 0.660 = 1.32$ inch instead of 1.50 inch.

The reason for decreasing the diameter of the roll will be more apparent by considering the action of the roll and screw thread when a thread is being formed. As previously mentioned, the roll rotates at a slower speed than the screw blank, especially when the rolling operation begins, because the outside diameter of the roll is in contact with the plain blank which is about as large as the pitch diameter of the screw. As the rolling of the thread progresses, the roll speed might increase until it was practically the same as the work speed, but on

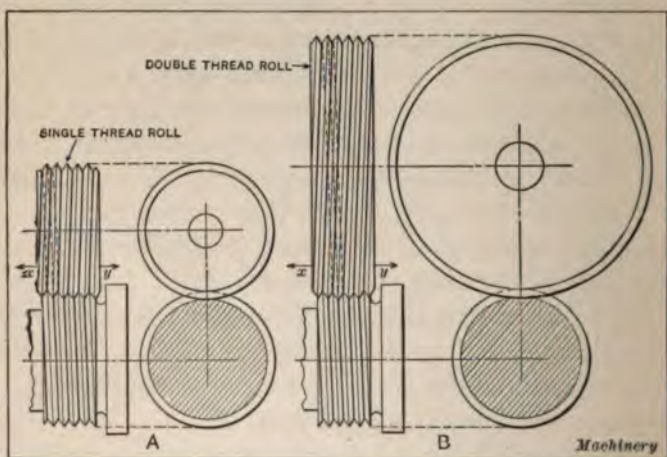

Fig. 25. (A) Threading Roll and Screw Thread of approximately the Same Diameter. (B) Threading Roll nearly Twice as Large in Diameter as Screw Thread

account of frictional resistance between the roll and its holder, the natural tendency is for the roll to lag behind the screw thread. Now any retardation of the roll causes an increase of frictional resistance and the final result may be that the roll speed decreases to such an extent that it no longer meshes with the screw thread properly and, consequently, the thread is marred or spoiled.

The action between the roll and the screw thread will be more apparent by referring to Fig. 25. When the roll lags behind, the more rapidly revolving work, acting as a screw, forces the roll over against the side of the holder, as indicated by arrow

x. The resulting increase of frictional resistance causes the roll to revolve still slower. On the contrary, if the roll is a little smaller in diameter than the work, so that it rotates faster, the roll tends to move in the opposite direction, as indicated by the arrow *y*. If this movement occurs and the roll presses against the side of the holder, thus increasing the frictional resistance, this tends to reduce the speed and cause the roll and work to rotate together properly; consequently, with the roll running a little faster than the screw, any difficulty from side thrust is cared for automatically, because then the driven roll tends to move axially in a direction opposite to that in which the screw thread on the work would naturally force it.

Calculating the Threading Roll Diameter. — The outside diameter of the threading roll may be determined by the following rule: Multiply the depth of a single thread (corresponding to the pitch of the thread to be rolled) by 1.25; subtract the product from the outside diameter of the required thread, and multiply the difference by the number of threads or “starts” on the thread roll. This rule is embodied in the following formula:

$$R = N(S - 1.25 D) \tag{1}$$

in which

- R* = outside diameter of roll;
- N* = number of starts or threads on roll;
- S* = outside diameter of finished screw thread;
- D* = depth of a single thread.

To illustrate the application of the rule and formula, suppose a roll is required for a $\frac{5}{8}$ -inch U. S. standard thread. Then *S* = 0.625 inch, and *D* = 0.059 inch. $0.625 - 1.25 \times 0.059 = 0.5513$ inch, which would represent the diameter of the roll, if it were made with a single thread. Such a roll, however, would be too small and the diameter would probably be doubled, which would make it necessary to use a roll having a double screw thread. In that case, diameter $R = 2 \times (0.625 - 1.25 \times 0.059) = 2 \times 0.5513 = 1.100$ inch, approximately.

The following method of determining the roll diameter has been used successfully by a prominent manufacturer of auto-

matic screw machines. *Rule:* Determine the pitch diameter of the thread to be rolled and deduct from it one-sixth of the double depth of the thread; then use the constant thus obtained as a multiple for determining the pitch diameter of the thread roll. Ordinarily, the roll would be two, three, or four times the diameter of the screw thread and have either a double, triple, or quadruple thread, in order to secure the proper thread helix angle. Expressing the preceding rule as a formula:

$$P = M \left(D - \frac{T}{6} \right), \quad (2)$$

in which

P = pitch diameter of thread roll;

M = multiple selected with reference to approximate diameter of roll desired. (This number also equals the number of threads on the roll.);

D = pitch diameter of screw thread;

T = double depth of thread.

Kind of Thread on Roll. — The thread (or threads) on the roll should be left-hand for rolling a right-hand thread, and *vice versa*, so that the thread on the roll and work will incline in the same direction at the point of contact. The roll should also be wide enough to overlap the section to be threaded, provided the latter is "necked" or turned down at the ends to provide a clearance space, which should be done if possible. The thread on the roll should be sharp on the top for rolling U. S. standard threads as well as V-threads. If the roll thread is made flat, the blunt edge will require too much pressure to force it into the metal and will not produce as smooth a thread. While a roll made in this way will not form a correct U. S. standard thread, the fact that the thread has a sharp bottom, instead of the standard flat form, may be of little importance as compared with the advantages of the rolling process. The bottom of the thread groove on the roll may also be left sharp or it may have a flat, some rolls being made one way and some the other. If the thread groove is sharp in the bottom, the roll is only sunk far enough into the blank to form a thread having a flat top. Some

contend that it is preferable to have a flat at the bottom of the threading roll groove in order to roll down the top of the thread, and thus obtain a smoother edge or surface.

The ends of the roll should be beveled to an angle of about 45 degrees so that the thread or threads will not chip or break out when rolling a thread. Incidentally, the threads on rolls are usually finished by lapping after hardening in order to make them smooth. As the roll is simply driven by frictional contact with the work, it is essential to reduce the frictional resistance of the roll-holder as far as possible. The pin upon which the roll revolves should be only slightly larger than is necessary to reduce the shearing strain when rolling a thread. For instance, a $\frac{1}{2}$ -inch hole in a thread roll 1 inch in diameter might cause considerable trouble, owing to the frictional resistance, whereas, a hole $\frac{3}{8}$ inch in diameter might prevent trouble resulting from lagging or retardation of the roll.

Finishing Threads by Rolling. — The rolling process has been applied to the manufacture of taps for finishing tap threads, although this method has not proved satisfactory for all classes of work. The tap thread is first cut to approximately the required shape and size and then the tap is passed between rollers which compress the metal and give the thread the correct form. The advantage claimed for this finish rolling process is that it increases the density and hardness of the thread, with the result that a rolled tap will resist wear considerably better than a tap which is finished by a cutting tool. Some contend that small taps having rolled threads are five times as durable as those with cut threads. A design of thread-rolling tool that has been used in connection with tap manufacture has three rollers located 120 degrees apart. The annular ridges on these rollers are perpendicular to the axis, and not helical like a thread. The rollers are mounted in the same plane, but the ridges on successive rollers are located one-third the pitch in advance, so that they will engage the thread to be rolled.

CHAPTER XIII

CUTTING AND GRINDING PRECISION SCREW THREADS

MAKING precision screws is one of the most difficult operations connected with the production of fine tools, instruments, or machines for which such screws may be required. The extent of the difficulty depends, of course, largely upon the degree of precision necessary. The production of a screw thread which must be extremely accurate requires great care and the use of the right kind of tools or machines, owing to the helical curvature of the thread and the necessity of maintaining, as far as possible, a true helix as well as a thread of uniform shape and size throughout its length. The most important errors to guard against are those affecting the lead or pitch of the thread. This is due to the fact that any error in the pitch of a screw requires a reduction of pitch diameter equal to nearly twice this error, in order that the screw may operate in a nut the same as a screw which is accurate both as to pitch and diameter.

Periodic and Progressive Errors in Screw Threads.— The errors in a screw thread may either be periodic or progressive. A "drunken" thread is an example of a periodic error as the inaccuracy occurs in every turn of the thread, whereas cumulative inaccuracy in the lead illustrates what is meant by progressive error. Since it is impossible to produce a perfect and absolutely accurate screw thread, the periodic and progressive errors are always combined more or less, and variable local errors are the result. The terms "periodic" and "progressive," however, serve to indicate the kind of error that is most apparent. These errors may be due to a variety of causes, but, as a general rule, a periodic error is developed while cutting a thread either by a slight eccentricity of the lathe spindle or as the result of a lack of uniformity in the lathe gearing. For instance, if there is a slight error in the gear teeth, the uniformity of

movement of the lathe lead-screw will be affected when the defective gear teeth come into mesh, so that an error is transmitted to the screw at regular intervals. An error of this kind is, of course, very slight and it probably could not be detected, except by the methods of testing which are applied to screws for scientific instruments, etc., which require the greatest accuracy attainable. The cause of a progressive error is more difficult to trace and may be due to lost motion in the machine members, lack of straightness of the lathe bed, or an inaccurate lead-screw.

Originating a Precision Screw. — A precision screw may be produced by copying or duplicating another screw of known accuracy, and this is the general method of procedure, but precision screws of the highest grade may need to be corrected by special means after the thread has been cut. It is apparent that at some period in the process of accurate screw thread development, it was necessary to originate a lead-screw that could afterwards be used as a master in producing other screws. While such work is rarely done, a method of originating a screw which has been employed successfully may be of general interest. A wire of uniform diameter is closely wound around an accurate mandrel and is held in place by soldering. This mandrel is then mounted on the spindle of a lathe of the "sliding mandrel" type, which is used in some instrument shops for chasing short threads. A screw thread is formed by applying a multiple thread-cutting tool of the chaser type to the wire. This tool has the teeth very accurately spaced and it is held stationary in a slide-rest. A block of hard wood is also held stationary on a separate support and forms the nut or guide for the screw mandrel, the cutting tool and nut being 180 degrees apart. When the lathe revolves slowly with the cutting tool in contact with the wire, the latter is turned to form a screw thread. The object of using a multiple tool instead of one having a single point is to correct both the periodic and progressive errors.

Compensating for Lead-screw Errors. — Very accurate screws may be cut by using a lathe arranged to compensate, as far as possible, for any errors which may be in the lead-screw. While this method has been used very little, it involves an interesting

principle. The first precision lathe having the type of compensating device to be described was designed along the general lines of an ordinary engine lathe, except that the lead-screw extended through the center of the bed and was directly beneath the carriage, in order to avoid any turning or twisting tendency as the carriage traversed along the bed. On the rear side of the bed, a very accurate scale was mounted. Above this scale there was a microscope held by a bracket attached to the slide-rest. The nut engaging the lead-screw was so arranged that it could turn about the screw and thus increase or retard the movement of the carriage derived from the rotation of the lead-screw sufficiently to compensate for errors at different parts of the lead-screw. In order to obtain this turning movement of the nut, the latter had attached to it a lever which extended up over the front side of the lathe body and carried at its outer end a roller. This roller was in engagement with the edge of a former plate or templet of such a shape that the upward or downward movement of the roller and lever automatically caused the nut to increase or retard the carriage movement as required by the lead-screw errors.

In constructing this error-compensating attachment, the contour or shape of the templet was determined in the following manner: The carriage was first adjusted until the cross-hair of the microscope coincided with one of the lines on the scale attached to the lathe bed. The lathe was then turned whatever number of revolutions would be required to advance the carriage exactly one inch, assuming that the lead-screw were perfect. The relative positions of the cross-hair of the microscope and the inch division on the scale were then noted, and if they did not coincide, the lever attached to the nut was raised or lowered just enough to compensate for the error. In this way, one point along the edge of the templet was located, and by repeatedly adjusting the carriage one inch at a time and noting the errors, a series of points were obtained which indicated the curvature of the templet.

The first lathe equipped with this type of compensating attachment was used exclusively for cutting precision screw

threads of the same pitch as the lead-screw; therefore, the gears connecting the headstock spindle and lead-screw were of the same size. The templet previously referred to was laid out to compensate for errors both in the lead-screw and gears, and care was taken to keep these gears in the same relative positions, so that any irregularity of the tooth spacing would always occur in the same order.

A precision lathe used by the National Physical Laboratory of Great Britain has the same general type of compensating attachment described in the foregoing. This lathe is so designed that the lead-screw and whatever screw is being cut are in line with each other. The machine is very rigidly constructed and there are separate carriages for the lead-screw nut and cutting tool. These carriages are connected by heavy rods. This machine is simply used for correcting the errors in screws which have been finished nearly to size in another lathe. Screws having errors of less than 0.0001 inch per foot of length have been finished in a precision lathe of this kind.

Finishing Threads by Grinding. — Screw threads are sometimes ground in order to correct slight distortions due to hardening. This method is applied in the manufacture of thread gages of the plug form. As it is necessary to harden these gages to prevent excessive wear, there is liable to be distortion; then grinding is necessary in order to eliminate whatever errors may result from the heat-treatment. The special attachment shown in Fig. 1 is used for thread gage grinding by the Blair Tool & Machine Works, Inc., 515 Greenwich St., New York City. This attachment is applied to a bench lathe. The construction is such that the grinding wheel *A* may be adjusted to locate the working side in alignment with the thread being ground. This angular adjustment is obtained by turning the knurled handle *B* which revolves a small worm-wheel that engages a sector attached to the bracket carrying the wheel-spindle. The horizontal axis about which this bracket swings coincides with the axis of the thread gage, so that the edge of the wheel always makes contact with the gage at a point intersecting a horizontal

plane passing through the gage axis, for any angular adjustment of the wheel-spindle.

The wheel is dressed to the required angle by a diamond mounted at the end of holder *M*. This holder passes through block *C* and is normally held away from contact with the wheel by spring *D*. In order to true one side of the wheel, the holder is simply pushed inward, thus traversing the diamond across the grinding surface of the wheel. The holder is pivoted at *E* and its angular position relative to the axis of the wheel is controlled

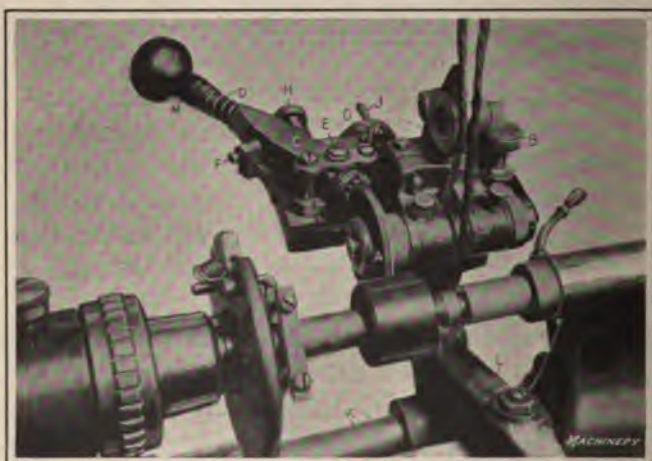

Fig. 1. Grinding Thread Gage by Means of Thread-grinding Attachment applied to a Bench Lathe

by a stop *F* on one side and a stop *G* which is used when the holder is swung around for truing the opposite side of the wheel. These stops are adjusted very accurately by using a sine bar. This adjustment, of course, is not changed except when the fixture is used for grinding a different angle of thread. The diamond holder is carried by a slide which may be adjusted in a direction at right angles to the axis of the wheel-spindle by turning the knurled screw *H*. This adjustment is required for moving the diamond tool inward as the wheel diameter is reduced on account of wear. The fixture is also mounted upon a slide so that the wheel can be adjusted in or out in accordance with the

diameter of the gage to be ground. This adjustment is effected by the handwheel *J* with graduations representing 0.001 inch reduction on the diameter.

The entire fixture is supported by a bracket carried by shaft *K* extending along the rear of the bed and having an arm or lever *L* which projects across the bed to the front of the machine. The shaft *K* has attached to it an arm at the rear of the headstock, which carries a follower nut that engages with a short lead-screw for traversing the grinding wheel along the

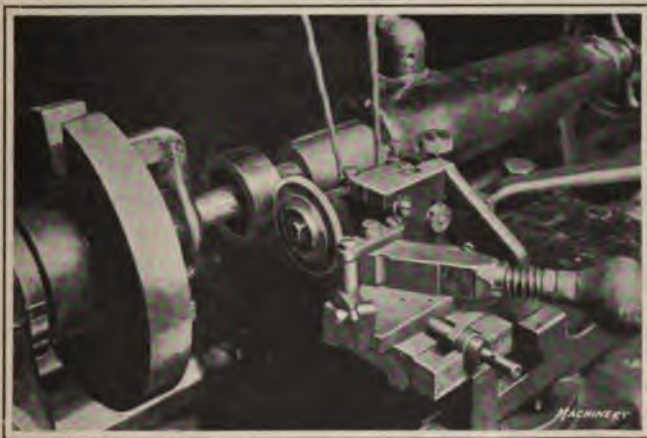

Fig. 2. Thread-grinding Attachment mounted on Tool-slide of Engine Lathe

thread being ground. This lead-screw is geared to the main spindle of the bench lathe and the follower is engaged or disengaged with it by simply lowering or lifting lever *L* and thus turning shaft *K* in its bearings. This part of the attachment is designed along the same general lines as the well-known chasing attachment of the Fox type of lathe. The diameter of the thread is tested while grinding it by the three-wire method. The angle of the thread is also tested by using large and small wires for obtaining measurements at two different points along the slope of the thread. Clearance is provided at the root of the thread so that it is not necessary to dress the edge of the wheel for grinding a flat at the root of standard width. In

order to secure accurate work with this attachment, it is necessary, of course, to use an accurate lead-screw.

Thread-grinding Attachments for Lathe. — Thread grinding is often done on an engine lathe by means of a special attachment. A lathe used for this work should have an accurate lead-screw. Fig. 2 shows the same general type of thread-grinding attachment illustrated in Fig. 1 applied to an engine lathe. The attachment is mounted upon the compound rest which is set parallel to the lathe centers for adjusting the wheel in an axial direction.

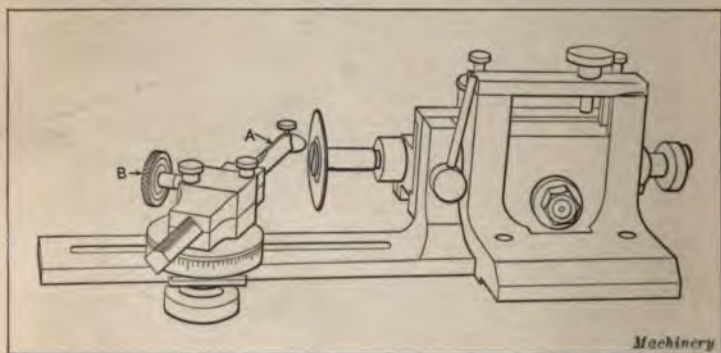

Fig. 3. Another Design of Thread-grinding Attachment for the Lathe

Another form of lathe thread-grinding attachment for correcting the distortion in hardened thread gages or for similar work is illustrated in Fig. 3. This grinder is clamped to the tool-slide after removing the toolpost. The grinding wheel is trued to whatever angle may be required by a special diamond truing device. The diamond holder *A* is provided with rack teeth which mesh with a pinion operated by the knurled hand-wheel *B*, which serves to traverse the diamond across the surface of the wheel. All lost motion in the diamond holder is eliminated by means of a spring which exerts pressure upon the rack. The base beneath the diamond holder is graduated for setting the diamond tool at any angle. The wheel-spindle is so mounted that the grinding side of the wheel can be aligned with the helix angle of the thread. The point of contact between

the edge of the grinding wheel and work remains in a plane intersecting the lathe centers, regardless of the angular adjustment, assuming that the attachment is set to the correct height. The driving shaft is independent of the main bearing shaft and a special fiber core is provided at the end of the driving stud to eliminate end play and absorb any vibration that might otherwise be transmitted to the wheel. This thread grinder is made by the International Equipment Co., 1553 S. 58th St., Philadelphia, Pa.



Fig. 4. Grinding One Side of Thread-cutting Tool on Surface Grinder

Holder for Grinding Thread-cutting Tools.— A thread-cutting tool should be so ground that the included angle between the cutting edges or in the plane of the top face is equal to the angle of the thread to be cut. A simple method of insuring accurate grinding is illustrated in Figs. 4 and 5. The cutting point or tool (which is held in a tool-holder while in use) is fastened in a block which is mounted on the magnetic chuck of a surface grinder. Fig. 4 illustrates the position of this block for grinding one side of the tool, and Fig. 5 illustrates how the top surface or face is ground. In one case, the side of the block is placed against the plate, and in the other, the end surface.

This block holds the tool in such a position that it is given a clearance angle of 15 degrees and at the same time is ground to the standard included angle of 60 degrees in the plane of the cutting face. The diagram, Fig. 6, illustrates more clearly the relation between the sides of the block and the tool. The sides *A* and *B* are used for grinding U. S. standard thread tools. The sides *C* and *D* may be used when grinding thread tools of some other angle, assuming that these sides are of the required inclination. When using sides *C* and *D*, the tool to be ground is inserted in end *E* of the tool slot.

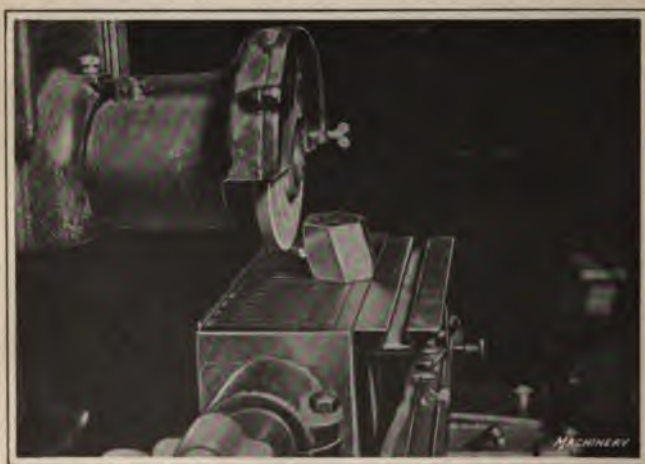

Fig. 5. Grinding Top Face of Tool on Surface Grinder

In making a block of this kind, it is necessary to modify the angles between the sides and the center line of the tool-holding slot, so that the cutting edge of the tool will be ground to the correct included angle in the plane $y-y$ of the top face. This means that the angle of the tool in a plane $x-x$ at right angles to the front edge will be somewhat greater than 60 degrees; consequently, the angle α between the sides which rest against the chuck and the center line of the tool must exceed 30 degrees.

The tangent of angle $\alpha = \frac{\tan \text{one-half of thread angle}}{\cos \text{front clearance angle of tool}}$. Assuming that the clearance angle is 15 degrees and the thread

angle 60 degrees, $\tan \alpha = \frac{\tan 30 \text{ degrees}}{\cos 15 \text{ degrees}} = 0.5977$, and the angle α , 30 degrees 52 minutes; therefore, the tool is ground to an included angle of 61 degrees 44 minutes in a plane at right angles to the front edge, in order to obtain an angle of 60 degrees in the plane of the top face.

The end surfaces of the block are parallel with the tool-holding slot which is inclined to correspond to the front clearance

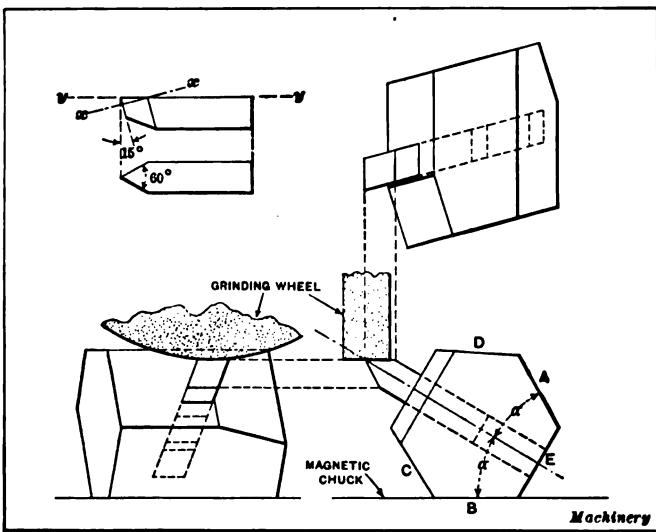

Fig. 6. Showing Inclination of Sides of Holder Relative to Thread Tool

angle of 15 degrees. Just above the tool there is a vertical surface which is simply to provide clearance for the wheel when grinding the top face. This block is formed of two sections which are held together by screws and dowel-pins. The joint between the two sections intersects the tool-holding slot and is parallel with the end surfaces.

Making Screws for Scientific Instruments. — The most accurate screw threads that it is possible to produce are those required for scientific instruments and especially for the apparatus used in connection with astronomical observations. Even a

very slight inaccuracy in the screw of one of these instruments may be multiplied a great many times, owing to the extreme distances involved, as, for example, when a micrometer screw is used as a basis for determining the distance between two stars; consequently, some of the most accurate screws in existence are used in connection with the instruments referred to.

The method outlined in the following of producing precision screws of the accuracy required for scientific instruments represents the practice of William Gaertner & Co., Chicago, Ill. The screw thread is first cut as accurate as possible and then

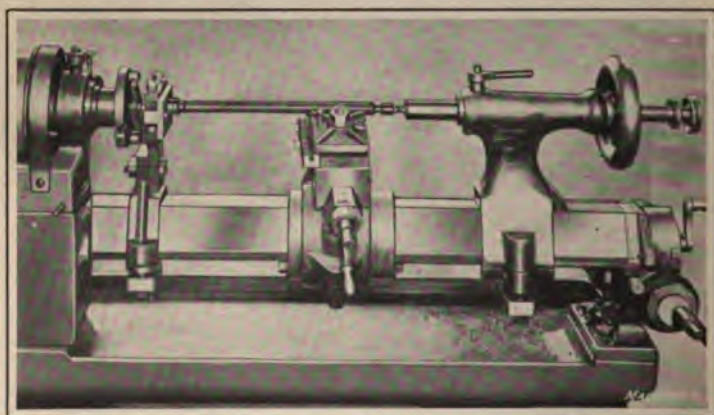

Fig. 7. Lathe used for Cutting Precision Screws for Scientific Instruments

very slight inaccuracies are corrected by a second re-cutting operation. The lathe first used is shown in Fig. 7. The most important features of this lathe are an exceedingly accurate lead-screw and accurate gearing. In making precision screws, it is very essential to provide bearing surfaces on the screw which are concentric with the screw thread. The lathe used for this work is so arranged that the screw is held in position by the same bearing surfaces that are used afterwards when the screw is assembled in whatever apparatus it is intended for. This method of mounting insures cutting a thread which is concentric with the bearings previously turned at the ends of the screw blank;

moreover, slight inaccuracies are prevented that might be introduced in the screw as the result of belt pull or because of imperfections in the lathe spindle bearings. A dog is clamped to one end of the screw to provide means of rotating it.

The steel used for these screws must be of fine grain and homogeneous. After the thread is cut on the lathe referred to, the screw is carefully examined for defects that may have been exposed by the screw-cutting operation. The screw is then put aside and allowed to season for several months so that it will

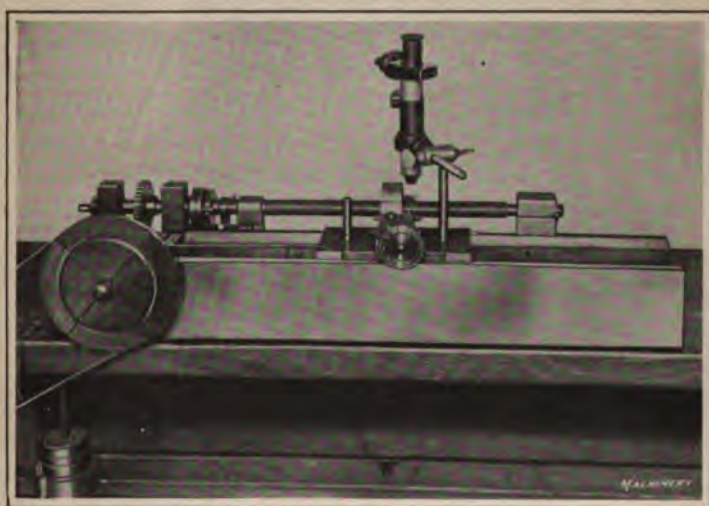

Fig. 8. Re-cutting Machine for Precision Screws so arranged that Error in Screw controls Position of Tool and thus eliminates Itself

take the full "set" developed by the removal of metal when cutting the thread.

Re-cutting Operation on Precision Screws. — All precision screws, after the seasoning period previously mentioned, are re-cut in a special type of machine illustrated in Fig. 8. This machine is used to eliminate, as far as possible, the periodic error which is the kind of error that increases from zero to maximum and then decreases to zero in one turn of the screw. A graphical representation of this error would be in the form of a wavy line or curve with the wave centers 360 degrees apart.

The re-cutting machine is so arranged that the error controls the position of the cutting tool and thus eliminates itself. The screw thread is engaged by the V-shaped end of a rod which serves as a nut. This rod is carried by a U-shaped yoke that is attached to the tool-slide and extends over the screw, as shown more clearly by the end view of the machine, Fig. 9. This V-shaped rod or nut may be placed 180, 90, or 45 degrees from the tool.

The first cut for correcting the error is taken with the guide nut set at 180 degrees from the cutting tool. When this nut

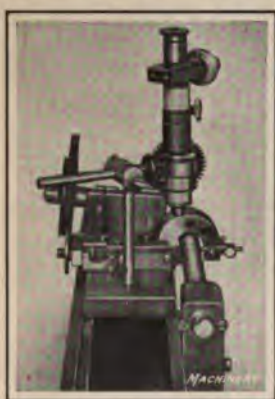

Fig. 9. End View of Re-cutting Machine for Precision Screws

engages the screw point at a point of maximum error, the tool is opposite the point where there is little or no error; conversely, when the tool is at the point of maximum error, the nut is opposite the errorless position. When the re-cutting machine is in operation, the nut, as it encounters the inaccurate side, moves the tool-slide along the bed and advances the tool toward the screw an amount depending upon the error. A counterweight connected to the tool-slide by a cord relieves the screw thread and nut of much of the strain incident to moving the tool-

slide along the machine bed. As a result of this movement of the tool-slide, the cut from the point of zero error increases up to the maximum as the screw makes one-half turn and then decreases. Of course, the amount of metal removed during this re-cutting operation is extremely small. In fact, it is necessary to use a microscope to observe the very light cut which gradually increases and then diminishes and leaves only a fine dust of metal on the end of the tool. One of these cuts is taken with the guide nut set at 180 degrees from the tool, which reduces the error to one-half of what it was previously. The nut is then placed in the 90-degree position and a second cut is taken which again reduces the error one-half. The final cut is then

taken with the guide nut set at 45 degrees from the tool, which again divides the error so that it is only $12\frac{1}{2}$ per cent that which originally existed.

Since the original screw, prior to re-cutting, is very accurate if judged by ordinary standards, it will be apparent that the error in the finished screw is exceedingly small. The degree of error is indicated by the fact that these screws are guaranteed to be accurate in lead within 0.001 millimeter, or approximately 0.00004 inch, and much greater accuracy has been secured. This degree of precision is attained by using the re-cutting machine referred to, in which the periodic error is utilized to adjust the tool for eliminating the error. The application of this principle, however, would prove inadequate if the machine had not been carefully constructed and lost motion eliminated in setting up the work. In constructing the machine, great care was taken to secure very accurately fitting bearings and slides and straight guides. The screw to be re-cut must also be exactly parallel to the guides and be so mounted as to eliminate chatter or vibration. The screw is driven by a special form of coupling instead of a dog, which compensates for any lack of alignment and relieves a delicate screw of strains that it might be subjected to if an ordinary dog were used.

Testing Precision Screws. — In testing the screws intended for scientific instruments, the common practice in the laboratory is to apply the test to the completed instruments of which the screw forms a part. A microscope is used having a fine wire or "spider thread" in the eye-piece and an accurately divided scale. The microscope may be carried on the slide which is moved by the screw or it may be held stationary on the frame of the apparatus and the scale placed on the slide. If the microscope is movable, the scale is carefully adjusted so as to be parallel with the axis of the screw. Suppose the pitch of the screw is one millimeter; the scale will then be divided into spaces of 0.1 millimeter. The microscope is focused on the scale and adjusted so that the spider thread in the eye-piece will bisect a scale mark. If the screw-head has a graduated dial with 100 divisions and the microscope is moved to the

next line on the scale, the reading on the dial should be ten divisions.

In moving the microscope from line to line on the scale, and observing the readings on the graduated dial, the screw is directly compared with the scale. Any discrepancy from the required readings on the dial for each corresponding movement of the screw indicates an error; but what about the error in the scale, and the errors that may be made in setting with the microscope? These are two uncertain factors to be considered. The scale may be tested at the Bureau of Standards,

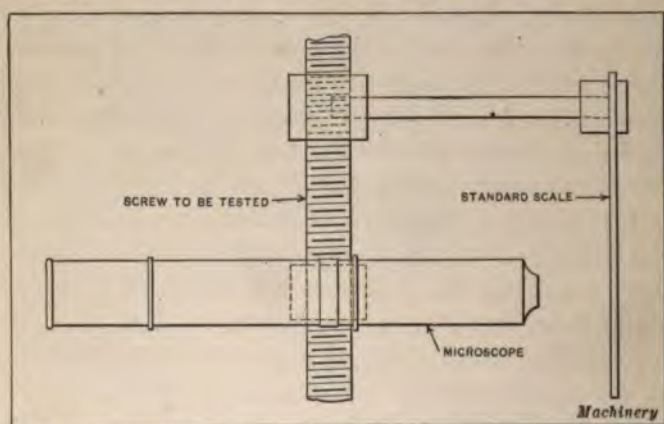

Fig. 10. Method of testing Accuracy of Precision Screw with Microscope and Standard Scale

so that the value of every scale division is known, and the error of setting may be eliminated by taking the mean of a number of readings. Testing a screw by this method, however, is, at best, a slow and tedious proceeding and requires great patience and a trained observer, so that it would not be suitable for use in a manufacturing shop.

Another and quicker method that has been used is to mount the microscope and scale on two separate carriages, which are moved by the screw, as shown diagrammatically in Fig. 10. The microscope cross-hair is adjusted to a scale mark, and if the screw is then turned, both the microscope and scale should advance the same amount if the screw is free of errors, and the

scale mark should remain in the same position in the field of the microscope. Any shifting of the scale mark indicates an error in the screw, but it will only show the difference in pitch of the screw at the two places on which the nuts engage.

The most accurate and reliable method of testing the errors of a screw, or of measuring any small unit of length, is based on the application of interference of light waves. The instrument used for testing by this method is known as an "interferometer," and it is the means of obtaining the most accurate results in length measurements. In the shops of William Gaertner & Co., an instrument is used which represents an application of the interferometer principle. This instrument (described in *MACHINERY*, June, 1917, page 854) does not indicate the actual amount of error existing at each point on a screw thread, but it does afford a rapid method of determining whether the maximum error exceeds that which is allowable. As this is all the instrument maker is interested in, the interferometer method is much quicker and less expensive than testing each screw by the tedious micrometer-microscope method to which reference has been made.

INDEX

- A**ccurate screws for scientific instruments, 331
Acme thread, 10
Acme thread tool, testing width of end, 29
Adjustable chaser type of die, 77
Adjustable tap design, examples of, 137
Angle diameter of screw, 5
Angular method of feeding thread tool, 17
Attachments, chasing, applied to tapering work, 58
for changing the pitch, 47
for cutting screws of large lead, 44
for cutting threads on drilling machine, 68
for lathe, thread-grinding, 328
for reversing tap rotation, 182
quick-threading, for engine lathe, 49
thread-chasing, 54
thread-cutting, 44
thread milling, for engine lathes, 276
Automatic dies, application, 78
types of, 80
Automatic feeding mechanism of thread-rolling machine, 291
Automatic lathe, internal thread cutting on, 38
Automatic nut-tapping machine, bent-tap type, 207
Automatic screw machine, thread rolling in, 315
Automatic threading lathe, 35
of taper and relieving type, 39
Automatic threading machine, vertical magazine type, 226
Backing-out attachment of thread milling machine, 249
Blank diameters for thread rolling, 283
Blanks for machine screws having rolled threads, 311
Blank starters, of thread-rolling machine, location and shape, 301
of thread-rolling machine, timing, 289
Bolt cutter or single-spindle threading machine, 214
Boring mill, vertical, thread cutting on, 69
Briggs standard pipe thread, 12
British Association standard thread, 10
British standard thread, 10
Button die, 74
Buttress thread, 13
Cadillac screw thread, 13
Carbon in steel, amount of, for screw stock, 113
Chamfer, on end of tap, 155
or chaser throat, angle of, 121
Change-gears, for metric pitches, 42
for screw-cutting lathe, 40
Chasers, die, grinding throat of, 124
die, rake angles, 128
for thread-cutting dies, 118
hobbed, 118
maintaining rake angle when grinding, 129
milled, 119
milled, tangential type, 120
threading die, steel for, 134
use of, in lathe, 30
Chaser throat, or chamfer, angle of, 121
Chaser throat relief, effect of, on action of die, 123
Chasing attachment, applied to tapering work, 58
for cutting left-hand threads, 57
Chasing dial, principle of operation, 19
used for multiple thread cutting, 23

- Chucks, frictional tapping, 170
 friction-reducing tapping, 180
 quick-action, sliding-collar, 178
- Clearance or relief for tap cutting edges, 157
- Collapsing taps, advantages, 140
 Geometric, 143
 M. E. C., 146
 Murchey, 145
 "Namco," 141
 resetting, 147
 Victor, 144
- Collet holder for spring-screw die, 75
- Collet or socket type of tap chuck, 179
- Combination die, Murchey, 101
- Combination tap and die, 150
- Combination tapping and boring tool, 151
- Compensating for lead-screw errors, 323
- Compound gearing for thread cutting, 41
- Compound rest used for multiple thread cutting, 21
- "Con-eccentric" relief, 158
- Core diameter of screw, 6
- Crest of thread, 6
- Cutter, multiple, used for milling threads, 229
 of staggered tooth type for thread milling, 249
 single, used for milling threads, 227
- Cutter rotation, direction of, for thread milling, 231
- Cutting speeds for threading dies, 114
- D**efinitions of screw threads, 5
- Diameter, effect of, on method of cutting thread, 234
 of blanks for thread rolling, 283
 of circular threading roll, 316
 of hole before tapping, 159
 of screw threads formed by rolling, 307
- Die and tap, combination, 150
- Die- and tap-holders, 165
- Die chasers, grinding throat of, 124
 rake angles, 128
 threading, steel for, 134
- Die-cut screw threads, causes of lead errors, 102
- Die-feeding movement, positive control, 106
- Die-holder, collet type, for spring-screw die, 75
 for acorn die, 75
 releasing and non-releasing, 166
- Dies, combination, Murchey, 101
 effect of chaser throat relief on action, 123
 effect of diameter adjustment on lead, 104
 flat, used for rolling threads, 280
 for cutting square threads, 113
 for cutting taper threads, 108
 maximum pitch of threads cut with, 107
 method of making flat thread-rolling, 312
 non-opening, removal of, from work, 78
 non-opening, types of, 73
 self-opening, types of, 80
 taper-threading self-opening, 109
 thread-cutting, and their application, 71
 thread-cutting, chasers, 118
 threading, cutting speeds, 114
- Disk, revolving steel, for forming threads, 34
- Drilling machine attachment, for cutting threads, 68
- Drilling machines, tapping mechanism, 187
- Drills, tap, diameter of, 159
- E**ffective diameter of screw, 5
- Ejector of thread-rolling machine, 290
- Engine lathe, quick-threading attachment, 49
 thread milling attachments, 276
- Errors, in lead in die-cut screw threads, causes, 102
 in lead-screws, compensating, 323
 in tapped holes, causes, 135
 lead and diameter, in tapped holes, 161

- Errors, periodic and progressive, in screw threads, 322
- F**eeding mechanism, automatic, of thread-rolling machine, 291
- Feeds and speeds for thread milling, 243
- Fixtures for thread milling, hand-operated, 274
- work-holding, for tapping, 211
- Floating movement for die-holders, 165
- Flutes, tap, forms of, 152
- Forms of screw threads, 6
- Fox thread-chasing attachment, 54
- French and international standard thread, 12
- Frictional tapping chuck, 170
- Friction-reducing tapping chuck, 180
- G**arvin tapping machine, 190, 195
- Gearing, compound, for thread cutting, 41
- Gears, translating, for metric pitches, 43
- Grinding accurate screw threads, 325
- Grinding and cutting precision screw threads, 322
- Grinding attachments, thread, for lathe, 328
- H**arvey grip thread, 12
- Heavy-duty tapping machines, 197
- Hobbed chasers, 118
- Hobbing method of thread milling, 276
- Holder for grinding thread-cutting tools, 329
- I**ndexing for multiple thread cutting, 21
- Indicator, thread, principle of, 19
- used for multiple thread cutting, 23
- Internal thread cutting, on automatic lathe, 38
- operations, 27
- Internal thread milling machine of single-cutter type, 255
- L**athe, adjustment of, for taper thread cutting, 26
- automatic, internal thread cutting on, 38
- Lathe, automatic threading, 35
- automatic threading, controlling mechanism, 37
- automatic threading, cutting tools, 36
- automatic threading, taper and relieving type, 39
- engine, quick-threading attachment, 49
- screw-cutting, change-gears, 40
- thread cutting in, 14
- Lathe attachments, thread-grinding, 328
- Lead and diameter errors in tapped holes, 161
- Lead errors in die-cut screw threads, causes, 102
- Lead of screw thread, 5
- Lead-screw errors, compensating, 323
- Lead-screws, direct-acting, 52
- for coarse pitches, 45
- for threading machines, 218
- Left-hand threads cut with chasing attachment, 57
- Löwenherz thread, 13
- M**achine screw blanks for thread rolling, 311
- Maximum pitch of thread cut with dies, 107
- Metric pitches, change-gears for, 42
- translating gears for, 43
- Milled chasers, 119
- tangential type, 120
- Milling machines, standard, thread milling on, 272
- Milling screw threads, 227
- with multiple cutter, 229
- with single cutter, 227
- Monitor lathe thread-chasing attachment, 54
- Multiple-cutter thread milling method, application of, 236
- Multiple screw threads, methods of cutting, 20
- Multiple-spindle semi-automatic tapping machine, 202
- Multiple-spindle tapping machines, 200

- Multiple thread cutting, by using indicator, 23
indexing, 21
- Multiple threads, 6
milling, 232
- Multiple tool for cutting multiple threads, 24
- N**on-collapsing taps, 136
removal of, from hole, 139
- Non-opening dies, removal of, from work, 78
types of, 73
- Non-releasing and releasing die-holders, 166
- Non-releasing and releasing tap-holders, 172
- Nut-tapping machines, 204
semi-automatic, 205
- O**ldham coupling type of tap-holder, 181
- Originating a precision screw, 323
- Oscillating tapping attachment, 183
- P**eriodic and progressive errors in screw threads, 322
- Pipe thread, Briggs standard, 12
chasers for cutting smooth, 131
- Pitch, attachments for changing, 47
coarse, lead-screw for, 45
effect of, on method of cutting thread, 234
obtaining slight variations, 46
of screw thread, 5
of thread cut with dies, maximum, 107
- Pitch diameter of screw, 5
- Positive control of die-feeding movement, 106
- Precision screws, for scientific instruments, 331
originating, 323
re-cutting operation, 333
testing, 335
- Precision screw threads, cutting and grinding, 322
- Progressive and periodic errors in screw threads, 322
- Q**uick-action chuck, sliding-collar type, 178
- Quick-change tap-holders, 174
- Quick-threading attachment for engine lathe, 49
- R**adial type tapping machine, 198
- Rake angles, for die chasers, 128
of chaser, maintaining, when grinding, 129
- Rake of tap cutting edges, 154
- Reaming action with tap, cause of, 157
- Releasing and non-releasing die-holders, 166
- Releasing and non-releasing tap-holders, 172
- Relief, "con-eccentric," 158
of chaser throat, effect of, on action of die, 123
or clearance for tap cutting edges, 157
- Reversing and variable-speed attachment, 185
- Reversing tap chucks, 182
- Rolled thread, regulating length, 299
- Rolling screw threads, 279
advantages of process, 309
determining blank diameters for, 283
diameter which can be rolled, 307
flat dies used for, 280
in automatic screw machine, 315
rate of production, 308
use of process for finishing, 321
- Root diameter of screw, 6
- Root of thread, 6
- Rotary thread-rolling machine, 305
- S.** A. E. standard screw thread, 13
- Scientific instruments, screws for, 331
- Screw-cutting lathe, change-gears, 40
- Screw machine used for thread rolling, 315
- Screws, angle diameter, 5
core diameter, 6
effective diameter, 5
for scientific instruments, 331
of large lead, attachments for cutting, 44

- Screws, pitch diameter, 5
 precision, originating, 323
 precision, re-cutting operation, 333
 precision, testing, 335
 root diameter, 6
- Screw stock, amount of carbon in steel used for, 113
- Screw threads, Acme, 10
 Acme, testing width of tool point, 29
 Briggs standard pipe, 12
 British Association standard, 10
 British standard, 10
 buttress, 13
 Cadillac, 13
 cutting and grinding precision, 322
 definitions, 5
 different forms, 6
 formed by rolling, sizes of, 307
 French and international standard, 12
 Harvey grip, 12
 lead of, 5
 Löwenherz, 13
 methods of forming, 1
 multiple, 6
 multiple, methods of cutting, 20
 periodic and progressive errors, 322
 pitch of, 5
 S. A. E. standard, 13
 sharp V-, 9
 square, 11
 square, width of tool point for cutting, 30
 time required for rolling, 308
 trapezoidal, 13
 U. S. standard, 8
 U. S. standard, testing width of tool point, 29
 Whitworth standard, 10
 Whitworth, tools for cutting, 32
 worm, 11
- Selection of thread-forming method, 4
- Self-opening die-head, Errington, 99
 H & G, 97
- Self-opening dies, advantages of, 78
 application, 78
 Geometric, 81
 Hartness, 89
 "Namco," 86
- Self-opening dies, types of, 80
 Wells, 91
- Self-opening or rotary die-head, Landis type, 95
- Self-opening taper-threading dies, 109
- Sellers thread, 8
- Semi-automatic multiple-spindle tapping machine, 202
- Semi-automatic nut-tapping machine, 205
- Side-feed type of thread-rolling machine, 302
- Single-lever control for threading machines, 220
- Sliding-collar type of quick-action chuck, 178
- Slope of thread, 6
- Socket or collet type of tap chuck, 179
- Speeds, and feeds for thread milling, 243
 cutting, for threading dies, 114
 for tapping, 164
- Spring-screw die, 74
- Square threads, 11
 cutter interference when milling, 240
 cut with dies, 113
 dies used for rolling, 314
 tapping, 160
 width of tool point for cutting, 30
- Starters, for thread-rolling machines, location and shape, 301
 of thread-rolling machine, timing, 289
- Station-type tapping machine, 209
- Steel, for screw stock, amount of carbon contained, 113
 for threading die chasers, 134
- Stock for thread rolling, 312
- Stops on thread-rolling machines for regulating thread length, 299
- Stud-threading machines, 224
- T**angential type milled chasers, 120
- Tap and die, combination, 150
- Tap- and die-holders, 165
- Tap cutting edges, clearance or relief, 157
 rake of, 154
- Taper and relieving type of automatic threading lathe, 39

- Taper thread cutting, adjustment of lathe, 26
- Taper-threading dies, self-opening, 109
- Taper threads, chasing, 58
cut with dies, 108
milling, 241
position of tool used for cutting, 25
- Tap flutes or cutting faces, forms of, 152
- Tap-holders, of Oldham coupling type, 181
of quick-change type, 174
releasing and non-releasing, 172
- Tapped holes, causes of errors, 135
lead and diameter errors in, 161
- Tapping and boring tool, combination, 151
- Tapping, cause of reaming action, 157
diameter of hole previous to, 159
- Tapping chucks, frictional, 170
friction-reducing, 180
- Tapping fixtures, work-holding, 211
- Tapping machines, 187
for nuts, 204
multiple-spindle, 200
semi-automatic multiple-spindle, 202
station type, 209
- Tapping mechanism of drilling machines, 187
- Tapping speeds, 164
- Tapping square threads, 160
- Tap rotation, attachments for reversing, 182
- Taps, adjustable, examples, 137
chamfer on end, 155
classes of, 135
collapsing, advantages, 140
collapsing, Geometric, 143
collapsing, M. E. C., 146
collapsing, Murchey, 145
collapsing, "Namco," 141
collapsing, resetting, 147
collapsing, Victor, 144
conditions governing use of, 135
methods of holding and driving, 169
non-collapsing, 136
- Tap-threading machine, upright, 223
- Testing precision screws, 335
- Thread chasers used in lathe, 30
- Thread-chasing attachment, 54
method of using, 56
of Acme flat turret lathe, 67
of Hartness flat turret lathe, 65
- Thread-cutting attachments, 44
- Thread cutting, by means of compound gearing, 41
by means of revolving tool, 33
effect of diameter, pitch, and torsional strain on method, 234
in lathe, conditions governing, 14
internal, on automatic lathe, 38
on drilling machine, 68
on vertical boring mill, 69
- Thread-cutting dies, and their general application, 71
chasers, 118
- Thread-cutting operations, internal, 27
- Thread-cutting tools, holder for grinding, 329
single-point, methods of gaging, 27
- Thread-forming method, selection, 4
- Thread-forming processes, 1
- Thread-grinding attachments for lathe, 328
- Thread indicator, principle of, 19
- Threading dies, cutting speeds, 114
- Threading lathe, automatic, 25
automatic, taper and relieving type, 39
- Threading machines, having speed-changing mechanism, 216
lead-screws, 218
single-lever control, 220
single-spindle, or bolt cutter, 214
standard and special, 214
vertical-spindle, 222
with gravity feed, 219
- Thread milling, 227
hobbing method, 276
on standard milling machines, 272
speeds and feeds, 243
with multiple cutter, 229
with single cutter, 227
- Thread milling attachments for engine lathes, 276
- Thread milling fixtures, hand-operated, 274

- Thread milling machines, 246**
 advantages of, 235
 classes of work used for, 232
 internal, of single-cutter type, 255
 Lees-Bradner, 250, 261
 Moline, 252
 Pratt & Whitney, 247
 Reed-Prentice, 269
 Smalley-General, 266
 Taft-Peirce, 257
 Thomson, 264
 Waltham, 254
- Thread milling method, multiple-cutter.**
 application of, 236
- Thread rolling, 279**
 between flat dies, 280
 determining blank diameters for, 283
 diameter of circular roll, 316
 in screw machine, 315
 positions of flat dies to work, 282
- Thread-rolling dies, method of making flat type, 312**
- Thread-rolling machine, automatic feeding mechanism, 291**
 ejector, 290
 rated capacities of, 307
 reciprocating type, 286
 regulating length of rolled thread, 299
 rotary design, 305
 side-feed type, 302
 vertical design, 303
 with feeding mechanism for headless blanks, 297
- Thread-rolling process, advantages and range, 309**
- Thread rolling stock, 312**
- Threads, cut with dies, maximum pitch, 107**
 finished by grinding, 325
 finished by rolling, 321
 formed by revolving steel disk, 34
 milled close to a shoulder, 238
- Threads, multiple, milling, 232**
 on pipe, chasers for smooth, 131
 rolled, regulating length, 299
 square, cut with dies, 113
 square, tapping, 160
 taper, cut with dies, 108
- Thread tool, adjusted by compound rest for multiple threads, 21**
 adjusted by shifting carriage for multiple threads, 22
 for cutting Whitworth threads, 32
 methods of feeding inward, 17
 multiple, 24
 position of, for taper threads, 25
 return of, for successive cuts, 18
 single-point, position of, 15
- Throat, chaser, effect of relief, 123**
 chaser, or chamfer, angle of, 121
 die-chaser, that is ineffective, 123
 of die chaser, grinding, 124
- Time required for rolling screw threads, 308**
- Tool point, width of, for cutting square threads, 30**
- Torsional strain, effect of, on method of cutting threads, 234**
- Translating gears for metric pitches, 43**
- Trapezoidal thread, 13**
- Turret lathe, Acme flat, thread-chasing attachment, 67**
 Gisholt, thread-cutting mechanism, 61
 Hartness flat, thread-chasing attachment, 65
- United States standard thread, 8**
- United States standard thread tool, testing width of end, 29**
- Upright tap-threading machine, 223**
- Variable-speed and reversing attachment, 185**
- Vertical boring mill, thread cutting on, 69**
- Vertical-spindle tapping machines, 195**
- Vertical-spindle threading machines, 222**
- Vertical thread-rolling machine, 303**
- V-thread, 9**
- Whitworth standard thread, 10**
- Whitworth threads, tools for cutting, 32**
- Worm milling machine, Bilton, 270**
- Worm thread, 11 ✓**





